



**Queensland  
Government**

Department of Regional Development,  
Manufacturing and Water



# Queensland interim water meter standard for non-urban metering

**Version 3.02 5 September 2022**

[rdmw.qld.gov.au](http://rdmw.qld.gov.au)

This publication has been compiled by Water Management, Divisional Support, Department of Regional Development, Manufacturing and Water.

© State of Queensland, 2022

The Queensland Government supports and encourages the dissemination and exchange of its information. The copyright in this publication is licensed under a Creative Commons Attribution 4.0 International (CC BY 4.0) licence.

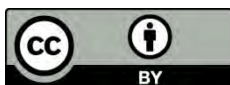

Under this licence you are free, without having to seek our permission, to use this publication in accordance with the licence terms. You must keep intact the copyright notice and attribute the State of Queensland as the source of the publication.

Note: Some content in this publication may have different licence terms as indicated.

For more information on this licence, visit <https://creativecommons.org/licenses/by/4.0/>.

The information contained herein is subject to change without notice. The Queensland Government shall not be liable for technical or other errors or omissions contained herein. The reader/user accepts all risks and responsibility for losses, damages, costs and other consequences resulting directly or indirectly from using this information.

**Interpreter statement:**

The Queensland Government is committed to providing accessible services to Queenslanders from all culturally and linguistically diverse backgrounds. If you have difficulty in understanding this document, you can contact us within Australia on 13QGOV (13 74 68) and we will arrange an interpreter to effectively communicate the report to you.



# Contents

<b>Version history</b>	<b>1</b>
<b>Approval</b>	<b>1</b>
<b>Preliminary</b>	<b>2</b>
<b>Module A – Water meters for surface and underground water</b>	<b>3</b>
<b>Module B – Water level stations</b>	<b>70</b>
<b>Module C – Existing meters for surface water extraction using a small concrete rectangular weir measurement structure</b>	<b>83</b>

# Version history

Version	Date	Comments
1.00	20/11/2014	Minor edits and name change
1.01	18/04/2016	Minor edits
1.02	18/11/2016	Minor edits that include those associated with the Water Regulation and Other Legislation Amendment (i.e. insert Water Regulation 2016 in place of Water Regulation 2012).
1.03	21/4/2017	Minor edit – insert ‘In the absence of other specifications by the meter manufacturer’ in section 2.3.
1.04	16/07/2019	Minor edits and updates to transition the interim standard. Insert 1.1 Transition period, and 2.1.1 Larger meters.
1.05	20/08/2019	Minor edit – insert reference to ‘Guideline: Data logger specifications for water meters’ in section 2.6.
2.00	05/02/2021	Part 2 water level stations added to interim standard, detailing performance requirements for existing and new water level stations. Updated department name to Regional Development, Manufacturing and Water
3.00	30/07/2021	<p>Introduction of Module format to the standard. Module A and Module C replaces Part 1 and Module B replaces Part 2.</p> <p>Module A – Water meters for surface and underground water major rewrite to include measurement assurance requirements; provision for existing meters; Departmental requirements for individual meters; a validation flowchart and a revised Validation Certificate.</p> <p>Module B – Water level stations minor edits to correct typos and clarify measurement requirements.</p> <p>Module C – Concrete rectangular weir measurements added to interim standard detailing assurance requirements, provision for existing measurement, Departmental requirements, a validation flowchart and a new Validation Certificate.</p>
3.01	24/11/2021	<p>Minor edits including reordering of information and minor word changes to improve clarity, and removal of repetitive requirements to only appears once</p> <p>Insertion of Department Requirements for another five individual meters.</p> <p>Rearranged Module B to ensure consistent with the other modules.</p>
3.02	05/09/2022	<p>Minor word changes to improve clarity following feedback from users.</p> <p>Removal of Bermad Turbo IR meter from Table 1 Existing meters.</p>

## Approval

Position	Name	Date
Director, Operational Policy and Measurement	Toni Stiles	5 September 2022

# Preliminary

The *Queensland interim water meter standard for non-urban metering* (this standard) applies to devices used for measuring the take of water.

This standard applies where water entitlement holders are required to have an approved meter as prescribed by the Water Regulation 2016 (Water Regulation) or as a condition of their water entitlement.

Module A of this standard implements the requirements of the *Metrological Assurance Framework 2 Rules and guidance for the use and regulation of non-urban water meters*<sup>1</sup>, in Queensland. Modules B and C are outside the scope of MAF2 but aspire as far as possible to similar measurement outcomes.

---

<sup>1</sup> Department of Agriculture, Water and the Environment, 2021, *Metrological Assurance Framework 2 Rules and guidance for the use and regulation of non-urban water meters*, Commonwealth of Australia, 18 November 2021, <<https://www.awe.gov.au/sites/default/files/documents/metrological-assurance-framework-2.pdf>>.

# Module A – Water meters for surface and underground water

<b>1.0 Application</b>	<b>5</b>
<b>2.0 Output requirement</b>	<b>5</b>
<b>3.0 Measurement assurance requirements</b>	<b>5</b>
3.1 Which water meter can be used	6
3.2 Fit for purpose	8
3.3 Installation	8
3.4 Maintenance	11
<b>4.0 Validation</b>	<b>13</b>
4.1 Validation certificate	13
4.2 Tamper-evident sealing	16
<b>5.0 Meter reading</b>	<b>16</b>
<b>6.0 Workplace health and safety</b>	<b>17</b>
<b>7.0 Disclaimer</b>	<b>17</b>
<b>8.0 References and useful links</b>	<b>18</b>
<b>9.0 Further information</b>	<b>18</b>

## Appendices

<b>Appendix A – Glossary of terms</b>	<b>19</b>
<b>Appendix B – Annual Maintenance Record template (Module A)</b>	<b>22</b>
<b>Appendix C – Individual meters: Departmental requirements</b>	<b>23</b>
<b>Mechanical water meters</b>	<b>24</b>
Multi-Jet	24
NMI14/3/34 WP-Dynamic	24
NMI14/3/44 Arad WSTsb	25
NMI14/3/54 BIL WPD	26
NMI 14/3/57 Bermad Turbo-IR-M	27
Paddle wheel – with no certificate of approval	28
Propellor actuated	29
<b>Electronic water meters</b>	<b>30</b>
Accusonic 8510+	30
Electromagnetic - self-contained, with no certificate of approval	33
Flexim Fluxus F501	35
MACE – XCi & Series II	37
McCROMETER FPI Mag	47
NMI14/3/24 MAG5100W with MAG8000 Transmitter	49
SIEMENS SONO - modular metering system	51

SIEMENS SONO – self-contained	54
SonTek – side-looking water meter	57
<b>Appendix D – Meter installation plans</b>	<b>67</b>

## Tables

Table 1 - Existing water meters	6
Table 2 - New water meters - modular metering systems	7

## Figures

Figure 1 - Two elbows, out of plane	9
Figure 2 - Gravity diversion installation scenario	10
Figure 3 - Non-gravity diversion - full pipe installation configuration	10
Figure 4 - Validation process	14
Figure 5 - Meter installation plan for reduced pipe scenario	67
Figure 6 - Meter installation plan for expanded pipe scenario	67
Figure 7 - Meter installation plan for pump causing spiral flow	68
Figure 8 - Meter installation plan for two elbows, in plane	68
Figure 9 - Meter installation plan for two elbows, out of plane	69
Figure 10 - Meter installation plan for underground water bore - pumped or artesian	69

# 1.0 Application

Module A (this module) of the standard applies to water meters used for the measurement of surface water and underground water extraction, as required by the Department of Regional Development, Manufacturing and Water (the Department).

The following words have an important meaning in the standard:

- Must** Indicates that a statement is mandatory; Australian standards use 'shall' where a statement is mandatory. For this standard we have used 'must' instead of 'shall'.
- May** Indicates the existence of an option.

## 2.0 Output requirement

As a minimum, water meters must generate an electronic pulse output each time a set volume of water passes through the water meter. The output must allow the meter to interface with a transmission device and/or data logger. ModBus output and SCADA system interface meet this requirement.

Mechanical water meters must be fitted with a reed switch (mechanical register) or an electronic register.

The department will notify the relevant person where these devices (data logger and/or transmission device) must be attached to the water meter.

## 3.0 Measurement assurance requirements

Water meters must, at a minimum, comply with the requirements outlined below.

A. A water meter specified in Section 3.1 must be used.
B. Self-contained water meter - After manufacture and prior to being placed into service, a new self-contained water meter must have a calibration/test certificate demonstrating the errors do not exceed $\pm 2.5\%$ across the flow rate range: <ul style="list-style-type: none"><li>i) Most self-contained water meters come with a calibration certificate from the manufacturer, but it is important this is confirmed before purchase of a meter.</li><li>ii) The certificate must show the serial number for the meter.</li></ul>
Modular metering system - A modular metering system must have a test/calibration certificate demonstrating: <ul style="list-style-type: none"><li>i) After manufacture and prior to being placed into service, the errors of new depth/height measurement devices are within the requirements specified by the department for that meter.<ul style="list-style-type: none"><li>- the sensor must be matched to the meter site. For example, for a meter site with a depth range of 3 meters, then a sensor with a depth range of 5 meters would match the site. A sensor with a depth range of 30 meters would not match the meter site.</li></ul></li><li>ii) After manufacture and prior to being placed into service, the errors of new velocity measurement devices are within the requirements specified by the department for that meter.</li><li>iii) The Certificate under i) and ii) must show the serial number for the sensor.</li></ul>
C. Water meters must be suited to the intended purpose, installation configuration and operating conditions (fit-for-purpose) as specified in Section 3.2.
D. Installation of the water meter must comply with the requirements specified in Section 3.3.
E. Periodic maintenance of a water meter must comply with the requirements specified in Section 3.4, and the requirements below.



- i) A self-contained water meter must undergo direct volumetric comparison with a reference device following major maintenance that affects confidence in the meters ability to perform its measurement function.
- ii) A modular metering system must have periodic testing and/or calibration of individual sensors forming part of the system.

F. Post-installation and before water is extracted through a new water meter, the relevant person must engage an authorised meter validator to complete the actions in Section 4 and where the metering installation complies with the requirements of this standard, the authorised meter validator must provide a validation certificate to the relevant person.

G. On an ongoing basis, the relevant person must engage an authorised meter validator to complete the actions in Section 4 and where the metering installation complies with the requirements of this standard, the authorised meter validator must provide a validation certificate to the relevant person.

This process is called revalidation and must be completed within the 12-month period before, and by, the revalidation date published in Schedule 11 of the Water Regulation 2016 (Water Regulation).

H. Auditing must be undertaken by the department or its nominated representative. The details of auditing requirements are generally specified in departmental compliance monitoring plans, but the department may audit at any time and at any frequency deemed necessary.

### 3.1 Which water meter can be used

At all times, the water meter must have a clearly identifiable manufacturer's serial number securely attached or imprinted on the meter.

The water meter must use metric units e.g., kilolitres, megalitres. Where configurable, electronic meters must read in megalitres (ML).

#### 3.1.1 Existing water meters

An existing water meter, shown in Table 1, can continue to be used subject to the other requirements of this module of the standard also being met.

An existing water meter in Table 1, was confirmed to meet the specification under Measurement Assurance Requirement B at the time these metering installations were installed and commissioned.

**Table 1 - Existing water meters**

Operating conditions	Meter type	Make	Model
Full pipe	Multi-jet – self-contained	Arad	MS; M
		Bermad	MT-KD-P
	Paddlewheel – self-contained	Arad	IRT
		Elster; Kent	R1000; R1200
		Raphael; RAF	RMI
	Propeller actuated – self-contained	Bermad	TurboBar
		ABB; Elster; Kent	R2000 ; H4000
	Electromagnetic – self-contained	All makes	All models
	Ultrasonic – Doppler – modular metering systems	Mace	XCi (Series 3); Series 2
	Ultrasonic – Transit time-of-flight	Accusonic	8510+ (modular metering system)
Flexim		Fluxus F501 (modular metering system)	

Operating conditions	Meter type	Make	Model
		Siemens	SONO (self-contained); SONO (modular metering system)
Open channel	Ultrasonic – Doppler, including depth – modular metering systems	Mace	XCi (Series 3); Series 2
		SonTek	Agronaut-SL; SL
	Ultrasonic – Transit time-of-flight, including depth – modular metering systems	Accusonic	8510+
Partially filled pipe	Ultrasonic – Doppler, including depth – modular metering systems	Mace	XCi (Series 3); Series 2
		Accusonic	8510+

Where an existing meter shown in Table 1 fails or becomes faulty and cannot be repaired and successfully complete a process of validation, it must be replaced with a new meter. Refer to Section ‘3.1.2 New or replacement meters - Modular metering systems’ (where applicable) or Section ‘3.1.3 Pattern approved water meters’, for the requirements for new meters.

Where an existing meter is not listed in Table 1 and does not meet the requirements of Section ‘3.1.3 Pattern approved water meters’, it must be replaced with a new meter. Replacement of the new meter must occur within the 12-month period before the revalidation due date shown in Schedule 11 of the Water Regulation 2016. The new meter must comply with the requirements of Section ‘3.1.2 New or replacement meters - Modular metering systems’ (where applicable) or Section ‘3.1.3 Pattern approved water meters’.

### 3.1.2 New or replacement meters - Modular metering systems

Where a new water meter is required the modular metering systems shown in Table 2 can be used subject to any conditions for use shown and the requirements of this module of the standard being met.

Some examples of these meter types are also shown in the table. These are examples only; alternate make and models of these modular metering system meter types may be used, but they must meet the same requirements as the examples provided.

**Table 2 - New water meters - modular metering systems**

Conditions for use	Operating conditions	Meter type	Examples
Meters larger than 600 millimetres only	Full pipe	Electromagnetic – full profile insertion probe, multi-sensor	McCrometer - FPI Mag
		Ultrasonic – Doppler	XCi (Series 3)
		Ultrasonic – Transit time-of-flight	Accusonic - 8510+
			Flexim - Fluxus F501
		Siemens - SONO (modular metering system)	
	Open channel	Ultrasonic – Doppler, including depth	XCi (Series 3)
			SonTek - Argonaut-SL
		Ultrasonic – Transit time-of-flight, including depth	Accusonic - 8510+
	Partially filled pipe	Ultrasonic – Doppler, including depth	XCi (Series 3)
Ultrasonic – Transit time-of-flight, including depth		Accusonic - 8510+	

### 3.1.3 Pattern approved water meters

Where the requirements of Section ‘3.1.1 Existing water meters’ or Section ‘3.1.2 New or replacement meters - Modular metering systems’ are not met then a water meter from the following lists must be used:

- water meters 40mm and smaller: *Certificates of approval - 14 Utility meters 14/3 - Water (utility) meters*
- water meters larger than 40mm in size: *Pattern Approved non-urban Water Meters*.

Use the 'certificate of approval number' from the *Pattern Approved non-urban Water Meters* (water meters larger than 40mm): *Certificates of approval - 14 Utility meters 14/3 - Water (utility) meters*.

See '8.0 References and useful links'.

## 3.2 Fit for purpose

A water meter must meet all 'fit for purpose' requirements of:

- the pattern approval certificate (where there is one)
- the department.

A water meter with a pattern approval certificate has fit for purpose requirements in the certificate. For a selected meter, these are:

- maximum continuous flowrate (Q3)
- minimum flowrate (Q1)
- overload flowrate (Q4)
- limiting condition (Water temperature)
- maximum admissible pressure
- orientation
- installation conditions.

The department's fit for purpose requirements for individual meters/meter types are attached as 'Appendix C – Individual meters: Departmental requirements'.

## 3.3 Installation

For a water meter to comply it must meet all installation requirements of:

- the pattern approval certificate (where there is one)
- the department.

A water meter with a pattern approval certificate has installation conditions in the certificate. For a selected meter, these include:

- orientation
- flow direction
- installation conditions (this includes upstream and downstream lengths).

Where a water meter has a pattern approval certificate, the following elements must not be located within the minimum upstream length specified in the certificate.

- The meter must be installed with the minimum upstream and downstream lengths described for disturbance 3, where these elements—expanded pipe scenario, a gate valve, or similar element—are located upstream of the meter.
- The meter must also be installed with the minimum upstream and downstream lengths described for disturbance type 1 or 2, where the following elements are located upstream of the meter:
  - a butterfly valve, except for the following water meters:
    - NMI14/3/34 WP-Dynamic, see Appendix C for the requirements for this meter
    - NMI14/3/57 Bermad Turbo-IR-M, see Appendix C for the requirements for this meter

- a pump
- elbows-out-of-plane (see Figure 1).

Figure 1 - Two elbows, out of plane

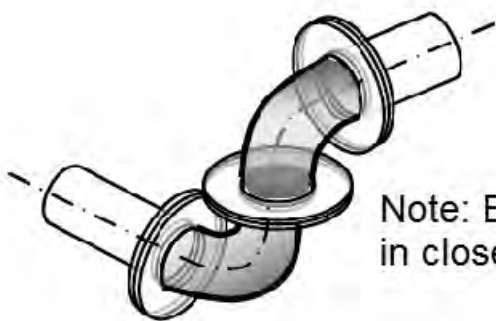

Note: Elbows out of plane installed in close proximity to each other

The department's installation requirements for individual meters/meter types are attached as 'Appendix C – Individual meters: Departmental requirements'.

### 3.3.1 General requirements

Where minimum upstream and downstream pipe lengths are specified, the meter must be provided with straight uniform pipe over these lengths.

Where installed in a pressurised pipe, a self-contained water meter must have isolation valve/s installed to isolate the meter and associated upstream and downstream pipework from the water pressure—allowing for safe and easy removal for inspection and maintenance.

A full pipe or partially filled pipe water meter must have isolation valves, control valves, and all other fittings located outside the required upstream and downstream lengths of pipe.

There must be no offtakes available for water use upstream of the water meter and extracted water must not bypass the meter.

- Where there is an offtake located upstream of a full pipe or partially filled pipe meter:
  - it must be permanently sealed (e.g., metal outlet welded shut)
- or
- tamper-evident sealing must be applied so that the seal must be broken to use this point as an offtake for water use.
- An air release valve, strainer/filter/dirt box, valve, pressure reducing valve etc. located upstream of a full pipe or partially filled pipe meter is not considered an offtake. However, these elements must be tamper-evident sealed so they cannot be removed.
- A pump priming port is not considered an offtake and the port does not require tamper-evident sealing. The pump priming port must only be used for its intended purpose, to prime the pump. It must not be used as an offtake for water use.

Where a full pipe or partially filled pipe water meter does not have a pattern approval certificate and the Department has not specified upstream and downstream length requirements for that meter, the meter must be installed so that the length of straight upstream and downstream pipe sections conform (as a minimum) to the requirements of the meter installation plans shown in Appendix D.

### 3.3.2 Full pipe water meters

Full pipe water meters must be installed so that the meter is full of water while measuring. If a full pipe meter is measuring in a partially filled pipe, it does not meet the requirements of the standard.

An assessment of local operating conditions (e.g., air entrainment, pump cavitation, air ingress, pipework configuration) at the meter site is essential to ensure that full pipe water meters are installed so that the meter is full of water while measuring.

### 3.3.2.1 Gravity diversion

A gravity diversion is where gravity causes water to flow through the water meter.

For gravity-diversions, it must be confirmed that the pipe always runs full when measuring is required.

In the installation scenario shown in Figure 2:

- a pump station is lifting water from a delivery channel
- the water meter is a full pipe type, located in a buried pipe.

**Figure 2 - Gravity diversion installation scenario**

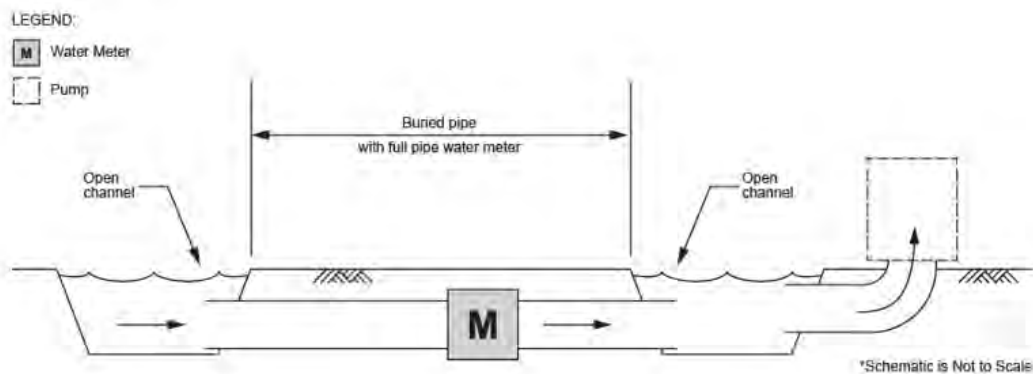

For the scenario shown in Figure 2, a dumpy level survey could be used to confirm the pipe always runs full when measuring is required. For example, the elevation of the top of the buried pipe outlet is confirmed to be at a lower level than the pump suction inlet.

### 3.3.2.2 Non-gravity diversions

A gravity diversion is where gravity causes pipe the water to flow through the water meter. A non-gravity diversion is all other scenarios.

Where an assessment shows that a non-gravity diversion is operating with a partially filled pipe, the installation configuration shown in Figure 3 must be used to ensure a full pipe water meter is full of water while measuring.

Figure 3 shows:

- the water meter is located in a 'U' pipe
- with combination air valve/s upstream at an elevation higher than the meter
- with raised pipework or a flooded outlet, on the downstream side of the meter to ensure the pipe is always running full.

**Figure 3 - Non-gravity diversion - full pipe installation configuration**

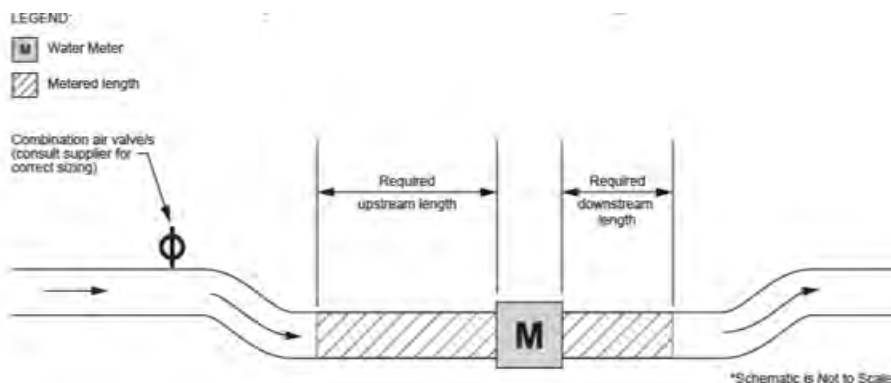

### 3.3.3 Configuration – electronic water meters

Electronic water meters must be configured to meet these general requirements:

- where the device has an internal data logger, this must be enabled
- measurement interval must be 5 minutes or less
- logging interval for measurements must be 60 minutes or less
- date and time must be set to Australian Eastern Standard Time by synchronising the device clock with an electronic device (e.g., computer, or mobile tablet device)
- where software/firmware enhancements occur, these must be upload to the device
- logged data must not be lost, deleted, or reset during maintenance or validation. Prior to update of software/firmware, the configuration setting, the logged data, and the device totals must be downloaded. Where this information is lost because of the update it must be uploaded to the device after the update is complete.

### 3.3.4 Back-flow - mechanical water meters

- Arrow direction marked on the meter must be in the flow direction while measuring water take.
- Where a pipeline reticulation system used by the relevant person connects multiple works with multiple meters measuring water take, to prevent back-flow through a meter a quick-acting mechanical check valve must be installed outside the minimum pipe length requirements of each meter.
- For all other installation scenarios, if there is any risk of water back-flow through the meter a quick-acting mechanical check valve must be installed outside the minimum pipe length requirements of the meter.

## 3.4 Maintenance

Water meters must be maintained to meet department requirements.

Maintenance requirements for individual meters/meter types are attached as 'Appendix C – Individual meters: Departmental requirements'.

The authorised meter validator must prepare a maintenance report as per Section 3.4.1.1.

The relevant person must keep a maintenance log as per Section 3.4.1.2.

### 3.4.1 General requirements

#### 3.4.1.1 Maintenance – authorised meter validator

The following activities must be performed by an authorised meter validator during any process of revalidation (validation – ongoing) or when the meter is faulty. A maintenance report on these activities, confirming completion, must be provided to the relevant person with the validation certificate. The maintenance report can be a checklist and written statement confirming the maintenance activities were completed by the authorised meter validator, and the date they were completed. The checklist must also include the maintenance specified for individual meters in Appendix C.

#### **Solar panel(s)**

- Check solar panel for build-up of material such as dust and bird droppings.
- Check solar panel has tri-spikes (or similar barrier mechanism) installed on the top of the solar panel to reduce the accumulation of bird dropping on the front face of the panel.
- Clean with a wet soft brush or cloth (do not use steel bristle brushes).
- Check solar panel is orientated to the North at the appropriate incline angle, and the panel must not be shaded by trees or structures.

#### **Water meter equipment**

- Where visible and safe to do so, confirm electrical cables and connections are in good working order.

- Confirm register/display is clear and readable.
- For a mechanical water meter, the measuring insert is to be removed:
  - The propellor/paddle/turbine/etc. is checked for damage. Replace measuring insert with a new insert if damaged or replace the meter with a new meter. A new insert must be purchased from the manufacturer.
  - The measuring insert operation is confirmed to be smooth (not binding). Replace measuring insert with a new insert if found to be binding (not smooth) or replace the meter with a new meter (see the standard). A new insert must be purchased from the manufacturer.
  - The meter body (internal) is checked for wear. Install a new water meter where the body has excessive wear.
- Where it is safe to do so, confirm there are no leaks in exposed pipework.
- Where the meter has an internal battery, inspect the 'replace battery by date' on the meter. Replace the battery where required, and record on a tag attached to the meter or write inside a display housing door or lid, replace battery by dd/mm/yyyy. Use permanent ink or a label with permanent ink.
- Complete other maintenance for the meters/meter types as required by the department.

#### 3.4.1.2 Maintenance – relevant person

The following maintenance activities must be performed by the relevant person annually, at a minimum. It is good practice to perform these maintenance activities on a more frequent basis. A maintenance log of these activities must be retained by the relevant person to demonstrate completion. The department may request a copy of the maintenance log as part of an audit process, to confirm maintenance has been completed. The maintenance log is a compilation of a series of annual maintenance records. A blank annual maintenance record is available in Appendix B.

#### **Emplacement / installation / site**

- Keep grass/vegetation around the site at a reasonable height.
- Clear away excess vegetation and debris.
- Confirm the site complies with Workplace Health and Safety requirements to ensure the safety of workers and visitors.
- Confirm the integrity of emplacement, meter supports pipework, and fencing.
- Treat weed and vermin issues.

#### **Solar panels**

- The solar panel must be checked regularly for build-up of material such as dust and bird droppings.
- This activity must be undertaken as often as is necessary to keep the panel clean.
- Clean with a wet soft brush or cloth (do not use steel bristle brushes).

#### **Water meter equipment**

- Where visible and safe to do so, confirm electrical cables and connections are in good working order.
- Confirm register/display is clear and readable.
- For a mechanical water meter, perform a wet test where this is possible, confirming the register rotates smoothly.
- For an electronic water meter, perform a wet test where this is possible, to confirm the display is operating correctly.
- For an electronic water meter, confirm a 'replace-battery-by-date' is recorded on, or attached to, the meter.
- Confirm there are no leaks in exposed pipework or channel structure, and there is no extracted water bypassing the meter, where it is safe to do so.

- Confirm that you believe the meter is recording the volume of water extracted, correctly.
- Confirm the metering installation has mechanical tamper-evident seals, and that none of these seals are broken.

## 4.0 Validation

### 4.1 Validation certificate

Where a water meter meets the requirements of this module of the standard, a validation certificate must be given to the relevant person within 20 business days of an inspection of a water meter by an authorised meter validator.

The relevant person must give a copy of the validation certificate to the Department within 20 business days of receipt of the validation certificate.

Where a water meter does not meet the requirements of this module of the standard, the authorised meter validator must provide the relevant person with a validation notice explaining why and any potential modifications that could allow the meter to become compliant. The relevant person or the authorised meter validator may provide a copy of this notice to the Department.

The Department validation form for this module is *W2F119A Module A – Water meter validation*.

Figure 4 describes the process and actions that must be completed by an authorised meter validator when undertaking a process of validation.



Figure 4 - Validation process

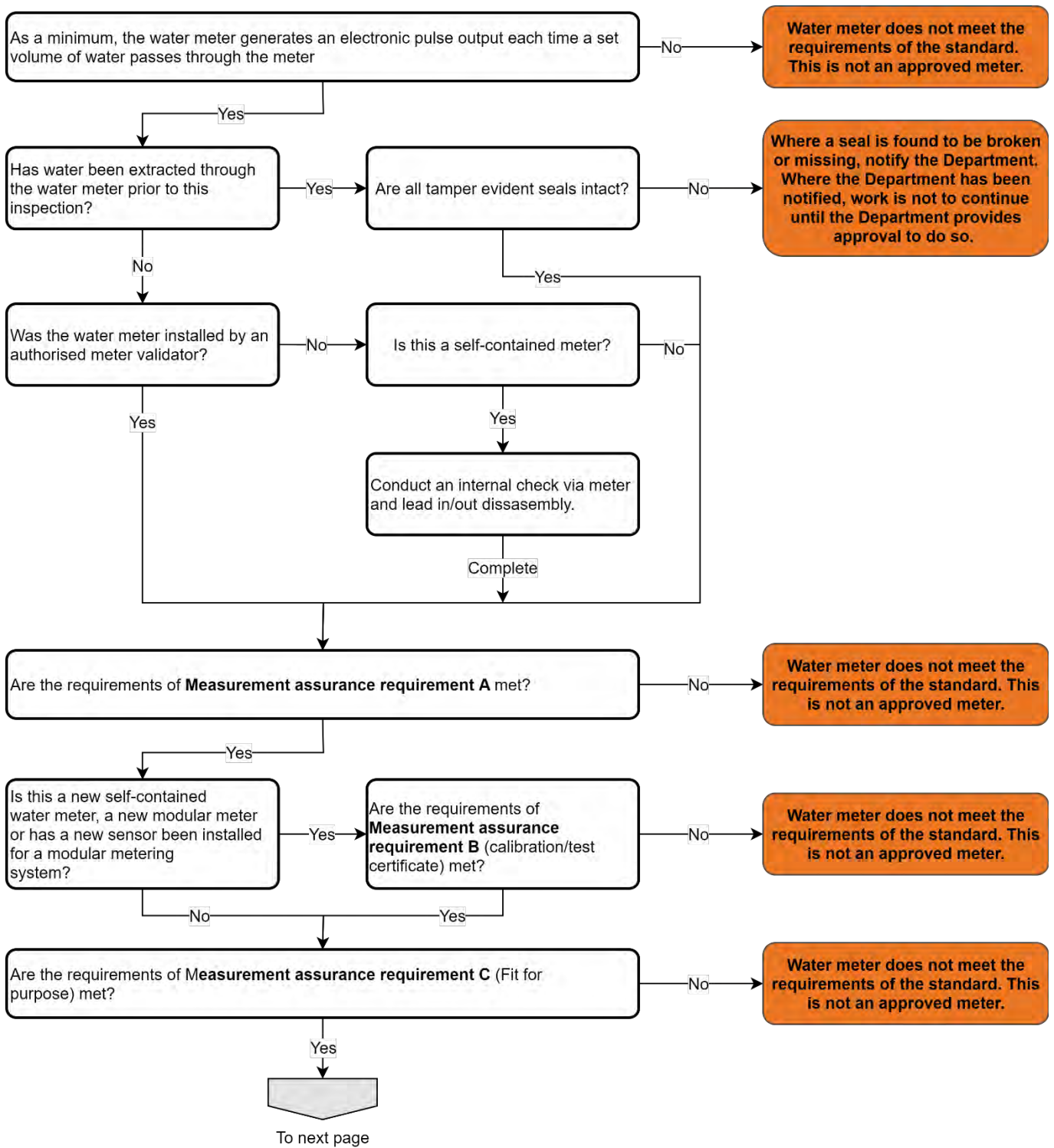

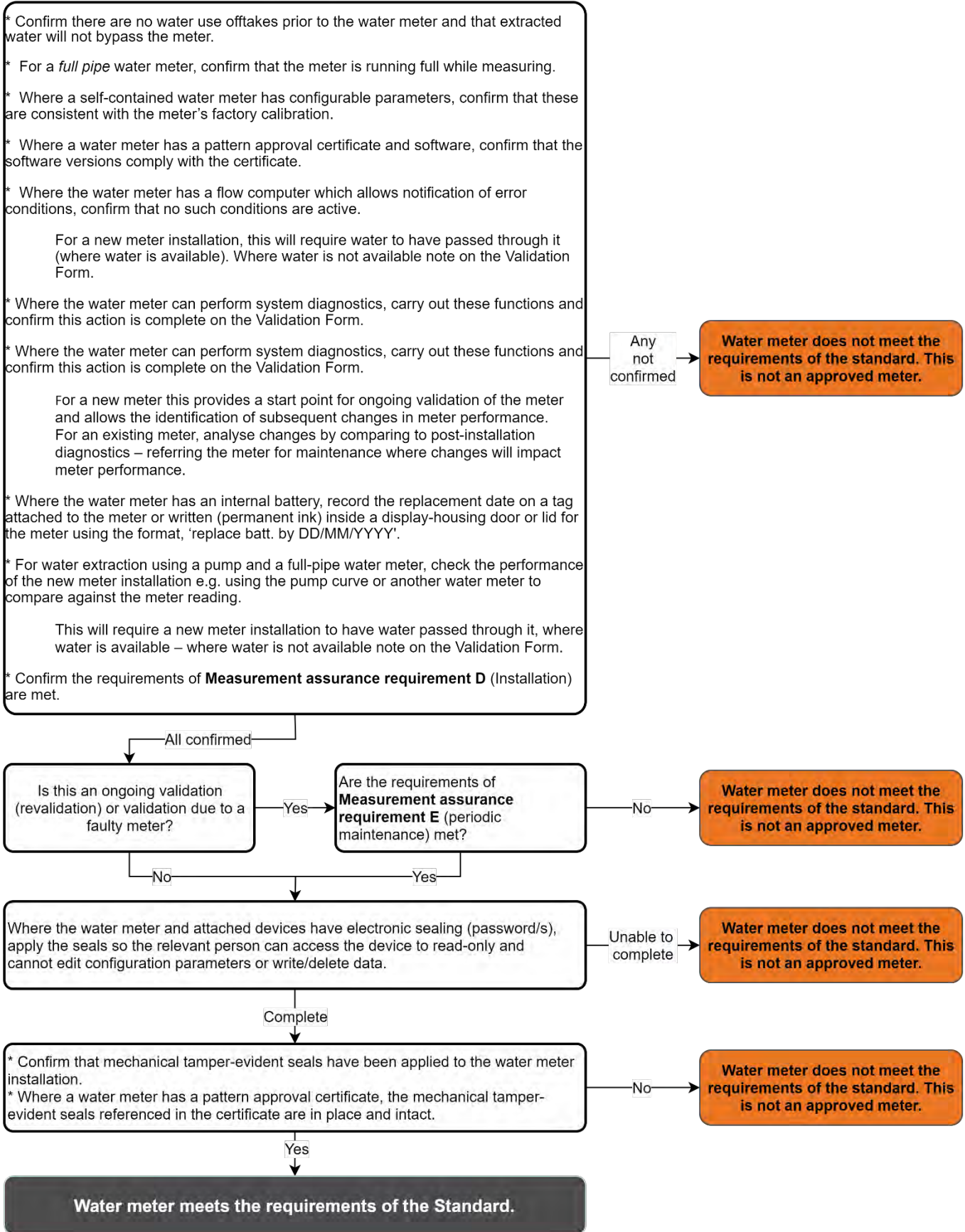

## 4.2 Tamper-evident sealing

Irrigation Australia Limited (IAL) have published national guidelines on tamper-evident sealing of water meters by CMI's. The following requirements are in addition to the IAL requirements.

### 4.2.1 Mechanical seals

Mechanical tamper-evident seals have been applied to:

- lead-in pipework back to the point of extraction
- the meter
- lead-out pipework.

Each mechanical tamper-evident seal applied by an authorised meter validator should have a unique number. The unique numbering allows the department to audit a metering installation and trace the validator that applied each seal. Departmental tracing will occur through IAL and the validator should have arrangements in place with IAL to facilitate this.

For a mechanical water meter, mechanical tamper-evident seals must be applied:

- where a meter uses a reed switch, to the reed switch – the seal must be applied so that it must be broken to remove the reed switch
- to the register, where the register can be removed from the measuring insert – the seal must be applied so that it must be broken to remove the register
- to the measuring insert – the seal must be applied so that it must be broken to remove the insert.

For an electronic water meter:

- the transducers/sensors/flow-tube must have mechanical tamper evident seal(s) applied so that these components cannot be removed or disconnected, without breaking the seal(s)
- the controller/logger/remote-head-unit must have mechanical tamper evident seal(s) applied so that these components cannot be moved, opened, or the transducers/sensors/flow-tube cannot be disconnected, without breaking the seal(s)
- where the meter has an external power supply, this connection must have mechanical tamper evident seals so that the device cannot be disconnected from the supply.

### 4.2.2 Electronic sealing

Where a water meter has a default password from the factory, the authorised meter validator must change the password.

Where the authorised meter validator is uncertain if the relevant person knows the password, they must change the password. The relevant person must not be able to edit, delete or upload, logged data. This also includes configuration settings.

## 5.0 Meter reading

As detailed in Section 2.0 Output requirement, as a minimum, water meters must generate an electronic pulse output each time a set volume of water passes through the water meter. The output must allow the meter to interface with a transmission device and/or data logger.

The department can require data loggers to be fitted to any meter to facilitate more efficient meter reads.

A data logger is a low power device designed to collect and temporarily store readings from a variety of outputs in remote or unattended locations. A logger has an inbuilt clock that timestamps the data entry to allow for data review later.

Installing data loggers on water meters allows for the retrieval of more comprehensive water extraction information. Loggers are installed to:

- minimise the time spent on meter reading
- minimize the cost of meter reading
- capture time and event data
- monitor for water extraction compliance.

Information on data logger requirements can be found in *Guideline: Data logger requirements for water meters for non-urban metering*.

Metered entitlement holders are required to provide a meter reading to the department in accordance with a meter reading notice given under the Water Regulation 2016 and in accordance with the *Queensland Non-urban Water Metering Policy for Unsupplemented Water Extractions 2019*. Entitlement holders will be notified where meter read data must automatically include the date and time that water was extracted (data logger). It is likely that data loggers will be required where:

- water extractions are subject to time and/or passing flow and/or rate of take conditions
- it would support more effective and efficient meter reads.

## 6.0 Workplace health and safety

The *Work Health and Safety Act 2011* (WHS Act) provides a framework to protect the health, safety and welfare of all workers at work. It also protects the health and safety of all other people who might be affected at work.

The WHS Act places the primary health and safety duty on a person conducting a business or undertaking (PCBU). The PCBU must ensure, so far as reasonably practicable, the health and safety of workers at the workplace. Duties are also placed on officers of a PCBU, workers and other persons at a workplace.

With the above requirements in mind, note that a meter installation can be visited by a range of people through-out its service-life. These could include:

- the PCBU
- workers (including an authorised meter validator, fabricators and fitters, mechanics, electricians)
- authorised officers of the department.

## 7.0 Disclaimer

Nothing in the standard is intended to contradict the manufacturer's operating and installation directions that would void manufacturer's warranty or that would indirectly or directly result in loss or liability for which the Department expressly disclaims responsibility.

Any contradiction between the standard and the *Water Act 2000* or Water Regulation 2016 will be managed by the following hierarchy, in order: (i) the *Water Act 2000*, (ii) the Water Regulation 2016, and (iii) the standard.

## 8.0 References and useful links

Department of Industry, Science, Energy and Resources, 2021, 'Certificates of approval - 14 Utility meters', Australian Government, Canberra, viewed 18 November 2021, <<https://www.industry.gov.au/data-and-publications/certificates-of-approval/14-utility>>

Department Regional Development, Manufacturing and Water, 2019, *Queensland Non-urban Water Metering Policy for Unsupplemented Water Extractions 2019*, Queensland Government, Brisbane, 7 June 2021, <[https://www.dnrme.qld.gov.au/?a=109113:policy\\_registry/water-meter-non-urban-unsupp.pdf](https://www.dnrme.qld.gov.au/?a=109113:policy_registry/water-meter-non-urban-unsupp.pdf)>.

Department Regional Development, Manufacturing and Water, 2019, *Guideline: Data logger requirements for water meters for non-urban metering*, Queensland Government, Brisbane, 7 June 2021, <[https://www.dnrme.qld.gov.au/?a=109113:policy\\_registry/guideline-data-logger-requirements.pdf](https://www.dnrme.qld.gov.au/?a=109113:policy_registry/guideline-data-logger-requirements.pdf)>.

Irrigation Australia, 2021, 'Certified Meter Installer & Validator', Brisbane, viewed 7 June 2021, <<https://www.irrigationaustralia.com.au>>.

Murray-Darling Basin Authority, 2021, 'Compliance and enforcement documents', viewed 7 June 2021, <<https://www.mdba.gov.au>>.

National Measurement Institute, 2021, viewed 22 November 2021, <<https://www.industry.gov.au/policies-and-initiatives/national-measurement-institute>>

Murray-Darling Basin Authority, 2020, *Pattern Approved non-urban Water Meters*, Australian Government, Canberra, 22 November 2021 <<https://www.mdba.gov.au/sites/default/files/pubs/pattern-approved-non-urban-water-meters-revised-december-2020.pdf>>

### Legislation

*Water Act 2000* (Qld). Retrieved from <<https://www.legislation.qld.gov.au/view/pdf/inforce/current/act-2000-034>>.

*Work Health and Safety Act 2011* (Qld). Retrieved from <<https://www.legislation.qld.gov.au/view/pdf/inforce/current/act-2011-018>>.

Queensland Water Regulation 2016 (Qld) Retrieved from <<https://www.legislation.qld.gov.au/view/pdf/inforce/current/si-2016-0216>>.

## 9.0 Further information

Further information on water metering is available on the Queensland Government website at <<http://www.business.qld.gov.au>> or call 13 QGOV (13 74 68).

# Appendix A – Glossary of terms

Term	Definition
<b>Air entrainment</b>	Occurs when air bubbles are in the water flow before reaching the pump. It is common where: <ul style="list-style-type: none"> <li>There is free falling discharge near the pump's suction e.g. in a cascading water bore, where the pump is located at a level just below the pumping water level and water cascades (waterfall effect) down from an aquifer above the pumping water level.</li> <li>A pump does not have its minimum suction submergence met e.g. sometimes observed where a vortex forms over the pump suction.</li> </ul>
<b>Air ingress</b>	Where pipework upstream of the pump is subjected to negative pressure, with air entering through gaskets, joints, or fittings e.g. a 'leaky' suction line on a pump.
<b>Authorised meter validator</b>	A person who is accredited by Irrigation Australia Limited as a 'certified meter installer and validator'. A list of people with this accreditation can be found by clicking the 'certified meter installer and validator' tab at < <a href="https://www.irrigationaustralia.com.au">https://www.irrigationaustralia.com.au</a> >. Alternatively, this person can be appointed by the department, where they have the necessary expertise or experience to perform this function.
<b>CMI</b>	An authorised meter validator who is accredited by Irrigation Australia Limited as a 'certified meter installer and validator'. A list of people with this accreditation can be found by clicking the 'certified meter installer and validator' tab at < <a href="https://www.irrigationaustralia.com.au">https://www.irrigationaustralia.com.au</a> >.
<b>Data logger</b>	A low power device attached to the water meter which is designed to collect and store readings (in this instance a pulse or group of pulses from the meter). The device has an inbuilt clock that timestamps each reading, allowing the data to be downloaded and reviewed later. Some water meters have this functionality built into the meter.
<b>Existing meter</b>	A water meter which was installed and commissioned prior to the commencement of this module of the standard.
<b>Full pipe</b>	A closed pipe in which, under normal operating conditions the flow is pressurised in the pipe. A water meter in a full pipe measures the velocity across a fixed cross-sectional area (pipe remains full) to calculate the flow rate passing through the meter.
<b>Installation conditions</b>	For different turbulence conditions: <ul style="list-style-type: none"> <li>the minimum straight length of inlet pipe</li> <li>the minimum straight length of outlet pipe.</li> </ul>
<b>Larger than 600 millimetres</b>	For a self-contained water meter, this is the internal diameter of the meter. For a modular metering system: <ul style="list-style-type: none"> <li>in a round pipe, this is the internal diameter of the pipe at the location of the sensor/s</li> <li>in a non-round pipe, this is an equivalent internal cross-sectional area of the pipe at the location of the sensor/s i.e. greater than 0.283m<sup>2</sup>.</li> </ul>
<b>Limiting condition (water temperature)</b>	The extreme water temperature that a water meter is required to withstand without damage, and without degradation of its required error.
<b>Maximum admissible pressure</b>	The maximum internal pressure that a water meter can withstand permanently, without deterioration of its measurement performance.
<b>Maximum continuous flowrate (Q3)</b>	The highest flowrate at which the water meter is required to operate in a satisfactory manner within the specified errors.
<b>Measuring insert</b>	The measuring element of a self-contained mechanical water meter which inserts into the body of the meter and includes the propellor/paddle/turbine/etc.
<b>Minimum flowrate (Q1)</b>	The lowest flowrate at which the water meter is required to operate with the specified errors.

Term	Definition
<b>Modular metering system</b>	<p>A device or group of instruments that does not define the installation geometry and therefore requires the geometry to be configured as part of installation.</p> <p>For example - the meter has 3 components:</p> <ul style="list-style-type: none"> <li>• A velocity measurement sensor.</li> <li>• A height measurement sensor (to calculate the cross-sectional area) of the water flow.</li> <li>• A controller (calculates the flow rate and logs the measurements and calculations).</li> </ul>
<b>New or replacement meter</b>	A water meter which was installed and commissioned after the commencement of this module of the standard
<b>Open channel</b>	<p>Where the water surface in a channel or pipe always has an air/water interface.</p> <p>A water meter in an open channel measures the velocity across a varying cross-sectional area to calculate the flow rate passing the meter.</p> <p>The depth of water in the channel must also be continuously measured to calculate the cross-sectional area of the water flow at any point in time.</p>
<b>Orientation</b>	A meter can have limitations on how it can be positioned e.g. horizontal only.
<b>Partially filled pipe</b>	<p>Under normal operating conditions, the water surface in the pipe has an air/water interface but under some circumstances, it behaves as a full pipe.</p> <p>A water meter in a partially filled pipe measures the velocity across a varying cross-sectional area to calculate the flow rate passing the meter.</p> <p>The depth of water in the pipe must also be continuously measured to calculate the cross-sectional area of the water flow at any point in time.</p>
<b>Overload flowrate (Q4)</b>	The highest flowrate at which the meter is required to operate, for a short period of time within the specified errors whilst maintaining its measurement performance when it is subsequently operated in the range Q1 to Q3. A short period of time can be considered as 1 hour in any 24-hour period.
<b>Pattern approval certificate</b>	<p>Issued by the National Measurement Institute where a water meter 'passes' the pattern approval process against <i>NMI M 10 – Metrological and Technical Requirements for Meters Intended for the Metering of Water in Full Flowing Pipes</i>.</p> <p>For water meters 40mm and smaller, the meter can pass the pattern approval process against <i>NMI M 49 – Metrological and Technical Requirements for Water Meters Intended for the Metering of Cold Potable Water and Hot Water</i>.</p>
<b>Pattern approval process</b>	<p>Where the National Measurement Institute examines the design of the water meter against a relevant metrological and technical specification. This determines:</p> <ul style="list-style-type: none"> <li>• the measurement accuracy of the water meter</li> <li>• whether the meter retains this accuracy under a range of environmental and operating conditions.</li> </ul> <p>The water meters tamper sealing protections are also considered, to prevent dismantling or modification of the meter without damaging/preventing/memorising these interactions.</p>
<b>Pattern-approved</b>	A water meter that has passed the relevant pattern approval process and has a pattern approval certificate issued by the National Measurement Institute.
<b>Pump cavitation</b>	<p>The formation and subsequent collapse of bubbles or cavities in liquid, developing in area of relatively low pressure around the pump impeller.</p> <p>Cavitation can occur:</p> <ul style="list-style-type: none"> <li>• where filters or strainers are clogged on the suction side of a pump.</li> <li>• with poor pump piping design or poor pump selection.</li> <li>• with poor suction conditions.</li> </ul>
<b>Relevant person</b>	Can be a water authorisation holder, or the owner of works used for taking or interfering with water, or the person nominated to represent them in departmental systems.
<b>Self-contained</b>	A meter that defines its own geometry, is a complete water meter supplied by a single supplier and is calibrated on assembly.
<b>Surface water</b>	<ol style="list-style-type: none"> <li>water in a watercourse or lake or</li> <li>water in a spring not connected to water to which the Water Plan (Great Artesian Basin and Other Regional Aquifers) 2017 applies or</li> <li>overland flow water, other than water in a spring connected to water to which the Water Plan (Great Artesian Basin and Other Regional Aquifers) 2017 applies</li> </ol>

Term	Definition
<b>Transmission device</b>	<p>A device that transmits readings (in this instance a pulse or a group of pulses from the water meter) to a central data store where it can be reviewed in near-real time.</p> <p>The device has an inbuilt clock that timestamps each transmission.</p> <p>This process is sometimes referred to as telemetry.</p> <p>Some water meters have this functionality built into the meter.</p>
<b>Validation</b>	<p>A set of activities performed by an authorised meter validator, that includes:</p> <ul style="list-style-type: none"> <li>• inspecting the meter to confirm it complies with the standard</li> <li>• confirming the meter is installed in compliance with the standard and is maintained to an acceptable state of repair.</li> </ul> <p>Providing confidence that the meter will operate within an acceptable range of error under normal operating conditions.</p>



# Appendix B – Annual Maintenance Record template (Module A)

Maintenance Record – Meter Serial No:		Date of maintenance:
<b>Emplacement / Installation / site</b>	Keep grass/vegetation around the site at a reasonable height	<input type="checkbox"/> Completed <input type="checkbox"/> Not required at this inspection
	Clear away excess vegetation and debris	<input type="checkbox"/> Completed <input type="checkbox"/> Not required at this inspection
	Confirm the site is WHS compliant – safe for workers and visitors	<input type="checkbox"/> Completed
	Confirm integrity of emplacement, meter supports pipework, and fencing	<input type="checkbox"/> Completed
	Treat weed and vermin issues	<input type="checkbox"/> Completed <input type="checkbox"/> Not required at this inspection
<b>Solar panel/s</b>	The solar panel must be checked regularly for build-up of material such as dust and bird droppings - this activity must be undertaken as often as is necessary to keep the panel clean. Clean with a wet soft brush or cloth (do not use steel bristle brushes)	<input type="checkbox"/> Completed <input type="checkbox"/> Not applicable
<b>Water meter equipment</b>	Where visible and safe to do so, confirm electrical cables and connections are in good working order	<input type="checkbox"/> Completed <input type="checkbox"/> Not safe to do so <input type="checkbox"/> Not applicable
	Confirm register/display is clear and readable	<input type="checkbox"/> Completed
	For a mechanical water meter, perform a wet test where this is possible, confirming the register rotates smoothly	<input type="checkbox"/> Completed
	For an electronic (electromagnetic or ultrasonic) water meter, perform a wet test where this is possible, to confirm the display is operating correctly	<input type="checkbox"/> Not possible
	Where it is safe to do so, confirm there are no leaks in exposed pipework or channel structure, and there is no extracted water bypassing the meter	<input type="checkbox"/> Completed <input type="checkbox"/> Not safe to do so <input type="checkbox"/> Not possible
	You believe the meter is correctly recording the volume of water extracted	<input type="checkbox"/> Confirmed <input type="checkbox"/> Notified department – faulty meter
The meter installation has mechanical tamper-evident seals, and none of these seals are broken	<input type="checkbox"/> Confirmed <input type="checkbox"/> Notified department – faulty meter	
Name of person who completed this maintenance:		Signature:
Tick one: <input type="checkbox"/> Water authorisation holder	<input type="checkbox"/> Employee	<input type="checkbox"/> Contractor
		Date:

# Appendix C – Individual meters: Departmental requirements

## Mechanical water meters

<b>Multi-Jet</b>	<b>24</b>
<b>NMI14/3/34 WP-Dynamic</b>	<b>24</b>
<b>NMI14/3/44 Arad WSTsb</b>	<b>25</b>
<b>NMI14/3/54 BIL WPD</b>	<b>26</b>
<b>NMI 14/3/57 Bermad Turbo-IR-M</b>	<b>27</b>
<b>Paddle wheel – with no certificate of approval</b>	<b>28</b>
<b>Propellor actuated</b>	<b>29</b>

## Electronic water meters

<b>Accusonic 8510+</b>	<b>30</b>
<b>Electromagnetic - self-contained, with no certificate of approval</b>	<b>33</b>
<b>Flexim Fluxus F501</b>	<b>35</b>
<b>MACE – XCi &amp; Series II</b>	<b>37</b>
<b>McCROMETER FPI Mag</b>	<b>47</b>
<b>NMI14/3/24 MAG5100W with MAG8000 Transmitter</b>	<b>49</b>
<b>SIEMENS SONO - modular metering system</b>	<b>51</b>
<b>SIEMENS SONO – self-contained</b>	<b>54</b>
<b>SonTek – side-looking water meter</b>	<b>57</b>

For all other electronic pattern-approved water meters, use the SIEMENS MAG5100W example above as the basis for mandatory requirements. The MAG5100W has been used as the example as it is the most common electronic pattern-approved water meter in use at this time.

# Mechanical water meters

## Multi-Jet

The Multi-Jet is a self-contained meter for the measurement of water flow in a full pipe.

The following requirements do not replace the manufacturer requirements. The manufacturer requirements are essential for the successful operation and maintenance of this device and must always be used.

However, for use of this meter under this module of the standard the following requirements must be met, as a minimum, and have been formulated from recommendations/advice in manufacturer literature and where required with input from the manufacturer.

Requirements to be confirmed by validation type	
Ongoing (revalidation) or Faulty meter (maintenance)	Section 2.0

### 1.0 Key terms

Term	Definition
Multi-jet	Arad MS; Arad M; Bermad MT-KD-P

### 2.0 Installation

- Must only be installed in a Horizontal position/orientation.
- For the respective installation scenarios, the meter must be installed in a straight uniform pipe and with the upstream and downstream lengths specified in the Meter Installation Plans in Appendix D – as a minimum.
- Must only be used in a full pipe while measuring.
- Must have a suitable strainer, dirt box or filter where debris is present that could damage or stop the measuring element.

## NMI14/3/34 WP-Dynamic

The WP-Dynamic is a self-contained meter for the measurement of water flow in a full pipe.

The following requirements do not replace Sensus MB 9200 Bulk Meters – Installation Guide or the National Measurement Institute Certificate of Approval NMI 14/3/34. The certificate and installation guide are essential for the successful operation and maintenance of this device and must always be used.

However, for use of this meter under this module of the standard the following requirements must be met, as a minimum, and have been formulated from recommendations/advice in manufacturer literature and where required with input from the manufacturer.

Requirements to be confirmed by validation type	
Post-installation (new or replacement meter)	Section 1.0
Ongoing (revalidation) or Faulty meter (maintenance)	Section 1.0

### 1.0 Installation

Version 3.02 last updated on 05/09/2022

- If the meter is dry during stationary conditions, large volumes of air passing through the meter on pump start can cause excessive wear and inaccuracy in the totaliser and in extreme situations can destroy the meter insert. The pipeline must be filled with water slowly to prevent the meter being damaged by pressure surges.
- Correctly sized air release valve/s must be installed prior to the upstream length of pipe for the meter, where the meter is dry during stationary conditions.
- The meter must be protected from stones, sand, and fibrous material with a suitable strainer, dirt box or filter.
- Where there is no disturbance upstream of the meter, 3 diameters upstream – as a minimum.
- Where the meter is installed as per Figure 1 in the certificate of approval, the butterfly valve must be in the fully open position and the valve not used for throttling of flow. For this installation configuration, the butterfly valve must be held in the fully open position with a tamper-evident seal/s applied. The mechanical tamper-evident seal/s must be applied, so it is broken to move the butterfly valve from the fully open position. For all other instances where a butterfly valve is upstream of the water meter, the meter must be installed with the minimum upstream and downstream lengths described for disturbance type 1 or 2.

## NMI14/3/44 Arad WSTsb

The WSTsb is a self-contained meter for the measurement of water flow in a full pipe.

The following requirements do not replace Woltman Silver Turbo – Technical Sheet or the National Measurement Institute Certificate of Approval NMI 14/3/44. The certificate and technical sheet are essential for the successful operation and maintenance of this device and must always be used.

However, for use of this meter under this module of the standard the following requirements must be met, as a minimum, and have been formulated from recommendations/advice in manufacturer literature and where required with input from the manufacturer.

<b>Requirements to be confirmed by validation type</b>	
<b>Post-installation (new or replacement meter)</b>	Section 1.0
<b>Ongoing (revalidation) or Faulty meter (maintenance)</b>	Section 1.0

### 1.0 Installation

- The meter must be protected from stones, sand, and fibrous material with a suitable strainer, dirt box or filter.
- The meter must have straight pipe sections of the same diameter as the meter. Where there is no disturbance upstream of the meter:
  - For 2” – 6”, 5 diameters upstream and 2 diameters downstream – as a minimum
  - For 8” – 12”, 10 diameters upstream and 5 diameters downstream – as a minimum.

# NMI14/3/54 BIL WPD

The BIL WPD is a self-contained meter for the measurement of water flow in a full pipe.

The following Department of Regional Development, Manufacturing and Water requirements do not replace Zenner WPD - Installation Manual or the National Measurement Institute Certificate of Approval NMI 14/3/54. The certificate and product specification are essential for the successful operation and maintenance of this device and must always be used.

However, for use of this meter under this module of the standard the following requirements must be met, as a minimum, and have been formulated from recommendations/advice in manufacturer literature and where required with input from the manufacturer.

Requirements to be confirmed by validation type	
Post-installation (new or replacement meter)	Section 1.0
Ongoing (revalidation) or Faulty meter (maintenance)	Section 1.0

## 1.0 Installation

- The pipework must be of a design that the meter is protected against pressure surges.
- To prevent damage to the measuring insert caused by pressure surges, the pipe must be filled slowly.
- Correctly sized air release valve(s) must be installed prior to the upstream length of pipe for the meter, where the meter is not filled with water under no-flow conditions.
- The meter must be protected by a suitable strainer, dirt box or filter, so that no foreign particles, such as stone or sand, are flushed into the measuring instrument and cause damage.

# NMI 14/3/57 Bermad Turbo-IR-M

The Bermad Turbo-IR-M is a self-contained meter for the measurement of water flow in a full pipe.

The following requirements do not replace the manufacturer requirements. The manufacturer requirements are essential for the successful operation and maintenance of this device and must always be used.

However, for use of this meter under this module of the standard the following requirements must be met, as a minimum, and have been formulated from recommendations/advice in manufacturer literature and where required with input from the manufacturer.

Requirements to be confirmed by validation type	
Post-installation (new or replacement meter)	Section 1.0
Ongoing (revalidation) or Faulty meter (maintenance)	Section 1.0, Section 2.0

## 1.0 Installation

- Correctly sized air release valve(s) must be installed prior to the upstream length of pipe for the meter.
- Where there is no disturbance upstream of the meter, 5 diameters upstream – as a minimum.
- Where the meter is installed as per Figure 3 in the certificate of approval, the butterfly valve must be in the fully open position and the valve not used for throttling of flow. For this installation configuration the butterfly valve must be held in the fully open position with a tamper-evident seal/s applied. The mechanical tamper-evident seal/s must be applied, so it is broken to move the butterfly valve from the fully open position.
- For all other instances where a butterfly valve is upstream of the water meter, the meter must be installed with the minimum upstream and downstream lengths described for disturbance type 1 or 2.

## 2.0 Maintenance

- As a minimum, the measuring insert is to be replaced every 5 years during revalidation of the meter.

# Paddle wheel – with no certificate of approval

The paddle wheel is a self-contained meter for the measurement of water flow in a full pipe.

The following requirements do not replace the manufacturer requirements. The manufacturer requirements are essential for the successful operation and maintenance of this device and must always be used.

However, for use of this meter under this module of the standard the following requirements must be met, as a minimum, and have been formulated from recommendations/advice in manufacturer literature and where required with input from the manufacturer.

Requirements to be confirmed by validation type	
Ongoing (revalidation) or Faulty meter (maintenance)	Section 2.0, Section 3.0

## 1.0 Key terms

Term	Definition
Paddle wheel	Arad IRT; Elster R1000 / R1200 (Elster Amo or Elster Kent)

## 2.0 Installation

- For the respective installation scenarios, the meter must be installed in a straight uniform pipe and with the upstream and downstream lengths specified in the Meter Installation Plans in Appendix D (as a minimum).
- Must only be used in a full pipe while measuring.
- Correctly sized air release valve(s) must be installed prior to the upstream length of pipe for the meter.

## 3.0 Maintenance

- As a minimum, the measuring insert is to be replaced every 5 years during revalidation of the meter..

# Propellor actuated

The propellor actuated is a self-contained meter for the measurement of water flow in a full pipe.

The following requirements do not replace the manufacturer requirements. The manufacturer requirements are essential for the successful operation and maintenance of this device and must always be used.

However, for use of this meter under this module of the standard the following requirements must be met, as a minimum, and have been formulated from recommendations/advice in manufacturer literature and where required with input from the manufacturer.

## Requirements to be confirmed by validation type

<b>Ongoing (revalidation) or Faulty meter (maintenance)</b>	Section 2.0
---	-------------

## 1.0 Key terms

<b>Term</b>	<b>Definition</b>
<b>Propellor actuated</b>	ABB, Bermad TurboBar; Elster R2000 – flanged only (Kent); Elster H4000 (Kent)

## 2.0 Installation

- For the respective installation scenarios, the meter must be installed in a straight uniform pipe and with the upstream and downstream lengths specified in the Meter Installation Plans in Appendix D (as a minimum).
- Must only be used in a full pipe while measuring.



# Electronic water meters

## Accusonic 8510+

The Accusonic 8510+ Series Flowmeter is a modular metering system for the measurement of water flow in full pipes, partially filled pipes and open channels.

The following requirements do not replace the Accusonic 8510+ Series Flowmeter Technical Reference Manual. The technical manual is essential for the successful installation, operation and maintenance of this device and must always be used.

However, for use of this meter under this module of the standard the following requirements must be met, as a minimum, and have been formulated from recommendations/advice in manufacturer literature and where required with input from the manufacturer.

Requirements to be confirmed by validation type	
<b>Post-installation (new meter installation)</b> <b>Existing meter installation – new controller and new transducers/sensors installed</b>	Table 2 applies – Full pipe meters larger than 600 millimetres only Section 2.0 and Section 3.0
<b>Ongoing (revalidation) or Faulty meter (maintenance) – existing meter installation – new or replacement transducers/sensors only and no new controller</b>	Section 2.0 and Section 3.0
<b>Ongoing (revalidation) or Faulty meter (maintenance) – existing meter installation – new controller and no new transducers/sensors</b> <b>Ongoing (revalidation) or Faulty meter (maintenance) – existing meter installation – no new transducers/sensors and no new controller</b>	Section 2.0

### 1.0 Key terms

Term	Definition
<b>8510+</b>	The controller operates the transducers, measures the travel times between the transducers and calculates the volume of water passing through the meter. It is a modular metering system.
<b>CPH</b>	An Australian Hydrographers Association, Certified Practicing Hydrographer. A list can be found here: Certified Professionals - Australian Hydrographers Association (aha.net.au)
<b>CPH<sub>M</sub></b>	A CPH that has also completed the Meter Installation and Validation course by Irrigation Australia Ltd and is qualified as a Certified Meter Installer and Validator
<b>Controller</b>	The logger/brains of the 8510+.
<b>Transducers</b>	Retrofit acoustic flow transducers

### 2.0 Authorised Meter Validator

From 1 December 2022, an authorised meter validator must have completed training with ACCUSONIC for the 8510+, within the previous 2 years to perform the activities in the following table. The training record/certificate must be provided with the validation certificate where new transducers are installed. This training is essential to achieve the uncertainties published by ACCUSONIC under different operating conditions.

Requirements for	AMV		Training by ACCUSONIC
	Full pipe Partially filled pipe	Open channel	
Fit-for-purpose use of 8510+	CMI	CPH <sub>M</sub> <sup>#</sup>	✓
Number of primary acoustic paths (including crossed paths, where required)	CMI	CPH <sub>M</sub> <sup>#</sup>	✓
Upstream and downstream lengths	CMI	CPH <sub>M</sub> <sup>#</sup>	✓
New transducer selection, installation, and position uncertainty – path length – path angle Diameter, for round pipe Geometry - partially filled pipe / open channel	CMI	CPH <sub>M</sub> <sup>#</sup>	✓
Power supply	CMI	CPH <sub>M</sub> <sup>#</sup>	✓
System calibration	CMI	CPH <sub>M</sub> <sup>#</sup>	✓
Configuration – user defined parameters	CMI	CPH <sub>M</sub> <sup>#</sup>	✓
Data output	CMI	CPH <sub>M</sub> <sup>#</sup>	✓
Maintenance	CMI	CPH <sub>M</sub> <sup>#</sup>	✓

# See Section 2.1 below.

## 2.1 Open channel

Until 1 December 2022, the relevant person must:

- engage a CPH<sup>#</sup>
- nominate their CPH for appointment by the chief executive as an authorised meter validator under s109 of the Water Regulation, for their 8510+.

#The CPH is engaged to complete corrective and preventive maintenance, the installation of new transducers and depth sensors, and validation for their 8510+.

From 1 December 2022, the relevant person must:

- engage a CPH<sub>M</sub><sup>##</sup>.
- nominate their CPH<sub>M</sub> for appointment by the chief executive as an authorised meter validator under s109 of the Water Regulation, for their 8510+.

##The CPH<sub>M</sub> is engaged to complete corrective and preventive maintenance, the installation of new transducers and depth sensors, and validation for their 8510+.

## 3.0 Measurement assurance requirement B

Version 3.02 last updated on 05/09/2022

### 3.1 Transducers

The installation of new transducers must be in accordance with ACCUSONIC procedures and must be completed by authorised meter validators trained by ACCUSONIC.

To ensure uncertainty specifications published by ACCUSONIC are met, the following attributes must be determined according to ACCUSONIC procedures:

- confirming fit-for-purpose
- confirming upstream and downstream lengths
- transducer selection and installation
  - path length measurement
  - path angle measurement
- for round pipe, diameter measurement
- for non-round pipe or irregular shaped pipe, and open channels, geometry measurement
- configuration - user defined parameters.

Confirmation that the attributes above have been determined in accordance with ACCUSONIC procedures, must be provided with the validation certificate. For example, provision of training record/certificate issued by ACCUSONIC (within the previous 2 years).

### 3.2 Depth sensor

New depth sensors must be calibrated after manufacture and prior to installation, and the manufacturer must certify that the sensor will measure depth within  $\pm 0.25\%$  of true value across the depth range.

The new sensor must be provided with a calibration certificate showing the:

- date of the calibration test
- serial number of the reference device
- sensor type, manufacturer part number, and the serial number for the sensor
- depth range over which the sensor was tested
- calibration coefficients i.e., slope and offset, or, that the sensor has 'passed' the test.

# Electromagnetic - self-contained, with no certificate of approval

The electromagnetic (self-contained) are water meters for the measurement of water flow in a full pipe.

The following requirements do not replace the operating manual of the manufacturer. The manual is essential for the successful installation, commissioning, operation, and maintenance of these devices, and must always be used.

However, for use of these water meters under this module of the standard the following requirements must be met, as a minimum, and have been formulated from recommendations/advice in manufacturer manuals and where required with input from the manufacturer.

## Requirements to be confirmed by validation type

<b>Ongoing (revalidation) or Faulty meter (maintenance)</b>	Section 2.0, Section 3.0, Section 4.0, Section 5.0, and Section 6.0
---	---

## 1.0 Key terms

Term	Definition
<b>Controller</b>	The transmitter/logger/ brains of the device
<b>Electromagnetic</b>	A self-contained water meter with a transmitter/controller, that operates a magnetic field in a flow tube/flow sensor, interprets the signal from the sensor and calculates the volume of water passing through the meter.
<b>Flow sensor</b>	The water passes through this component, which has an electromagnetic field and provides a signal to the controller.

## 2.0 Installation

- The flow sensor must not be located where another magnetic field is present.
- The cable length and cable shielding, between the flow sensor and controller must be in accordance with manufacturer recommendations or specification.
- Arrow direction must be in the flow direction.
- Where there is no disturbance upstream, the water meter must be installed in a straight uniform pipe:
  - 5 times nominal diameter of the meter must be upstream of meter coupling (as a minimum)
  - 3 times nominal diameter of the meter must be downstream of meter coupling (as a minimum).
- For all other installation scenarios, the water meter must be installed in a straight uniform pipe in accordance with manufacturer recommendations or specification.
- Must only be used in a full pipe while measuring.
- Must only be mounted in the orientation shown on the water meter data plate. Where orientation is not shown, a horizontal orientation must be used.

## 3.0 Configuration

### 3.1 Calibration settings

Confirm the calibration settings for the electromagnetic are consistent with the water meters factory calibration certificate/report.

### 3.2 Alarms

Where the water meter can activate alarms for the following faults, these must be switched on:

Alarm	Description
<b>Insulation</b>	An insulation fault with the coil current and the electrodes reading each other.
<b>Coil current</b>	An error in the coil e.g., the coils have been disconnected.
<b>Amplifier overload</b>	Instability in the electrode circuit e.g., the electrode(s) have been disconnected.
<b>Checksum</b>	Checksum test shows corrupted or invalid data. May indicate a failed printed circuit board or a damaged/defective transmitter.
<b>Lower power / low battery</b>	Battery capacity is below pre-set threshold.
<b>Empty pipe</b>	Flow sensor is not full of water.

## 4.0 Output

Where the department requires meter health as an output from the meter:

Where not already incorporated into the Electromagnetic, a serial communication module must be added to the water meter in accordance with manufacturer's requirements. To have a validation certificate issued, where an electromagnetic:

- is installed after this document came into effect, it must have a serial communication module installed as part of validation post-installation
- was installed prior to the effect of this document, it must have a serial communication module installed as part of the next process of validation for the meter

The serial communication module provides serial output (allows the notification of alarms e.g., low battery) from the electromagnetic for interface with transmission devices.

Where the department requires pulse output only from the water meter:

The electromagnetic must have the pulse output connection in place, which registers a pulse each time a set volume of water passes through the meter. To have a validation certificate issued, where electromagnetic:

- is installed after this document came into effect, it must have the pulse output connection in place and configured as part of the process of validation, post-installation
- was installed prior to the effect of this document, it must have a pulse output connection in place and configured as part of the process of ongoing validation (revalidation) of the electromagnetic

The pulse output connection allows the meter to interface with third party transmission devices.

## 5.0 Maintenance

The electromagnetic internal battery must be replaced every 5 years, as a minimum, regardless of perceived battery status.

# Flexim Fluxus F501

The Flexim Fluxus F501 is a modular metering system for the measurement of water flow in full round pipes.

The following requirements do not replace the User Manual for the Fluxus F501. The user manual is essential for the successful installation, operation and maintenance of this device and must always be used.

However, for use of this meter under this module of the standard the following requirements must be met, as a minimum, and have been formulated from recommendations/advice in manufacturer literature and where required with input from the manufacturer.

Requirements to be confirmed by validation type	
<b>Post-installation (new meter installation)</b> <b>Existing meter installation – new transmitter and new transducers installed</b>	Table 2 applies – Full pipe meters larger than 600 millimetres only Section 2.0 and Section 3.0
<b>Ongoing (revalidation) or Faulty meter (maintenance) – existing meter installation – new or replacement transducers only and no new transmitter</b>	Section 2.0 and Section 3.0
<b>Ongoing (revalidation) or Faulty meter (maintenance) – existing meter installation – new transmitter and no new transducers</b> <b>Ongoing (revalidation) or Faulty meter (maintenance) – existing meter installation – no new transducers and no new transmitter</b>	Section 2.0

## 1.0 Key terms

Term	Definition
<b>F501</b>	The transmitter operates the transducers, measures the travel times between the transducers and calculates the volume of water passing through the meter. It is a modular metering system.
<b>Transmitter</b>	The logger/brains of the F501.
<b>Transducers</b>	Retrofit sound transducers

## 2.0 Authorised Meter Validator

From 1 December 2022, an authorised meter validator must have completed training with FLEXIM for the F501, within the previous 2 years to perform the activities in the following table. The training record/certificate must be provided with the validation certificate where new transducers are installed. This training is essential to achieve the uncertainties published by FLEXIM.

Requirements for	CMI	Training by FLEXIM
Fit-for-purpose use	✓	✓
Number of sound paths and arrangement for transducers	✓	✓
Upstream and downstream lengths	✓	✓
New transducer position, installation, and uncertainty – transducer spacing length – transducer position on pipe - path angle – diameter, for round pipe	✓	✓
Power supply	✓	✓
System calibration	✓	✓
Configuration – user defined parameters	✓	✓
Data output	✓	✓
Maintenance	✓	✓

### 3.0 Measurement assurance requirement B

The installation of new transducers must be in accordance with FLEXIM procedures and must be completed by CMI's trained by FLEXIM.

To ensure uncertainty specifications published by FLEXIM are met, the following attributes must be determined according to FLEXIM procedures:

- installation
- position of transducers on pipe
- length between transducers measurement
- path angle measurement
- diameter measurement.

Confirmation that the attributes above have been determined in accordance with FLEXIM procedures, must be provided with the validation certificate. For example, provision of training record/certificate issued by FLEXIM (within the previous 2 years).

# MACE – XCi & Series II

The XCi is a modular metering system for the measurement of water flow in full pipe, partially filled pipe and an open channel.

The following requirements do not replace the XCi Product Manual or the FloSeries II Product Manual. The manuals are essential for the successful installation, commissioning, operation, and maintenance of these devices, and must always be used.

However, for use of these meters under this module of the standard the following requirements must be met, as a minimum, and have been formulated from recommendations/advice in the manual and where required with input from the manufacturer.

Requirements to be confirmed by validation type	
<b>Post-installation - new meter installation</b> <b>Existing meter installation – new logger and new sensor/s installed</b>	Table 2 applies – Full pipe meters larger than 600 millimetres only.  Section 2.0, Section 3.0, Section 4.0, Section 5.0, Section 6.0, Section 7.0, Section 8.0, Section 9.0, and Section 10.0
<b>Ongoing (revalidation) or Faulty meter (maintenance) – existing meter installation - new or replacement sensors only and no new logger</b>	Section 2.0, Section 3.0, Section 4.0, Section 5.0, Section 6.0, Section 7.0, Section 8.0, Section 9.0, and Section 10.0
<b>Ongoing (revalidation) or Faulty meter (maintenance) – existing meter installation - new logger only and no new or replacement sensors</b>  <b>Ongoing (revalidation) or Faulty meter (maintenance) – existing meter installation - no new or replacement logger and no new or replacement sensors</b>	Section 4.0, Section 5.0, Section 6.0, Section 8.0, Section 9.0, Section 10.0, and Section 11.0

Note: The requirements only reference the XCi but these requirements must also be met with any Series II. Where the requirements cannot be met with the Series II, this has been noted.

## 1.0 Key terms

Term	Definition
<b>Area / velocity sensor</b>	MACE Doppler ultrasonic strap mount area/velocity sensor
<b>Depth sensor</b>	As a component of the area / velocity sensor, or a stand-alone third-party sensor
<b>Insert velocity sensor</b>	MACE Doppler ultrasonic insert velocity sensor
<b>Non-insert velocity sensor</b>	MACE Doppler ultrasonic strap mount velocity-only sensor
<b>XCi</b>	The MACE AgriFlo XCi or FloPro XCi including connected sensors.
<b>Logger</b>	The controller/logger component of the XCi
<b>Velocity sensor</b>	Insert velocity sensor, non-insert velocity sensor, and area / velocity sensor



## 2.0 Authorised Meter Validator

From 1 December 2022, a CMI must have completed training by MACE for the XCi, within the previous 2 years to perform the activities in the following table. The training record/certificate must be provided with the validation certificate where a new sensor is installed.

Activity	CMI	Training by MACE
Installation of new sensors	✓	✓
Velocity sensor check for a new velocity sensor	✓	✓

## 3.0 Measurement assurance requirement B

### 3.1 Velocity sensor

New velocity sensors must be calibrated after manufacture and prior to installation, and the manufacturer must certify that the sensor will measure velocity within  $\pm 2.5\%$  of true value across the velocity range.

The new sensor must be provided with a calibration certificate showing:

- date of the calibration test
- the serial number of the reference meter
- the sensor type, manufacturer part number, and the serial number for the sensor
- the velocity range over which the sensor was tested
- pass/fail.

With the installation of a new sensor a velocity sensor check (3.2) must also be completed.

A new velocity sensor must undergo a velocity sensor test (see 8.0 Velocity Sensor Test).

### 3.2 Velocity sensor check

Where a new sensor has been installed, a XCi must have a minimum of 10 real time graph measurements viewed and saved, while extraction is occurring.

The graphs must show an 'ideal' bell shape centred across the velocity range with the range set to double the average velocity.

If water extraction is occurring at the time that validation is being undertaken, a minimum of 10 graphs must be viewed, saved, and provided to the relevant person with the validation certificate.

If water extraction is not occurring at the time that validation is being undertaken, during the next extraction event a minimum of 10 graphs must be viewed, saved, and provided to the relevant person within 20 days of the extraction event.

The department will request another validation certificate if the real-time graphs are not provided to the department by the relevant person, within 40 business days of the next extraction event.

### 3.3 Depth sensor

New depth sensors must be calibrated after manufacture and prior to installation, and the manufacturer must certify that the sensor will measure depth within  $\pm 0.25\%$  of true value across the depth range.

The new sensor must be provided with a calibration certificate showing the:

- date of the calibration test
- serial number of the reference device
- sensor type, manufacturer part number, and the serial number for the sensor

Version 3.02 last updated on 05/09/2022

- depth range over which the sensor was tested
- calibration coefficients i.e., slope and offset, or, that the sensor has 'passed' the test.

## 4.0 Fit for purpose

### 4.1 General

A velocity sensor must only be used to measure extractions from stream flow with sufficient acoustically reflective particles such as sand, silt, dirt, leaves and/or air bubbles. The stream must contain at least 100 parts per million of acoustically reflective particles that are greater than 75 microns in size, noting most natural environments usually have sufficient reflective particles suspended.

A velocity sensor must not be:

- used in full pipe with a pressure greater than 25 meters head, at/on the sensor,
- used to measure velocities more than 8 metres per second,
- used for underground water measuring applications,
- installed within 25 meters of another acoustic flow meter in the same pipe/open channel.

### 4.2 Insert velocity sensor

The sensor must be:

- installed in a ball valve
- easily accessed on the outside of the pipe for servicing and maintenance (not buried).

The sensor must not be:

- installed in a round pipe with an internal diameter greater than 2.5 meters or where a pipe is not round with a cross-section area greater than 4.9 m<sup>2</sup>
- used for open channel metering.

### 4.3 Non-insert velocity sensor and Area / velocity sensor

These sensors must not be used in an open channel with a maximum width greater than 10 meters. For example, for a trapezoidal channel the maximum width of the channel during full flow must not exceed 10 meters.

These sensors must only be used with these regular channel geometries:

- concrete lined open channels
- concrete lined rectangular or trapezoidal culverts
- natural lined open channels with near-trapezoidal shape
- round and elliptical pipes.

These sensors must not be used with:

- natural streams with complicated cross-sectional geometry
- complicated flow structures.

## 4.4 Installation conditions

### 4.4.1 Full pipe and partially filled pipe

For a uniform pipe with no upstream disturbance (for example no valves/bends/pumps upstream) the velocity sensor must be installed to these minimum straight length requirements.

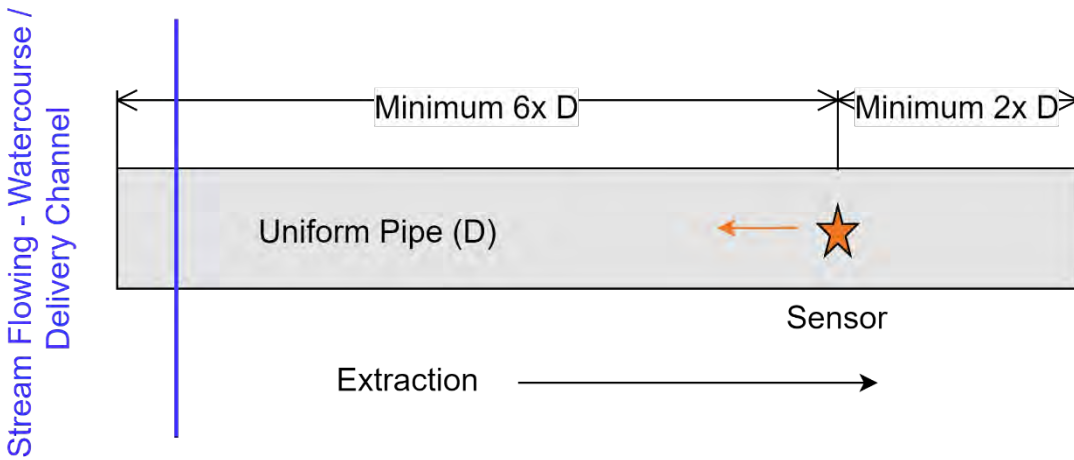

For all other installation scenarios, the velocity sensor must be installed with the upstream and downstream lengths specified in the Meter Installation Plans in Appendix D – as a minimum.

### 4.4.2 Open channel

For a uniform channel with no upstream disturbance (i.e., no sharp bends/angled undershot gate) the velocity sensor must be installed to these minimum straight length requirements.

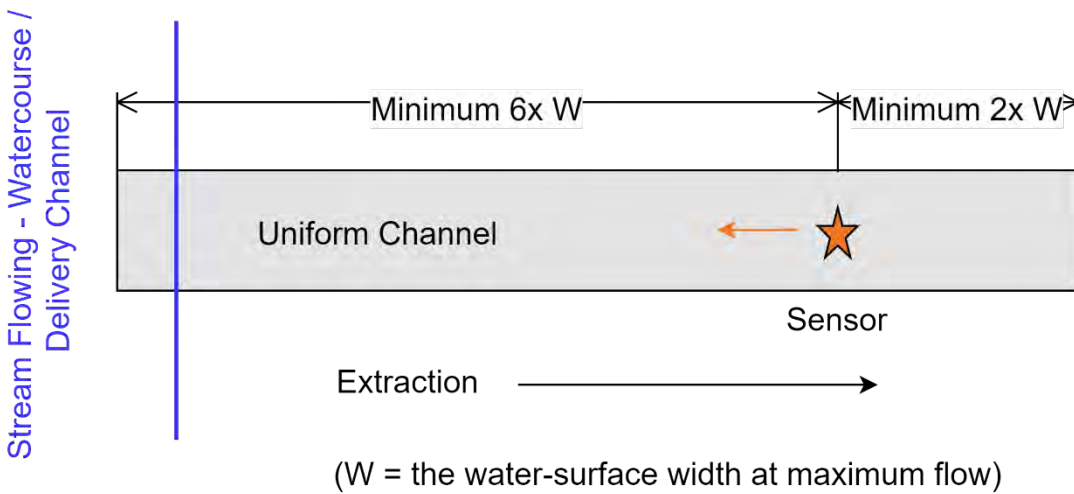

Where there is upstream disturbance (i.e., high velocity flow via a sharp bend/there is an angled sluice gate) upstream, the velocity sensor must be installed to these minimum straight length requirements.

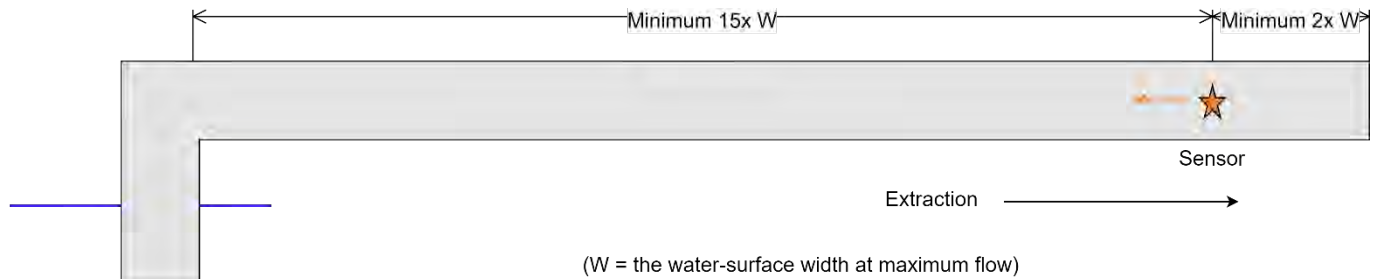

#### 4.4.3 Depth sensor – stand-alone

Note: Series II does not have this functionality.

Where required, a depth sensor can be a third-party sensor.

Any third-party sensor must:

- connect to the XCi, where measurements must be logged
- obtain power from the XCi.

## 5.0 Installation

### 5.1 General

The XCi must:

- Water damage – be mounted above known flood peak levels. The XCi must not be submerged.
- Sunlight - be mounted so that the LCD faces in a direction away from direct sunlight (i.e., LCD must face South).
- Cable damage – have all cables appropriately routed through electrical conduit when not enclosed in any mounting pole.
- Insects and moisture – have a non-curing sealing compound (e.g., duct-seal-putty) installed down the first 5 to 10 cm of electrical conduit or the mounting pole where cables are enclosed, to prevent insect/moisture ingress.
- Power – have an alternate DC source of 16-30V DV connected to the XCi power regulator to charge the internal battery (i.e., a solar panel). The cables from the solar panel to the XCi must be enclosed in electrical conduit when not enclosed in any mounting pole (see Insect and moisture requirement above).
- Solar panel - have tri-spikes installed on the top of the solar panel to reduce the accumulation of bird droppings on the front face of the panel; and the solar panel orientated to the North at the appropriate incline angle, and the panel must not be shaded by trees or structures.

### 5.2 Doppler ultrasonic velocity sensor

The sensor cable must not:

- be cut. Re-termination of the sensor is highly specialised and must be carried out at a MACE technical facility.
- have any connections between the sensor and the XCi (so the sensor cannot be disconnected inadvertently or to facilitate fraud).

## 5.3 ZX SnapStrap

A correctly sized ZX SnapStrap must be used (see the XCi - Product Manual).

In round pipe the strap must be permanently affixed to the inside of the pipe.

## 5.4 Bespoke strap mount

The CMI can choose to use a bespoke strap mount in a pipe.

The sensor must mount through countersunk holes in the strap (using the same principles as for mounting of a sensor in a ZX SnapStrap)

The strap must be permanently affixed to the inside of the pipe (e.g., bolted/screwed through/to the pipe wall or mounted using adhesive (or equivalent)).

## 5.5 Mounting plate

The MACE mounting plate must be used in pipe greater than DN800 (or equivalent), and for open channel installations.

It must be permanently affixed (e.g., bolted/screwed through/to the pipe wall, bolted/screwed to a concrete pad or mounted using adhesive (or similar product)).

'Or equivalent' in this instance means, in round pipe with an internal diameter greater than 800mm or a non-round pipe with a cross-section area exceeding 0.503m<sup>2</sup>.

## 5.6 Depth sensor – stand-alone

Note: Series II does not have this functionality.

The sensor cable must not have any connections between the sensor and the logger (so the sensor cannot be disconnected inadvertently or to facilitate fraud).

# 6.0 Configuration

## 6.1 Site ID

Must be the logger serial number.

Where more than one logger are required at the metering location, use the lowest serial number, and record the other logger serial number(s) on the validation certificate.

Note: the Series II does not have the following functionality.

The following example describes where more than one logger could be required for the XCi. In this example, there are six velocity sensors. For each of these sensors a Doppler card is required to be installed in the logger to convert the signal received from the sensor to a velocity measurement. One logger has five card slots only, with one of these devoted to data output (refer to 12.0 Output) – leaving four card slots for Doppler cards to be installed. Therefore, a second logger would be required for the remaining two Doppler cards.



When a validation certificate is provided for the XCi, it must link:

- the logger serial number (Site ID), to the
- water resource extraction authorisation number(s), to the
- works number(s) for extraction occurring against an authorisation, to the
- latitude and longitude for the meter location
- the serial number/s for the sensor/s connected to the logger/s.

Where the controller card is replaced, the serial number for the new card must be linked to the metering site with a validation certificate. The new serial number must be permanently recorded inside the logger using a label or tag.

## 6.2 The XCi channels

The XCi uses channels to enable various measurements to be made and other parameters to be calculated. There are three types of channels:

- Connected sensor channels – these channels output the measured value based on the signal received from physically connected sensors wired to the logger.
- Calculated channels – these channels use the measured values (connected sensor channels) and apply an algorithm(s) to output calculated values.
- System channels – these channels use system values direct from the logger.

### 6.2.1 XCi – water meter

There are two primary measurement configurations where the XCi is used as a water meter.

**CONFIGURATION 1:** Measurement of velocity, with flowrate calculated by multiplying by a fixed cross-sectional area of flow (full pipe).

- A Doppler ultrasonic velocity sensor signal is converted to a velocity output by the logger using a 'velocity channel'.
- The velocity output is then used to calculate flowrate via a 'flowrate channel' by multiplying by a fixed cross-sectional area of flow.

CONFIGURATION 2: Measurement of velocity and depth of flow, with flowrate calculated by multiplying by a calculated cross-section area of the flow (partially filled pipe and open channel).

- A Doppler ultrasonic velocity sensor signal is converted to a velocity output by the logger using a ‘velocity channel’.
- A depth sensor signal is converted to a depth output by the logger using a ‘depth channel’.
- The velocity output is then used to calculate flowrate via a ‘flowrate channel’ by multiplying by a calculated cross-sectional area of flow.

Following are minimum requirements for ‘Channels’ to be configured and confirmed for the meter installation. The requirements are based on the two basic measurement configurations for the XCi (described above) as a water meter.

Channels	Channel type	Configuration 1	Configuration 2
<b>Velocity</b>	Connected sensor	✓	✓
		The ‘monitor status’ checkbox must be ticked.## / ##	
<b>Doppler stream index</b>	System	✓	✓
<b>Depth</b>	Connected sensor	✘	✓
<b>Flowrate (using velocity)</b>	Calculated	✓	✓
<b>Total flow</b>	Calculated	✓	✓
		The ‘non-resettable’ check box must be ticked.## The ‘total positive flow’ check box must be ticked.	
<b>Net flow total</b>	Calculated	✓	✓
		The ‘non-resettable’ check box must be ticked.## The ‘all values’ check box must be ticked.	
<b>Device battery voltage#</b>	System	✓	✓
<b>Device external voltage#</b>	System	✓	✓

# Essential meter health elements, i) velocity sensor working, and ii) the XCi internal battery and alternate DC power source voltage, making it easier to identify if the meter is/when the meter became faulty.

## Essential tamper-evident/prevention elements, i) logging when a velocity sensor is disconnected or stops working, and ii) stopping unauthorised persons from resetting the XCi totals. Either inadvertently or to facilitate fraud.

## 7.0 Geometry

The cross-sectional area must be determined and/or confirmed at the sensor location whenever a new sensor is installed. A report on this activity, confirming completion, must be provided to the relevant person with the validation certificate.

### 7.1 Cross-sectional area – non-round or irregular shaped pipe, and open channel

The intervals for the measurement of depth must not be greater than 1/20 of the width when establishing the depth to cross-sectional area algorithm.

Where the pipe/channel cross-section is uniform equal spacing between the vertical measurements is appropriate.

Where the pipe/channel cross-section is not uniform, the location of the verticals must be chosen so that the discharge in each segment is less than 5% of the total, in so far as possible and not exceed 10%.

## 8.0 Velocity sensor test

A MACE Doppler Sensor test kit must be used, and a digital multimeter capable of reading capacitance (<2nF range) and resistance (>20MΩ).

The sensor must produce capacitance and resistance values within the ranges specified in the AgriFlo XCi User Manual to remain in service.

Where a sensor fails the test, it must be replaced with a new sensor.

A report on this activity, confirming completion, is to be provided to the relevant person with the validation certificate.

## 9.0 Depth sensor check

The sensor "offset" must be confirmed and checked. The offset is the level that the sensor is positioned relative to the silt/sediment/bed level within a pipe or channel.

Where the water level is over the sensor, the reading must also be confirmed against another measurement device. For example, a tape or ruler.

Where the water level is not over the sensor, the sensor must be confirmed to be reading correctly against another measurement device. For example, submerging the sensor and confirming the level matches that of a tape or ruler.

Where the sensor fails the check, a new sensor must be installed.

A report on this activity, confirming completion, is to be provided to the relevant person with the validation certificate.

## 10.0 Output

Note: Series II does not have the following functionality, but it does provide a basic pulse output which must be confirmed to be operating.

Where the department requires meter health as an output from the meter:

The logger must have a FloSI card installed. To have a validation certificate issued, where an XCi:

- is installed after this document came into effect - it must have a card installed as part of validation post-installation
- was installed prior to the effect of this document - it must have a FloSI card installed as part of the next process of validation for the XCi.

The FloSI Card provides output from the logger for interface with third party transmission devices.

A WebComm card may be used where the department confirms this is possible. This card provides cellular output from the logger to the Department's nominated data platform.

Where the department requires pulse output only:

The logger must have a Pulse I/O card installed. To have a validation certificate issued, where an XCi:

- is installed after this document came into effect - it must have a Pulse I/O card installed as part of the process of validation, post-installation
- was installed prior to the effect of this document - it must have a Pulse I/O card installed as part of the next process of validation for the XCi.

The Pulse I/O card provides output from the logger for interface with third party transmission devices.

## 11.0 Maintenance

Version 3.02 last updated on 05/09/2022



## 11.1 Velocity sensor cleaning

The velocity sensor must be kept free of built-up debris, silt, or grease:

This is done using a stiff bristle brush (do not use steel bristle brushes) and carefully cleaning the sensor head and surrounding area

## 11.2 Battery replacement

Note: the Series II does not have a logger control panel battery.

The XCi internal battery must be replaced every 5 years, as a minimum, regardless of perceived battery status.

The logger control panel battery must be replaced when the internal battery is replaced, regardless of perceived battery status.

## 11.3 Area/velocity sensor

### 11.3.1 Reference filter

To keep the depth sensor component of this sensor working as required the vent tube must always remain free from moisture.

The silica gel crystals contained within the reference filter effectively entrap atmospheric moisture. However, these crystals require changing regularly to ensure that they are still effective.

The silica gel crystals used in the reference filter are an indicator type. When fresh they are a deep blue in colour and when exhausted they are light pink.

Inspect the crystals. Where the crystals indicate they are nearing exhaustion they must be replaced at the time of inspection.

### 11.3.2 Depth sensor

Due to the presence of silt, large gravel and debris, the depth sensor component of this sensor can be physically damaged through impact of large debris.

Inspect the depth sensor.

Where the depth sensor component is found to be damaged and/or not operating, it must be replaced with a new sensor.

## 11.4 Geometry – gravity diversion

From 31 October 2023, where gravity causes the water to flow past or through a XCi, the geometry of the pipe or channel must be remeasured between 1 April and 30 October, where extraction occurred during the preceding period of 1 November to 31 March. Reporting on this activity is to be included in the maintenance report, confirming completion, and must be provided to the relevant person with the validation certificate.

Note: requirements for non-round or irregular shaped pipe, and open channel are shown in 7.1.

# McCROMETER FPI Mag

The McCROMETER FPI Mag is a modular metering system for the measurement of water flow in full round pipes.

The following requirements do not replace the McCROMETER Full Profile Insertion Electromagnetic Flow Meter Installation, Operation and Maintenance Manual. The manual is essential for the successful installation, operation and maintenance of this device and must always be used.

However, for use of this meter under this module of the standard the following requirements must be met, as a minimum, and have been formulated from recommendations/advice in manufacturer literature and where required with input from the manufacturer.

Requirements to be confirmed by validation type	
<b>Post-installation (new meter installation)</b> <b>Existing meter installation – new FPI Mag sensor and new converter</b>	Table 2 applies – Full pipe meters larger than 600 millimetres only Section 2.0 and Section 3.0
<b>Ongoing (revalidation) or Faulty meter (maintenance) – existing meter installation – new FPI Mag sensor and no new converter</b>	Section 2.0 and Section 3.0
<b>Ongoing (revalidation) or Faulty meter (maintenance) – existing meter installation – new converter and no new FPI Mag sensor</b> <b>Ongoing (revalidation) or Faulty meter (maintenance) – existing meter installation – no new FPI Mag sensor and no new converter</b>	Section 2.0

## 1.0 Key terms

Term	Definition
<b>Converter</b>	The logger/brains of the FPI Mag.
<b>FPI Mag</b>	The convertor and the FPI Mag Sensor
<b>FPI Mag Sensor</b>	Full profile insertion, multi-point electromagnetic sensor

## 2.0 Authorised Meter Validator

From 1 December 2022, an authorised meter validator must have completed training with McCROMETER for the FPI Mag, within the previous 2 years to perform the activities in the following table. The training record/certificate must be provided with the validation certificate where a new FPI Mag sensor is installed. This training is essential to achieve the uncertainties published by McCROMETER.

<b>Requirements for</b>	<b>CMI</b>	<b>Training by McCROMETER</b>
<b>Fit-for-purpose use</b>	✓	✓
<b>Diameter measurement and sizing of FPI Mag Sensor</b>	✓	✓
<b>Upstream and downstream lengths</b>	✓	✓
<b>FPI Mag installation</b>	✓	✓
<b>Power supply</b>	✓	✓
<b>System calibration</b>	✓	✓
<b>Configuration – user defined parameters</b>	✓	✓
<b>Data output</b>	✓	✓
<b>Maintenance</b>	✓	✓

### 3.0 Measurement assurance requirement B

The installation of the FPI Mag sensor must be in accordance with McCROMETER procedures and must be completed by CMI's trained by McCROMETER.

To ensure uncertainty specifications published by McCROMETER are met, the following attributes must be determined according to McCROMETER procedures:

- diameter measurement
- sizing of FPI Mag sensor
- installation.

Confirmation that these attributes above have been determined in accordance with McCROMETER procedures, must be provided with the validation certificate. For example, provision of training record/certificate issued by McCROMETER (within the previous 2 years).

# NMI14/3/24 MAG5100W with MAG8000 Transmitter

The NMI/14/3/24 are self-contained meters for the measurement of water flow in a full pipe.

The following requirements do not replace the Siemens Sitrans MAG 5100W Operating Instructions, the Siemens Sitrans MAG 8000 Operating Instructions, or the National Measurement Institute Certificate of Approval NMI 14/3/24. The certificate and operating instructions are essential for the successful operation and maintenance of this device and must always be used.

However, for use of this meter under this module of the standard the following requirements must be met, as a minimum, and have been formulated from recommendations/advice in manufacturer literature and where required with input from the manufacturer.

Requirements to be confirmed by validation type	
Post-installation (new or replacement meter)	Section 2.0, Section 3.0, Section 4.0, and Section 6.0
Ongoing (revalidation) or Faulty meter (maintenance)	Section 2.0, Section 3.0, Section 4.0, Section 5.0, and Section 6.0

## 1.0 Key terms

Term	Definition
<b>MAG5100W</b>	The flow sensor which generates an electromagnetic field which the water passes through.
<b>MAG8000</b>	The transmitter/logger/brains of the device which operates a magnetic field in the MAG5100W (flow sensor), interprets the signal from the sensor and calculates the volume of water passing through the meter. This term includes the MAG8000CT.
<b>NMI14/3/24</b>	A self-contained water meter with a MAG8000 (including the MAG8000CT) transmitter and the MAG5100W (flow sensor).

## 2.0 Installation

The meter has several options available for power supply. Internal battery, externally mounted battery, or external power supply.

Where an external power supply is used to power the device, an internal battery backup must be used.

## 3.0 Configuration

Alarms for the following faults must be activated (switched on).

Alarm	Description
<b>Insulation</b>	An insulation fault with the coil current and the electrodes reading each other.
<b>Coil current</b>	An error in the coil e.g., the coils have been disconnected.
<b>Amplifier overload</b>	Instability in the electrode circuit e.g., the electrode(s) have been disconnected.
<b>Checksum</b>	Checksum test shows corrupted or invalid data. May indicate a failed printed circuit board or a damaged/defective transmitter.
<b>Lower power / low battery</b>	Battery capacity is below pre-set threshold.

## 4.0 Output

Where the department requires meter health as an output from the meter:

Where not already incorporated into the NMI14/3/24, a serial communication module must be added to the meter. To have a validation certificate issued, where the meter:

- is installed after this document came into effect - it must have a serial communication module installed as part of validation post-installation
- was installed prior to the effect of this document - it must have a serial communication module installed as part of the next process of validation for the meter.

The serial communication module provides serial output (allows the notification of alarms e.g., low battery) from the meter for interface with third party transmission devices.

Where the department requires pulse output only:

The NMI14/3/24 must have the pulse output connection in place, which registers a pulse each time a set volume of water passes through the meter. To have a validation certificate issued, where the meter:

- is installed after this document came into effect - it must have the pulse output connection in place and configured as part of the process of validation, post-installation
- was installed prior to the effect of this document - it must have a pulse output connection in place and configured as part of the process of ongoing validation (revalidation) of the meter.

The pulse output connection allows the meter to interface with third party transmission devices.

## 5.0 Maintenance

Where an internal battery is used to power the device:

- The internal battery must be replaced at a 5-year interval, irrespective of remaining battery life.

When an internal battery is replaced:

- A new Silica gel bag must be added on top of the battery pack, with the old bag disposed of.
- A new O-ring must be used, with the old O-ring disposed of. Smear O-ring with acid-free lubricating gel.
- Reset battery operating time and remaining capacity.

Where an external battery is used to power the device:

- The external battery must be replaced at a 10-year interval, irrespective of remaining battery life.

When an external battery is replaced:

- Reset battery operating time and remaining capacity.

Where an external power supply is used to power the device:

- The backup battery must be replaced at a 5-year interval, irrespective of remaining battery life.

# SIEMENS SONO - modular metering system

The SONOKIT8000 is a modular metering system for the measurement of water flow in full pipe.

The following requirements do not replace the Siemens Sitrans F SONOKIT8000 User Manual and including the Siemens Sitrans FUS080 transmitter Operating Instructions. The user manual and operating instructions are essential for the successful installation, operation and maintenance of this device and must always be used.

However, for use of this meter under this module of the standard the following requirements must be met, as a minimum, and have been formulated from recommendations/advice in manufacturer literature and where required with input from the manufacturer.

Requirements to be confirmed by validation type	
<b>Post-installation – new meter installation</b>  <b>Existing meter installation – new FUS080 and new transducers installed</b>	Table 2 applies – Full pipe meters larger than 600 millimetres only.  Section 2.0, Section 3.0, Section 4.0, Section 5.0, Section 6.0, Section 7.0, Section 8.0, Section 9.0, Section 10.0, and Section 12.0
<b>Ongoing (revalidation) or Faulty meter (maintenance) – existing meter installation - new transducers only installed and no new FUS080</b>	Section 2.0, Section 3.0, Section 4.0, Section 5.0, Section 6.0, Section 7.0, and Section 9.0
<b>Ongoing (revalidation) or Faulty meter (maintenance) – existing meter installation – no new transducers and new FUS080 installed</b>  <b>Ongoing (revalidation) or Faulty meter (maintenance) – existing meter installation – no new transducers and no new FUS080</b>	Section 4.0, Section 5.0, Section 6.0, Section 7.0, Section 8.0, and Section 9.0

## 1.0 Key terms

Term	Definition
<b>FUS080</b>	The transmitter/logger/brains of the SONOKIT8000.
<b>SONOKIT8000</b>	The transmitter/logger/brains of the device (FUS080) operate the transducers, measures the travel times between the transducers and calculates the volume of water passing through the meter. It is a modular metering system.
<b>Transducers</b>	Retrofit acoustic transducers in pipes.

## 2.0 Authorised Meter Validator

From 1 December 2022, a CMI must have completed training by SIEMENS for the SONOKIT8000 within the previous 2 years to perform the activities in the following table. The training record/certificate must be provided with the validation certificate where new transducers are installed.

Activity	CMI	Training by SIEMENS
Installation of new transducers	✓	✓
New transducer position uncertainty	✓	✓
New transducer calibration using the SONOKIT8000 Calibration Software	✓	✓

### 3.0 Measurement assurance requirement B

With the installation of new acoustic transducers:

- The sensor-pipe-data and transducer-position must be determined with the uncertainty specified in the user manual and calibration must be completed using the calibration software of the SONOKIT8000.
- Confirmation of attainment of this uncertainty must be demonstrated and submitted with the validation certificate for the meter installation. For example, provision of training record/certificate from SIEMENS (within the previous 2 years).
- A SIEMENS ‘Site Acceptance Form’ (or newer SIEMENS iteration) must be provided with the validation certificate for the meter installation.

### 4.0 Fit for purpose

The SONOKIT8000 must not be used to measure velocities more than 10 metres per second.

The SONOKIT8000 must be used in pipes 48” in diameter, or smaller.

### 5.0 Installation

The meter has two options available for power supply - internal battery or external power supply.

Where an external power supply is used to power the device, the internal battery backup must be used.

For the respective installation scenarios, the meter must be installed in a straight uniform pipe and with the upstream and downstream lengths specified following (as a minimum):

- No flow disturbance scenario – 10x pipe diameters upstream and 3x pipe diameters downstream
- Reduced pipe scenario – 10x pipe diameters upstream and 3x pipe diameters downstream
- Expanded pipe scenario – 20x pipe diameters upstream and 3x pipe diameters downstream
- Pump causing spiral flow scenario – 40x pipe diameters upstream and 3x pipe diameters downstream
- Two elbows in plane scenario – 20x pipe diameters upstream and 3x pipe diameters downstream
- Two elbows out of plan scenario – 40x pipe diameters upstream and 3x pipe diameters downstream

Must only be used in a full pipe while measuring.

Cables between the transducers and the FUS080 must be enclosed in electrical conduit.

## 6.0 Configuration

Alarms for the following faults must be activated (switched on):

Fault type	Description
F 1	No water in contact with transducer 1A or 1B or transducers defective
F 2	No water in contact with transducers 2A or 2B or transducers defective
F 3 & F 4	Internal software fault – contact Siemens
F 5	Battery capacity is below pre-set threshold
F 9	Datalogger warning/alarm

## 7.0 Output

Where the department requires meter health as an output from the meter:

Where not already incorporated into the FUS80, a serial communication module must be added to the meter. To have a validation certificate issued, where the meter:

- Is installed after this document came into effect - it must have a serial communication module installed as part of validation post-installation.
- Was installed prior to the effect of this document - it must have a serial communication module installed as part of the next process of validation for the meter.

The serial communication module provides serial output (allows the notification of alarms e.g., low battery) from the meter for interface with third party transmission devices.

Where a serial communication module is installed, an external power supply must be used.

Where the department requires pulse output only:

The FUS80 must have the pulse output connection in place, which registers a pulse each time a set volume of water passes through the meter. To have a validation certificate issued, where the meter:

- Is installed after this document came into effect - it must have the pulse output connection in place and configured as part of the process of validation, post-installation.
- Was installed prior to the effect of this document - it must have a pulse output connection in place and configured as part of the process of ongoing validation (revalidation) of the meter.

The pulse output connection allows the meter to interface with third party transmission devices.

## 8.0 Maintenance

Where an internal battery is used to power the device - the internal battery must be replaced at a 5-year interval, irrespective of remaining battery life.

When an internal battery is replaced - reset battery operating time and remaining capacity.

Where an external power supply is used to power the device - the backup battery must be replaced at a 5-year interval, irrespective of remaining battery life.



# SIEMENS SONO – self-contained

The SONO–self-contained is a self-contained meter for the measurement of water flow in full pipe.

The following requirements do not replace the Handbook. The Handbook is essential for the successful installation, operation and maintenance of this device and must always be used.

However, for use of this meter under this module of the standard the following requirements must be met, as a minimum, and have been formulated from recommendations/advice in manufacturer literature and where required with input from the manufacturer.

Requirements to be confirmed by validation type	
<b>Existing meter installation – new controller and new transducers installed into existing factory pipe spool</b>	Section 2.0, Section 3.0, Section 4.0, Section 5.0, Section 6.0, Section 7.0, and Section 8.0
<b>Ongoing (revalidation) or Faulty meter (maintenance) – existing meter installation - new transducers installed into existing factory pipe spool and no new FUS080</b>	Section 2.0, Section 3.0, Section 4.0, Section 5.0, Section 6.0, Section 7.0, and Section 8.0
<b>Ongoing (revalidation) or Faulty meter (maintenance) – existing meter installation – no new transducers and new FUS080 installed</b>  <b>Ongoing (revalidation) or Faulty meter (maintenance) - existing meter installation – no new transducers and no new FUS080</b>	Section 4.0, Section 5.0, Section 6.0, Section 7.0, and Section 8.0

## 1.0 Key terms

Term	Definition
<b>FUS080</b>	The transmitter/logger/brains of the SONO-self-contained.
<b>SONO-self-contained</b>	The transmitter/logger/brains of the device (FUS080) operate the transducers installed in the factory pipe spool, measures the travel times between the transducers and calculates the volume of water passing through the meter. It is a self-contained meter.
<b>Transducers</b>	Accoustic transducers installed in factory pipe spool.

## 2.0 Authorised Meter Validator

From 1 December 2022, a CMI must have completed training by SIEMENS for the SONO-self-contained within the previous 2 years to perform the activities in the following table. The training record/certificate must be provided with the validation certificate where new transducers are installed.

Activity	CMI	Training by SIEMENS
<b>Installation of new transducers</b>	✓	✓
<b>New transducer position uncertainty</b>	✓	✓
<b>Calibration – post installation of new transducers</b>	✓	✓

## 3.0 Measurement Assurance Requirement B

With the installation of new acoustic transducers into the factory pipe spool:

- The sensor-data and transducer-position and calibration must be determined in accordance with SIEMENS procedures.
- Confirmation of attainment of the manufacturer's uncertainty must be demonstrated and submitted with the validation for the meter installation. For example, provision of training certificate from SIEMENS (within the previous 2 years).

## 4.0 Fit for purpose

The SONO-self-contained must not be used to measure velocities more than 10 metres per second.

## 5.0 Installation

The meter has two options available for power supply - internal battery or external power supply.

Where an external power supply is used to power the device, the internal battery backup must be used.

For the respective installation scenarios, the meter must be installed in a straight uniform pipe and with the upstream and downstream lengths specified following (as a minimum):

- No flow disturbance scenario – 10x pipe diameters upstream and 3x pipe diameters downstream.
- Reduced pipe scenario – 10x pipe diameters upstream and 3x pipe diameters downstream.
- Expanded pipe scenario – 20x pipe diameters upstream and 3x pipe diameters downstream.
- Pump causing spiral flow scenario – 40x pipe diameters upstream and 3x pipe diameters downstream.
- Two elbows in plane scenario – 20x pipe diameters upstream and 3x pipe diameters downstream.
- Two elbows out of plan scenario – 40x pipe diameters upstream and 3x pipe diameters downstream.

Must only be used in a full pipe while measuring.

Cables between the transducers and the FUS080 must be enclosed in electrical conduit.

## 6.0 Configuration

Alarms for the following faults must be activated (switched on):

- no water in contact with transducers or transducers defective
- internal software fault – contact SIEMENS
- battery capacity is below pre-set threshold
- datalogger warning/alarm.

## 7.0 Output

Where the department requires meter health as an output from the meter:

Where not already incorporated into the FUS80, a serial communication module must be added to the meter. To have a validation certificate issued, where the meter:

- Is installed after this document came into effect - it must have a serial communication module installed as part of validation post-installation.
- Was installed prior to the effect of this document - it must have a serial communication module installed as part of the next process of validation for the meter.

The serial communication module provides serial output (allows the notification of alarms e.g., low battery) from the meter for interface with third party transmission devices.

Version 3.02 last updated on 05/09/2022

Where a serial communication module is installed, an external power supply must be used.

Where the department requires pulse output only:

The FUS080 must have the pulse output connection in place, which registers a pulse each time a set volume of water passes through the meter. To have a validation certificate issued, where the meter:

- Is installed after this document came into effect - it must have the pulse output connection in place and configured as part of the process of validation, post-installation.
- Was installed prior to the effect of this document - it must have a pulse output connection in place and configured as part of the process of ongoing validation (revalidation) of the meter.

The pulse output connection allows the meter to interface with third party transmission devices.

## 8.0 Maintenance

Where an internal battery is used to power the device - the internal battery must be replaced at a 5-year interval, irrespective of remaining battery life.

When an internal battery is replaced - reset battery operating time and remaining capacity.

Where an external power supply is used to power the device - the backup battery must be replaced at a 5-year interval, irrespective of remaining battery life.

# SonTek – side-looking water meter

The SonTek side looking water meter is a modular metering system for the measurement of water flow in an open channel.

The following requirements do not replace the *Argonaut-SL System Manual*. The manual is essential for the successful installation, commissioning, operation, and maintenance of these devices, and must always be used.

However, for use of these meters under this module of the standard the following requirements must be met, as a minimum, and have been formulated from:

- Recommendations/advice in the manual and where required with input from the manufacturer.
- The USGS Computing Discharge Using the Index Velocity Method – Techniques and Methods 3-A23 report.

Requirements to be confirmed by validation type	
<b>Post-installation (new meter installation)</b> <b>Existing meter installation – new SL unit</b>	Section 2.0, Section 3.0, Section 4.0, Section 5.0, Section 6.0, Section 9.0
<b>Ongoing (revalidation) or Faulty meter – existing meter installation</b>	Section 2.0, Section 3.0, Section 4.0, Section 6.0, Section 7.0, and Section 8.0, Section 9.0

## 1.0 Key terms

Term	Definition
<b>ADCP</b>	An acoustic Doppler current profiler.
<b>AOC</b>	An Analog Output convertor for the SL.
<b>CPH</b>	An Australian Hydrographers Association, Certified Practicing Hydrographer. A list can be found here: Certified Professionals - Australian Hydrographers Association <aha.net.au>.
<b>CPH<sub>M</sub></b>	A CPH that has also completed the Meter Installation and Validation course run by Irrigation Australia Ltd (IAL) and is also qualified as a Certified Meter Installer and Validator.
<b>Measurement volume</b>	The volume of the horizontal layer of the water flow where the SL measures velocity.
<b>MIM</b>	The Modbus Interface Module for the SL.
<b>SL</b>	The SonTek side-looking water meter.
<b>USGS 3-A23</b>	The USGS Computing Discharge Using the Index Velocity Method – Techniques and Methods 3-A23 report.

## 2.0 Authorised Meter Validator

Until 1 December 2022, the relevant person must:

- engage<sup>#</sup> a CPH
- nominate their CPH for appointment by the chief executive as an authorised meter validator under s109 of the Water Regulation, for their SL.

<sup>#</sup>The CPH is engaged to complete corrective and preventive maintenance, calibration, and validation for their SL.

From 1 December 2022, the relevant person must

- engage<sup>##</sup> a CPH<sub>M</sub>
- nominate their CPH<sub>M</sub> for appointment by the chief executive as an authorised meter validator under s109 of the Water Regulation, for their SL.

<sup>##</sup>The CPH<sub>M</sub> is engaged to complete corrective and preventive maintenance, calibration, and validation for their SL.

## 3.0 Fit for purpose requirements

An SL must operate within these basic requirements:

- Water velocity range:  $\pm 6$  m/s.
- Channel width: SL500 – 1.5 to 120m; SL1500 – 0.2 to 20m; SL3000 – 0.1 to 5m.
- Stage measurement: SL500 – 0.2 to 18m; SL1500 – 0.15 to 10m; SL3000 – 0.1 to 5m.

An SL must not be used in a water body where insufficient reflective particles are present, noting most natural environments usually have sufficient reflective particles suspended.

### 3.1 Flow

The SL must:

- be located away from intake or outlet structures and must be located away from the beginning or end of a culvert or pipe
- be in a straight section of channel, away from curves that can cause variations in the flow distribution
- be located away from any underwater structures or vegetation that can cause turbulence or changes in the flow distribution.

## 4.0 Installation requirements

No physical obstructions must be near or in the path of the two angled acoustic beams.

The X-axis of the SL must be parallel to the primary flow direction.

The SL mounting orientation must be repeatable – the mounting structure must return the SL to the exact position when the sensor is removed for maintenance or inspection.

The SL mounting must keep the instrument stable; it should not shift or move with time and be able to resist vibration.

The SL must be installed level. That is, the measurement plane formed by the two angled acoustic beams should be parallel to the water surface, ideally within 1-2 degrees.

### 4.1 Depth

The SL is usually installed at the mid-point of the vertical water column. Where there are large variations in water depth, the installation depth must be installed above mid-water depth at the lowest water level e.g., if water level varies from 3 to 5 metres, the SL might be installed 2m above the bottom, placing it 1 metre below the surface at low water, and 3 metres below the surface at high water.

### 4.2 Cable protection

Power and communications cables must be enclosed in a mechanical conduit where not enclosed in a mounting pole.

## 4.3 Power supply

The SL is powered from an external power supply:

- Where mains power is used, the design of the external power supply must ensure the device can continue operating for 72 hours without mains power available. This could be achieved with the use of a correctly sized external battery (or battery pack) as a back-up power supply, which is trickle charged from the mains supply.
- Where mains power is not available or not used, an external battery (or battery pack) must be used with charging of the battery by a solar panel. The external battery must be sized correctly to allow the device to continue operating for 7 days with no sun available to charge the battery. The battery must only require replacement after 5 years of operation, outside of premature cell failure.
- The cables from the solar panel to the device must be enclosed in electrical conduit when not enclosed in any mounting pole.
- The solar panel must have tri-spikes (or similar barrier mechanism) installed on the top of the solar panel to reduce the accumulation of bird droppings on the front face of the panel.
- The solar panel must be orientated to the North at the appropriate incline angle, and the panel must not be shaded by trees or structures

## 4.4 Flow Display

The SL must have a flow display attached, enabled, and mounted on the channel bank so that the display can be viewed and operated while extraction is occurring.

## 4.5 High-Temperature Environments

West of the Great Dividing Range or North of the Tropic of Capricorn (in Queensland), where the SL will be out of the water (while still operating) for extended periods, the device must have a shade structure manufactured and fitted over the device with a hole to allow operation of the stage transducer. The structure must shade the SL from the Sun without impacting the operation of the respective beams.

# 5.0 Measurement and assurance requirement B

After deployment of a new or replacement SL:

- A deployment report including the following parts, must be provided to the relevant person with a validation certificate (post-installation) by their CPH:
  - Site Selection (see Section 5.1 for requirements).
  - Standard Cross Section Establishment (see Section 5.2 for requirements).
  - Index Velocity (see Section 5.3 for requirements).
  - Configuration (see Section 5.4 for requirements).
- A deployment report that meets the requirements in this section is the calibration certificate for the SL, satisfying Measurement Assurance Requirement B) of this module of the standard.
- The relevant person must provide the deployment report for the new or replacement SL, with the validation certificate, to the department.

## 5.1 Site Selection

Prior to the installation of a new or replacement SL, the channel cross section must be measured and documented using ADCP measurements. ADCP measurements provide valuable information and can be used to evaluate the horizontal and vertical flow distribution and channel bathymetry at a potential SL site.

The ideal metering site should meet the following criteria:

- a. The SL measurement volume is in a region of relatively parallel and uniform flow lines, and all acoustic beams are measuring approximately the same water velocity at all flow heights.

- b. The SL measurement volume is in or near the region of maximum velocity and free from any boundary effects on flow.
- c. The general course of the stream is straight for the greater of about 90 metres or 5 to 10 channel widths upstream or downstream from the meter site.
- d. The SL is located a minimum of 5 to 10 channel widths upstream or downstream from any tributary inflows or flow control structure.
- e. The total flow is confined to one channel at all flow heights, and no flow bypasses the site as subsurface flow.
- f. The stream/channel bed is not subject to scour and fill and is generally free of aquatic growth.
- g. A satisfactory reach for measuring discharge at all flow heights is available within reasonable proximity of the meter site.
- h. The SL is easily accessible for installation, operation, and maintenance.
- i. Flow at the site is free from excessive air entrainment in the water column, such as might occur immediately downstream of a weir, dam, or control structure.

Typically, all these requirements cannot be met at any one site; however, when at all possible, uniform horizontal and vertical flow distributions, parallel flow lines, and a stable channel shape must take precedence with locating an SL. If this is the case, the site assessment enables the CPH to decide where in the cross section the SL should be located to best measure an index velocity. After a satisfactory cross section is located, the orientation, frequency, and location of the SL in the cross section must be chosen such that reliable and accurate index velocity measurement may be obtained from the site.

The deployment report must document the rationale for the site selected and provides helpful background information about the site and the establishment of the SL.

## 5.2 Standard Cross Section Establishment

A standard cross section must be established as close to the new or replacement SL as possible. The section must be perpendicular to the primary flow direction. The section must be marked so that subsequent surveys can be performed at the same location. The location will be used to monitor change in the section over time.

A stage-area rating must be established at the standard cross section, and surveying techniques involving tools such as a surveying level and stadia, depth soundings and a tagline, echo sounder and tagline, ADCP, or some combination thereof, may be used.

The survey/s will result in the collection of a continuous series of two values: the horizontal position from an established reference point (typically on top of the left channel bank, looking downstream) and the elevation associated with that position. The survey method/s for measuring horizontal and vertical position must be chosen to accurately define the shape of the channel.

The continuous survey series must then be used to compute the stage-area rating for the standard cross section. This rating provides the basis for the geometry uploaded to the SL.

The deployment report must document:

- the standard cross section chosen
- the methods used and data from the survey
- the approach to compute the stage-area rating.

Documenting the standard cross section establishment provides a starting point for analysis of change in the stage-area rating over time.

## 5.3 Velocity Equation

Where a theoretical velocity equation (only the 1/6-power law relationship must be used, with the location of the SL velocity cell relative to the channel geometry) is used, the SL must only be used with these regular channel geometries:

- concrete lined open channels

- concrete lined rectangular or trapezoidal culverts
- natural lined open channels with near-trapezoidal shape
- round and elliptical pipes.

Where an index velocity equation is used, the SL may be used with:

- natural streams with complicated cross-sectional geometry
- complicated flow structures.

The deployment report must explain the basis for use of:

- a theoretical equation; or
- an index velocity equation (see Section 7.1 for requirements).

## 5.4 Configuration

The deployment report must record the following parameters and where specified provide an explanation for the parameter used.

The maintenance report developed in Section 7.0, must also record the parameters in the following table and where specified provide an explanation of the parameter used.

Parameters	Notes
<b>Firmware version</b>	The CPH must confirm if there are firmware updates available as part of any activity, and the updates must be uploaded to the SL.  Prior to upgrading the firmware on an existing SL, the CPH must download the internal recorder of the SL. Where configuration and total volume information is lost because of the firmware upgrade it must be uploaded to the SL after the update is complete.
<b>Internal clock</b>	Deployment → date and time must be set to Australian Eastern Standard Time by synchronising the SL clock with an electronic device (e.g., computer). This is a record of this.  Maintenance → the date and time must be confirmed to be correct. This is a record of this.
<b>Internal recorder</b>	The internal recorder must be turned on (enabled).
<b>Averaging interval</b>	Settings of 300 to 900 seconds (5 to 15 minutes) are typical. Where a setting outside of this range is used, an explanation of why is required.
<b>Sampling interval</b>	Setting this interval equal to the averaging interval is typical. Where a different setting is used, an explanation of why is required.
<b>Cell Begin</b> <b>Cell End</b> <b>Coordinate System</b> <b>ReverseXVelocity</b>	Maintenance → where changes to these parameters are made an explanation of why must be provided.
<b>Temperature Mode</b>	This is usually set to 'measured'. Where it is not: <ul style="list-style-type: none"> <li>• provide an explanation of why</li> <li>• record the 'Default Water Temperature' used.</li> </ul>
<b>Default Water Salinity</b>	An explanation of the source for this setting is required.



<b>Profiling Mode</b>	An explanation of the selected mode must be provided. Where enabled, record the Blanking Distance, the Cell Size, and the Number of Cells.
<b>Channel Type</b>	This must be 'Irregular'.
<b>Geometry</b>	Deployment → see Section 5.2 for requirements.
<b>SL Elevation</b>	Maintenance → see Section 7.3 for requirements.
<b>Velocity Equation</b>	Deployment → see Section 5.3 for requirements. Maintenance → see Section 7.0 for requirements.
<b>Total Volume</b>	Must be enabled.
<b>Remember Total Volume</b>	This will typically be set to 'Continuous'. Where 'Initialise' is used, an explanation of why must be provided.
<b>Allow Volume Reset</b>	This must be set to 'No'.
<b>Total Volume Criteria</b>	Where the default setting of 'Disabled' is not used, an explanation of why must be provided.

## 6.0 Output

### Where the department requires meter health as an output from the meter:

The SL must have a MIM installed and operating. To have a validation certificate issued, where an SL:

- Is installed after this document came into effect - it must have a MIM installed as part of the process of validation, post-installation.
- Was installed prior to the effect of this document - it must have a MIM installed as part of the next process of validation.

The MIM provides output from the SL for interface with third party transmission devices.

### Where the department requires pulse output only:

The SL must have an AOC installed and operating, as a minimum. Noting: this requirement can also be satisfied using the meter health option above. To have a validation certificate issued, where an SL:

- Is installed after this document came into effect - it must have an AOC installed as part of the process of validation, post-installation.
- Was installed prior to the effect of this document - it must have an AOC installed as part of the next process of validation.

The AOC provides output from the SL for interface with third party transmission devices.

## 7.0 Periodic calibration

After each interval of maintenance in this section is complete for an SL.

- A calibration report including the following parts, must be provided to the relevant person by their CPH:
  - index velocity calibration (see Section 7.1 for requirements) or Index velocity remeasurement (see Section 7.2 for requirements). This includes standard cross section remeasurement (see Section 7.3 for requirements)
  - analysis of the Internal Recorder download (see Section 7.4 for requirements); and Record-of and explanation-for the configuration parameters now used in for the SL (see Section 5.4 for requirements).

To set some expectation around the provision of the calibration report by the CPH to the relevant person, within 28 business days of the internal recorder download would be appropriate.

The calibration reports conforming to the requirements in this section is the calibration certificate for the SL, satisfying Measurement Assurance Requirement E of this module of the standard.

The relevant person must provide the calibration report/s received since the last process of validation for the SL, with the next validation certificate, to the department.

## 7.1 Index Velocity Calibration

Commencing 1 December 2022, where a theoretical velocity equation is used for an SL, 'index velocity calibration' must be completed at the following interval as a minimum. A CPH will often refer to this activity as index velocity rating development, but for this document we will use calibration.

For this circumstance the relevant person must engage their CPH to undertake calibration on the SL until an index velocity equation of sufficient quality has been developed and is used in the configuration of the SL. The index velocity equation is an empirical relation developed by making several independent discharge measurements using ADCP in a variety of flow and stage conditions, while measuring velocity with the SL.

### 7.1.1 Interval

'Index velocity calibration' must be undertaken during any single extraction event by the relevant person within this 12-month period – 1 December to 30 November (where extraction occurs during this period). More frequent calibration can be undertaken, this is a minimum requirement. Calibration does not need to occur for the duration of the extraction event, the CPH should time the calibration opportunity to expedite the development of the index velocity equation only.

### 7.1.2 Report

Each calibration event in the development of the index velocity equation must be thoroughly documented to show what steps were taken and what logic was used to develop and choose a particular index velocity equation for use in the configuration for the SL. Each new calibration event will build on earlier calibration events. This part of the calibration report must provide analysis:

- on the quality of the index velocity equation at the completion of this latest calibration event, and consider the data and analysis from any earlier calibration events for the SL
- of the standard cross section (see Section 7.3 for requirements).

USGS 3-A23 provides the method and approach which must be used for compiling and analysing data, and the development of a quality index velocity equation.

Where an index velocity equation of sufficient quality is developed, this will be confirmed in the report and the equation must be used in the configuration for the SL (see Section 5.4 for requirements).

In some situations, the index velocity equation may take several calibration events to develop.

## 7.2 Index Velocity Remeasurement

Commencing 1 December 2022, where an index velocity equation is used for an SL, 'index velocity remeasurement' must be completed at the interval below. A CPH will often refer to this activity as index velocity rating validation, but for this document we will use remeasurement.

For this circumstance the relevant person must engage their CPH to undertake remeasurement on the SL using ADCP, to maintain the index velocity equation for the SL.

Remeasurement is just an extension of the calibration under Section 7.1 above, with each new event building on earlier remeasurement and/or calibration events.

### 7.2.1 Interval

'Index velocity remeasurement' must be undertaken at the interval in the following table and subject to the requirements shown. More frequent remeasurement can be undertaken, this is a minimum requirement. Remeasurement does not need to occur for the duration of the extraction event, the CPH should time the remeasurement opportunity to maintain the index velocity equation only.

Interval	Trigger for interval change
<p><b>During any single extraction event by the relevant person within the 12-month period – 1 December to 30 November (where extraction occurs during this period).</b></p>	<p>Where no change is required to the index velocity equation for 3 consecutive remeasurement events, the interval changes to 36 months (see next row).</p> <p>Where there is a change to the index velocity equation, remeasurement must continue at this 12-month period until no change is required to the index velocity equation for 3 consecutive remeasurement events, the interval then changes to 36 months (see next row).</p>
<p><b>During any single extraction event by the relevant person within the next 36-month period commencing 1 December (where extraction occurs during this period) – recurring.</b></p>	

### 7.2.2 Report

Each remeasurement event to maintain the index velocity equation must be thoroughly documented to show what steps were taken and what logic was used to maintain the equation in the configuration for the SL. This may involve no change to the equation, but a report must still be provided.

This part of the calibration report must provide analysis:

- on the quality of the index velocity equation at the completion of this latest remeasurement event, considering the data and analysis from any earlier remeasurement/calibration events for the SL
- of the standard cross section (see Section 7.3 for requirements).

USGS 3-A23 provides the method and approach which must be used for compiling and analysing data, and how to maintain the index velocity equation.

### 7.3 Standard Cross Section Remeasurement

Regarding the requirement for the establishment of a 'standard cross section' (see Section 5.2), remeasurement of the cross section must occur as part of the index velocity calibration (see Section 7.1) or remeasurement (see Section 7.2) event, above.

A stage-area rating must be developed for each velocity calibration (see Section 7.1) or remeasurement event (see Section 7.2), at the standard cross section. This part of the calibration report must include the stage-area rating developed:

- documenting the methods used and data from the survey
- the approach to compute the remeasured stage-area rating
- analysis of the remeasured rating
- documenting the reason for adopting the remeasured rating as a revised configuration parameter, or not.

Analysis to be provided in this part of the report:

- Does the standard cross section show a substantial change in shape?
- A comparison of the stage area ratings over the last 3 years, where available (e.g., deployment and remeasured), and do the ratings show substantial change?
- Has a change in the stage-area rating had an impact on the index velocity?

The CPH must also document the magnitude of the change and explain whether the stage-area rating has been revised as a configuration parameter, in this part of the report.

## 7.4 Download internal recorder, including analysis

As soon as possible after the finalisation of the extraction events used for Section 7.1 or 7.2 above, the relevant person must engage their CPH to:

- download the internal recorder
- undertake the following data analysis.

The internal recorder must not be downloaded during an extraction event by the relevant person.

The analysis in the following table must be completed and provided as a part of the calibration report. Importantly, the report must identify where data shows a feature which is 'of-concern' and must record the action taken to address these features where this is required. Where data is not available this will be noted in the report, with justification why. Examples of this analysis are in the SL System Manual.

<b>Data</b>	<b>Analysis</b>
<b>Velocity – plot</b>	Are velocity values realistic based on the deployment environment? Is the velocity data consistent with time?
<b>SNR – plot</b>	What are the typical SNR values? Are they high enough for reliable data? How much variation is seen in SNR values? Does the variation appear reasonable for real-world variations in water conditions? Was the SL out of the water at any time during the deployment? Is there any suggestion that the SL or a beam were blocked (e.g., vegetation or sand bank)?
<b>Stage – plot</b>	Does stage appear reasonable for the deployment environment? Are there periods when stage is not reported? Do these match periods when the SL was out of the water, or when something else interfered with stage measurements?
<b>Stage – view</b>	Check the Flow Datum loaded into the SL to ensure accurate channel geometry was entered.
<b>Stage and cross-sectional area – plot</b>	Is the calculated cross-sectional area reasonable based on changes in stage?
<b>Velocity, stage, and flow – plot</b>	Are calculated flow values reasonable based on changes in stage and flow velocity? Are flow values reasonable based on the deployment environment?
<b>Signal strength and noise level – plot</b>	Do changes in signal strength match changes in SNR? Is noise level constant to within 2-3 counts?
<b>Velocity and standard error of velocity – plot</b>	Does standard error of velocity values match predicted values? Do standard error of velocity values seem to match the sample-to-sample variation seen in the velocity data?
<b>Temperature, pressure, and battery voltage – plot</b>	Is temperature data reasonable for the deployment environment? Is pressure data reasonable for the deployment environment? Does pressure data show the same general variations as stage data Is battery voltage consistent with the power supply? Does the system have sufficient power for reliable operation?

Data	Analysis
<b>Internal diagnostic data – view</b>	<p>Is the signal strength profile reasonable for the environment?</p> <p>Do both beams show similar signal strength profiles?</p> <p>Are reflections from the opposite bank or underwater obstacles where you expect them?</p> <p>How does the signal strength profile compare to the theoretical decay curve?</p> <p>How does the signal strength profile change with time within the data file?</p>

## 8.0 Maintenance

### 8.1 Cleaning the Transducers

Periodic cleaning of the transducers may be needed to maintain optimal performance.

Carefully clean the transducers with a non-metallic brush.

### 8.2 O-rings and Desiccant pouch

The SL housing must only be opened by SonTek personnel. Where an SL is opened by SonTek, the O-rings and Desiccant pouch should be replaced.

### 8.3 Battery replacement

Noting the requirements of Section 4.3, after 5 years of operation and irrespective of perceived battery life, the following batteries must be replaced:

- Where mains power is used, the external battery (or battery pack) used as a back-up power supply.
- Where mains power is not available or not used, the external battery (or battery pack).
- The real-time Clock Back-up Battery.

## 9.0 Tamper-evident/preventive sealing

### 9.1 Mechanical tamper-evident sealing

#### 9.1.1 Deployed position

When the SL is in the deployed position for measurement, a mechanical tamper-evident seal must be applied to the mounting - the seal must be applied so that it must be broken to move the SL from the exact position for measurement.

# Appendix D – Meter installation plans

Note: The upstream/downstream diameter measurements are the minimum to be achieved.

Figure 5 - Meter installation plan for reduced pipe scenario

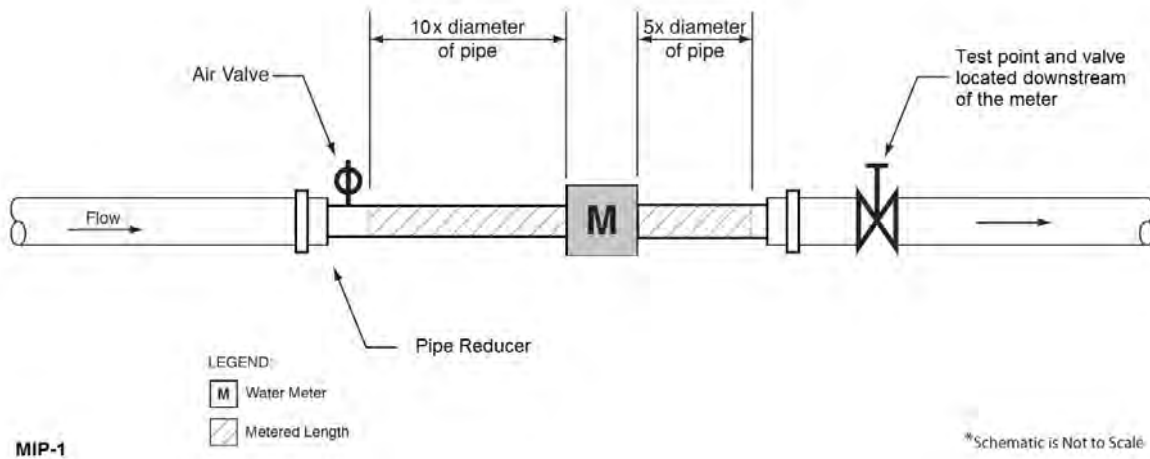

Figure 6 - Meter installation plan for expanded pipe scenario

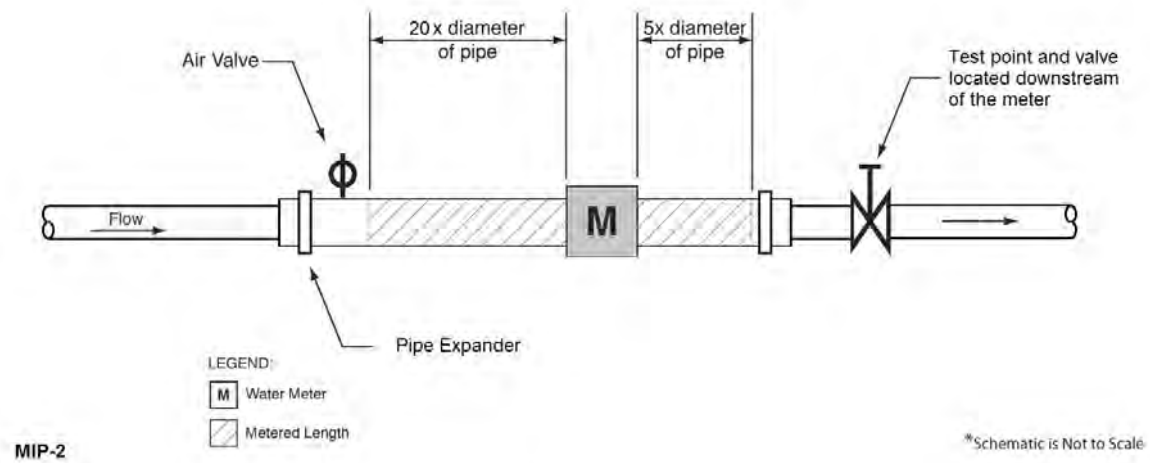

Figure 7 - Meter installation plan for pump causing spiral flow

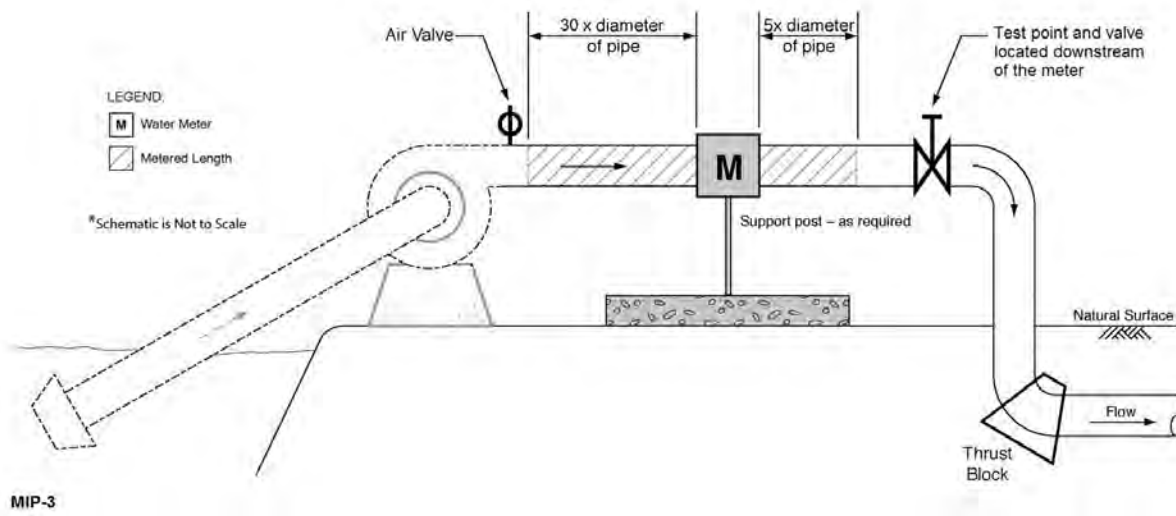

Figure 8 - Meter installation plan for two elbows, in plane

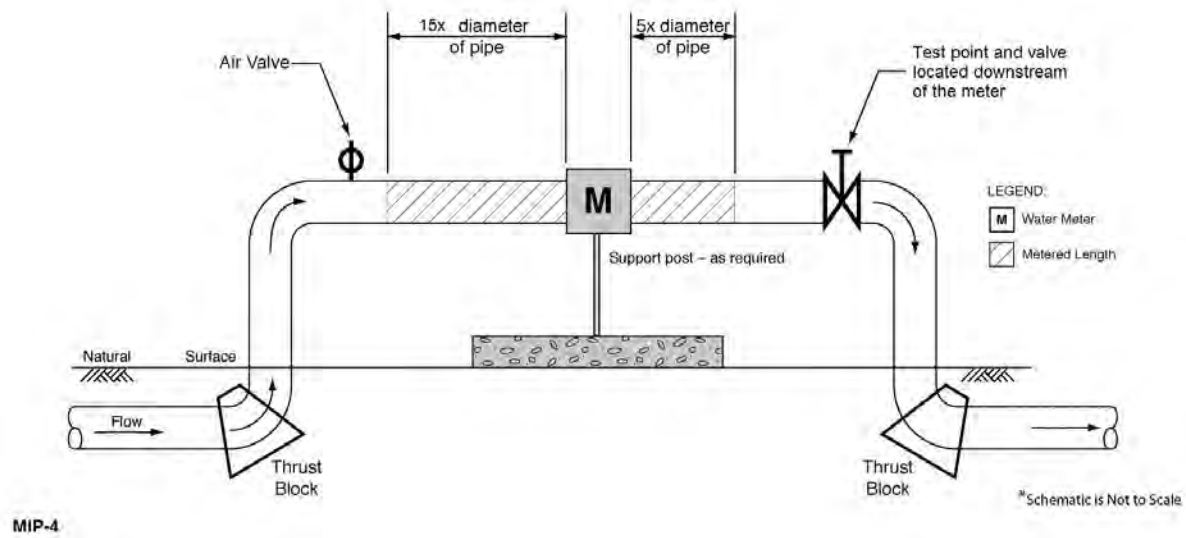

Figure 9 - Meter installation plan for two elbows, out of plane

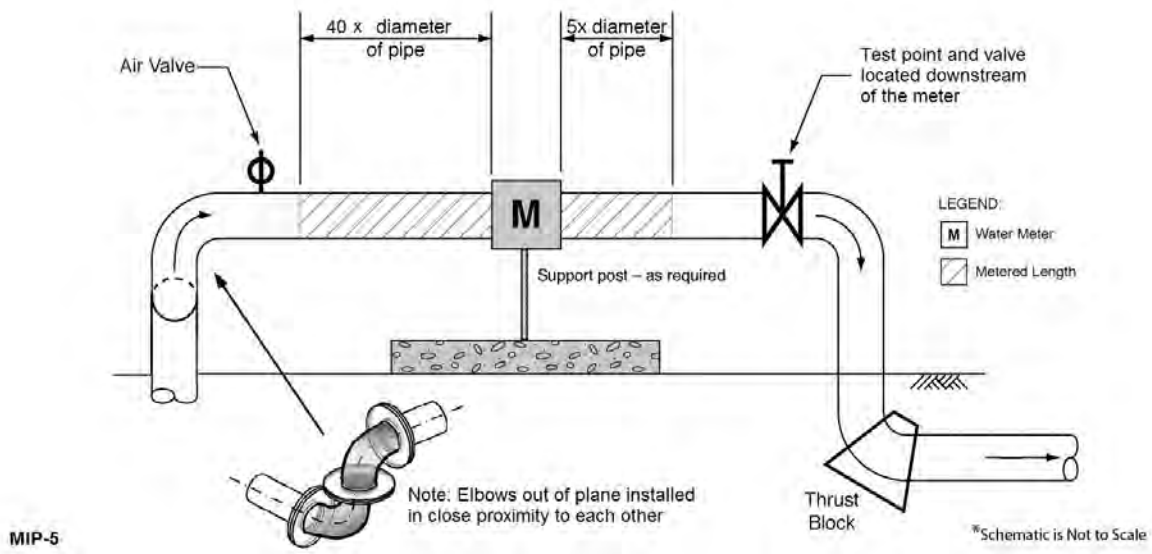
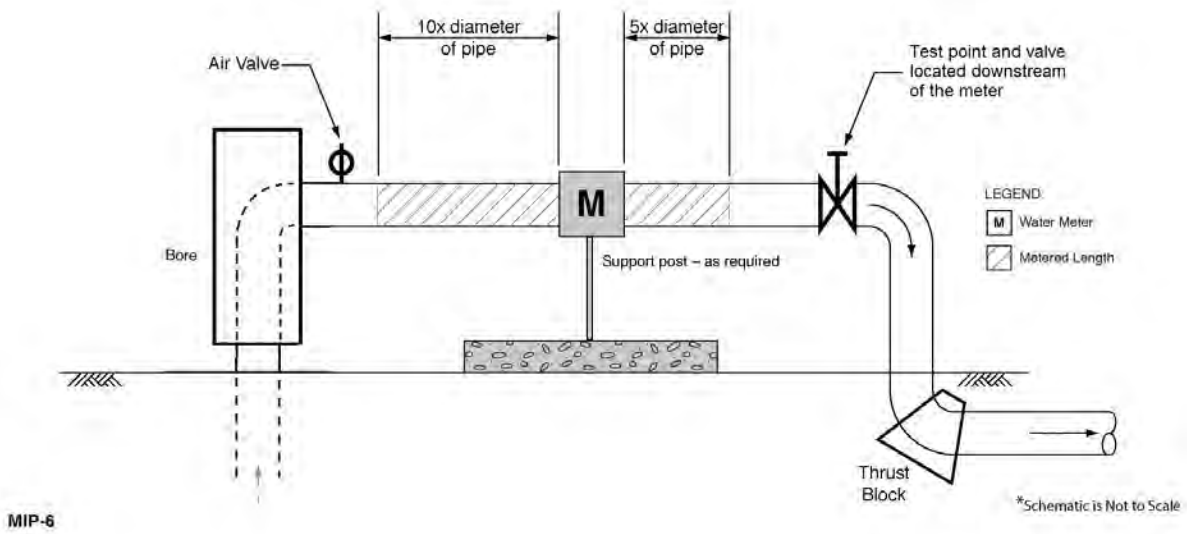

Figure 10 - Meter installation plan for underground water bore - pumped or artesian





## Module B – Water level stations

<b>1.0 Application</b>	<b>71</b>
1.1 Overland flow water measurement	71
<b>2.0 Output requirement</b>	<b>73</b>
<b>3.0 Measurement assurance requirements</b>	<b>73</b>
3.1 Which water level station can be used?	73
3.2 Data collection and transfer	74
3.3 Water level sensor	75
3.4 Site location and datums	76
3.5 Installation	77
<b>4.0 Maintenance</b>	<b>77</b>
<b>5.0 Validation</b>	<b>78</b>
5.1 Validation certificate	78
5.2 Tamper evident sealing	80
<b>6.0 Disclaimer</b>	<b>80</b>
<b>7.0 References and useful links</b>	<b>81</b>
<b>8.0 Further information</b>	<b>81</b>

### Appendices

<b>Appendix A – Glossary of terms</b>	<b>82</b>
---------------------------------------	-----------

### Tables

<b>Table 1 - Criteria to assess similar performance for existing water level stations</b>	<b>74</b>
---	-----------

### Figures

<b>Figure 1 - Elements of a water level station (typical)</b>	<b>72</b>
<b>Figure 2 - Elements of a water level station with third party data management</b>	<b>73</b>
<b>Figure 3 - Operating range of a typical water storage</b>	<b>75</b>
<b>Figure 4 - Location of pressure transducer type sensor</b>	<b>76</b>
<b>Figure 5 - Typical storage installation and datum location</b>	<b>76</b>
<b>Figure 6 - Datum examples</b>	<b>77</b>
<b>Figure 7 - Validation process</b>	<b>79</b>

# 1.0 Application

Module B (this module) of the standard applies where the measurement of water taken is dependent on, or includes, the measurement of water levels in relation to works water level stations and the Regulation prescribes a water entitlement to be a 'metered entitlement'.

## 1.1 Overland flow water measurement

Module B of the Queensland interim water meter standard for non-urban metering (this standard) details the performance requirements for existing and new water level stations. It applies to the specification and installation of devices used to collect storage water level data where required. This includes, but is not limited to, water licences that authorise the take of overland flow water and which are prescribed as metered entitlements in the Water Regulation 2016 (the Regulation).

The *Water Act 2000* (Water Act) requires that the holder of a metered entitlement must not take water other than through works that have an approved meter attached. This standard sets out the requirements necessary for water level measurement within a water storage. A water level station installed and capable of providing measured water level data for which a completed validation certificate has been supplied to the owner of the works and to the chief executive department, is consistent with the definition of approved meter under the Water Regulation 2016 (s106).

This standard is the first phase in a two-phase measurement and implementation process for measuring the take water using storage water level measurement. This standard (phase 1) outlines the installation of storage water level measurement stations and the transfer of measured data to the department. The second phase of this standard will build on storage water level measurement to create a modular metering system that can determine the volumes of water take using surveyed storage information and recognition of other influences to the measured storage height.

Metering the take of overland flow water is accomplished by employing a metering system to determine volumes taken under the water entitlement. A water level station installed in accordance with this standard, and used in conjunction with accurate information about the stage height-volume relationship of the storage, provides for the continuous measurement of volume in storage. Additional devices and techniques may also be used to account for the movement of water on a property. In this way, the system allows for the accurate determination of the volume of water taken under the water entitlement at a given time.

### 1.1.1 Phase 1

This standard provides the technical requirements measurement of the water level in storages and includes:

- water level sensor requirements
- components of a water level station
- location and installation requirements

Storage water level measurement to determine the volume of overland flow water taken requires continuous recorded data. Instantaneous measurement of storage water level can only provide a current stored volume. For this reason, data loggers are a mandatory component of water level stations as described in this standard.

### 1.1.2 Phase 2

Phase 2 of the measurement standard will outline how storage water level measurement data and other information can inform the determination of the volume of overland flow water taken. Other information required for phase 2 will include but is not limited to:

- survey and preparation of accurate storage height-volume relationships,
- additional recording devices and techniques
- water balance and accounting methods.

### 1.1.3 Water level station

A water level station is to measure and continuously record water level measurements accurately and be capable of storing and transferring recorded water level data. Water level station components include:

- a. the sensor and compatible processor to measure the water level (may sense pressure or proximity)
- b. communications equipment (for communication with data logger or data storage service)
- c. water level output logger
- d. reliable mounting fixtures
- e. power supply.

The installation and continuous function of all water level station components (a to e above) is required for it to be an approved meter (as per section 808 of the *Water Act 2000*).

Figure 1 and Figure 2 show the typical components of a water level station. Some installation and protective parts may not be shown in the diagrams.

**Figure 1 - Elements of a water level station (typical)**

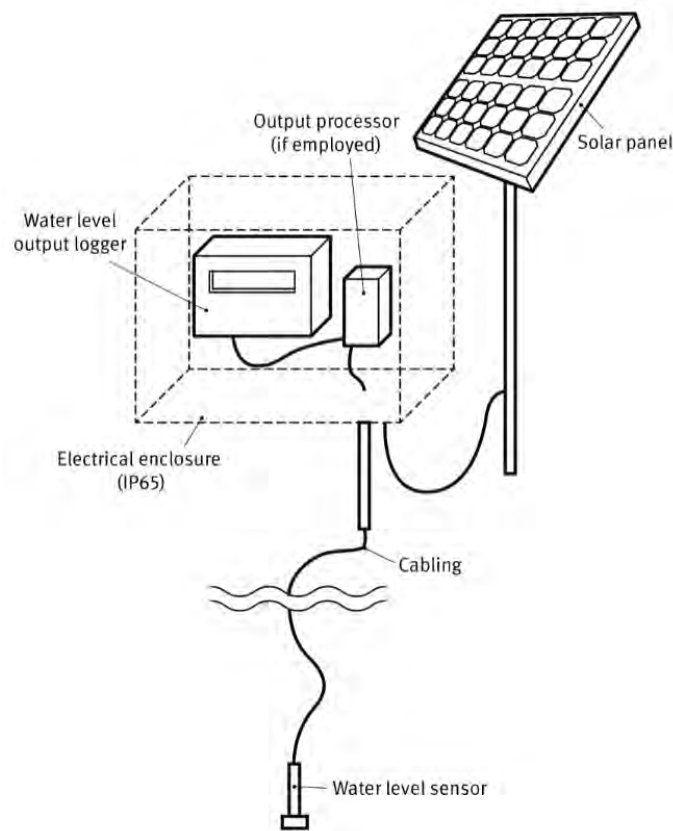
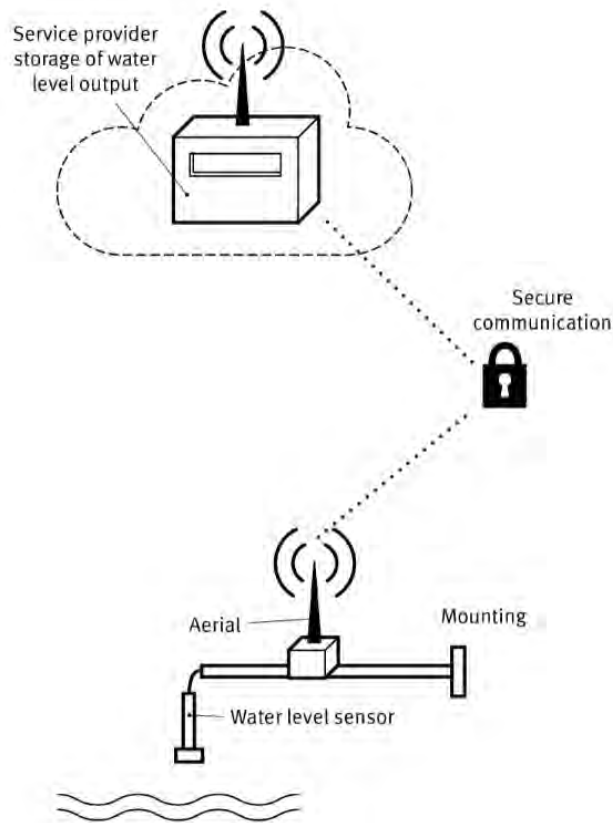

Figure 2 - Elements of a water level station with third party data management



## 2.0 Output requirement

The type of output and the storage of data is important to sound water management. The information being collected is water level information (which increases and decreases rather than accumulating). The department needs the time series record of water levels in storages for water management purposes. To allow this to happen, the water level records need to be stored for later access by the department. Refer to section 3.2.1 Increments and Display for more detail.

## 3.0 Measurement assurance requirements

Water level stations must, at a minimum, comply with the requirements outlined below.

A. A water level station specified in Section 3.1 must be used.
B. The data collection and transfer of the water level station must be in accordance with Section 3.2.
C. The water level sensor must meet the requirements in Section 3.3.
D. Site location and datums must be established as specified in Section 3.4.
E. The installation of the water level station must comply with Section 3.5.

### 3.1 Which water level station can be used?

#### 3.1.1 New water level stations

New water level stations are those which were installed on or after 31 December 2020.

### 3.1.2 Existing water level stations

Existing water level stations are those which were installed prior to 31 December 2020. Existing water level stations that meet this standard can continue to be used.

Existing water level stations that would not otherwise comply with specific requirements of this standard may be deemed to comply when similar performance can be demonstrated. The criteria for demonstrating similar performance for the specific requirements are described in Table 1 below.

**Table 1 - Criteria to assess similar performance for existing water level stations**

Requirement type	Similar performance
<b>For section 3.2 Recording events</b>	Existing water level stations equipped with water level data loggers that cannot be configured to record the events specified, are deemed to have similar performance if: <ul style="list-style-type: none"><li>it can be shown that the water level data logger has not been replaced on, or after, 31 December 2020.</li></ul>
<b>For section 3.3 Water level sensor</b>	Where an existing water level station cannot measure the complete operating range of the water storage to which it is installed due to the water level sensor being located above the dead storage level it may be deemed to have similar performance if: <ul style="list-style-type: none"><li>it is configured to measure the water level, from the level at which the sensor is installed, to the top of the storage operating range</li><li>its range of measurement allows the collection of information required to determine compliance against the associated water entitlement(s).</li></ul>

## 3.2 Data collection and transfer

### 3.2.1 Increments and display

The water level station must:

- record the water level in increments of not greater than 10 millimetres
- display and record the measurements in metric units (e.g. metres or millimetres).

### 3.2.2 Output and data logging

The water level station must:

- measure and record water level data at an interval of at least once each hour as an electronic output
- retain at least 5 years of continuous recorded data before overwriting
- retain recorded data if power or connection to another component is lost
- allow for stored data to be transferred by the department or a person appointed by the department under the Water Regulation 2016.

### 3.2.3 Recording events

A water level data logger must record a description of the event type, time and date for the following events:

- loss of power supply and reconnection of power supply
- occurrence of external access to the stored data or logger control system
- loss of communication and reinstatement of communication between the sensor and the logger
- sensor is disconnected and reconnected.

### 3.2.4 Data security

Where water level data is transmitted to, and stored by, a service provider, the service provider must:

- employ measures to ensure the transmission and storage of water level data is secure
- maintain the legal integrity of the data.

### 3.3 Water level sensor

The water level sensor must:

- be installed to provide water level measurements for the operating range of the storage
- have an accuracy for measurement of water level to  $\pm 10$  millimetres for any water level within the operating range of the storage
- for pressure transducer type (submerged) sensors – be installed to not be affected by silt or other types of sediment.

See Figure 3 which details the operating range for the storage and Figure 4 for a typical installation for a pressure transducer type sensor.

**Figure 3 - Operating range of a typical water storage**

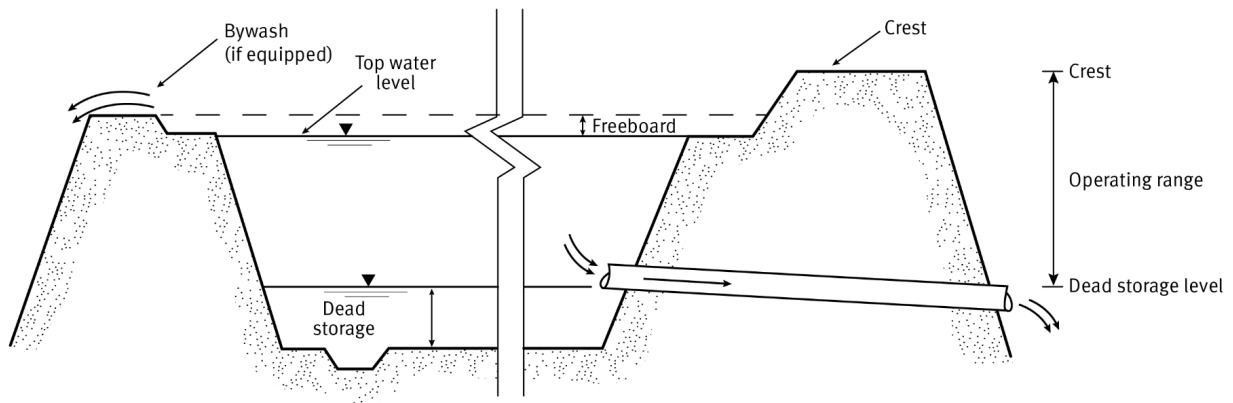
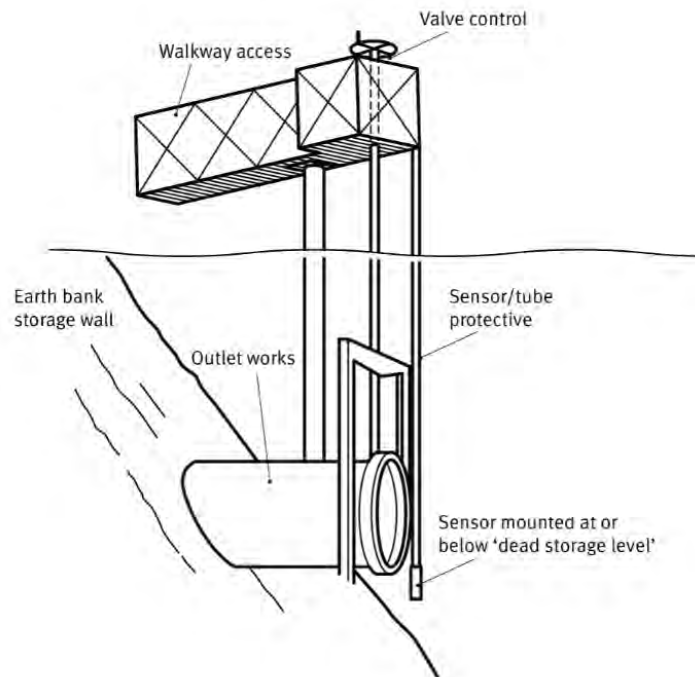

Figure 4 - Location of pressure transducer type sensor



### 3.4 Site location and datums

Datums provide a measured reference level for describing the elevation of all equipment installed at a site. Of particular importance when measuring water levels is the elevation of the water level sensor in relation to the datum and to operating range of the storage.

A typical location for the water level sensor, datum and associated equipment, where equipped, is a storage outlet pipe, gate structure and walk out as shown in Figure 5.

Figure 5 - Typical storage installation and datum location

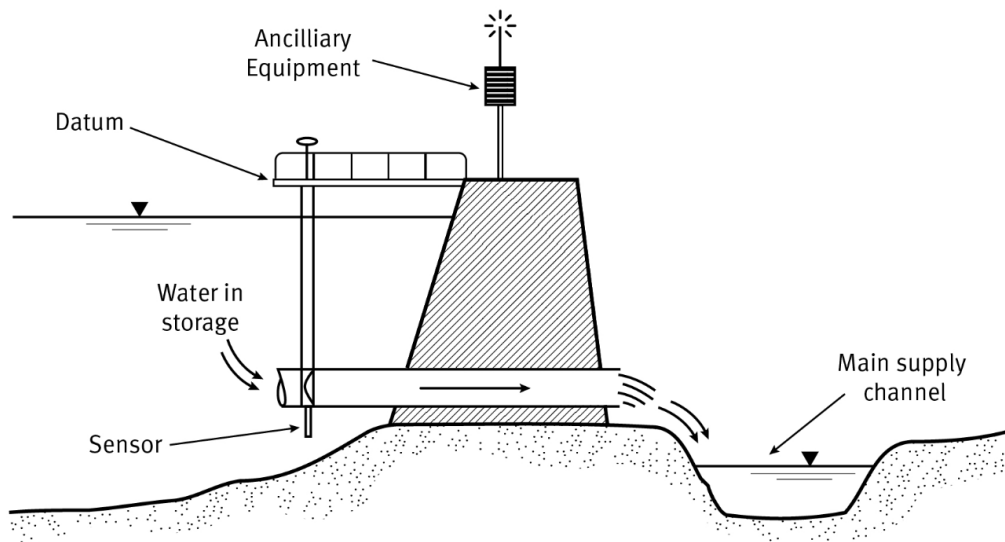

The datum should be in a location that can be easily and safely accessed. Typical datums could include a weld mark on, or a notch cut into, a permanent structure, such as a walk out, the headwall of a discharge pipe, or a deep bore casing.

Figure 6 shows three examples of datums that are about 10 x 50 millimetres in size.

Figure 6 - Datum examples

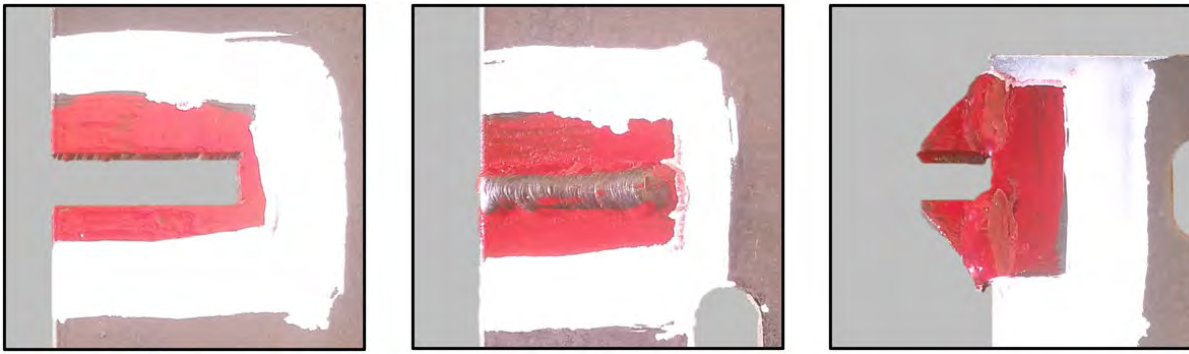

Subsequent amendments of this standard will introduce the second phase of requirements for datums and permanent survey marks which deal with:

- survey and preparation of accurate stage height-volume relationships
- configuration of additional devices and techniques
- preparation of water balance and accounting methods.

The water level station must have an associated datum that is:

- a. located close to the site at which the water level sensor is mounted
- b. located above the top water level for the storage
- c. located in a way that permits accurate comparison of the height of the water level sensor
- d. made from durable material such that it is not readily disturbed or destroyed
- e. not subject to movement
- f. distinguished from other marks in the vicinity with red and white markings.

## 3.5 Installation

### 3.5.1 Configuration and power supply

The water level station must be installed such that:

- a. connected to a continuous power supply
- b. each component is configured according to all relevant manufacturer specifications
- c. the measurement processor, data logger and connections to the measurement processor and data logger are contained within a sealed enclosure
- d. all components and enclosures are securely fixed and mounted
- e. is accessible.

### 3.5.2 Cabling

- a. All cables that connect to the sensor, components and power must be:
- b. continuous, or
- c. where joiners are used – must be within a sealed enclosure
- d. protected from damage by being contained within piping or conduit suited to local conditions.

## 4.0 Maintenance

Periodic maintenance is critical to the continued performance of a water level station. More frequent maintenance may be required if the metrological performance of the water level sensor is in doubt or affected by local conditions.



Minor maintenance work that is not likely to affect the metrological performance of the components of the water level station includes, but is not limited to:

- replacement of component parts
- cleaning external parts or removing debris or silt
- checking for signs of normal wear
- changing a battery.

Any minor maintenance should follow relevant work practices and/or maintenance plans.

## 5.0 Validation

### 5.1 Validation certificate

Where a water level station meets the requirements of this module of the standard, a validation certificate must be given to the relevant person within 20 business days of an inspection of a water level station by an authorised meter validator.

The relevant person must give a copy of the validation certificate to the Department within 20 business days of receipt of the validation certificate.

The Department validation form for this module is *W2F119B Water level station validation certificate*.

Figure 7 describes the process and actions that must be completed by an authorised meter validator when undertaking a process of validation.

Figure 7 - Validation process

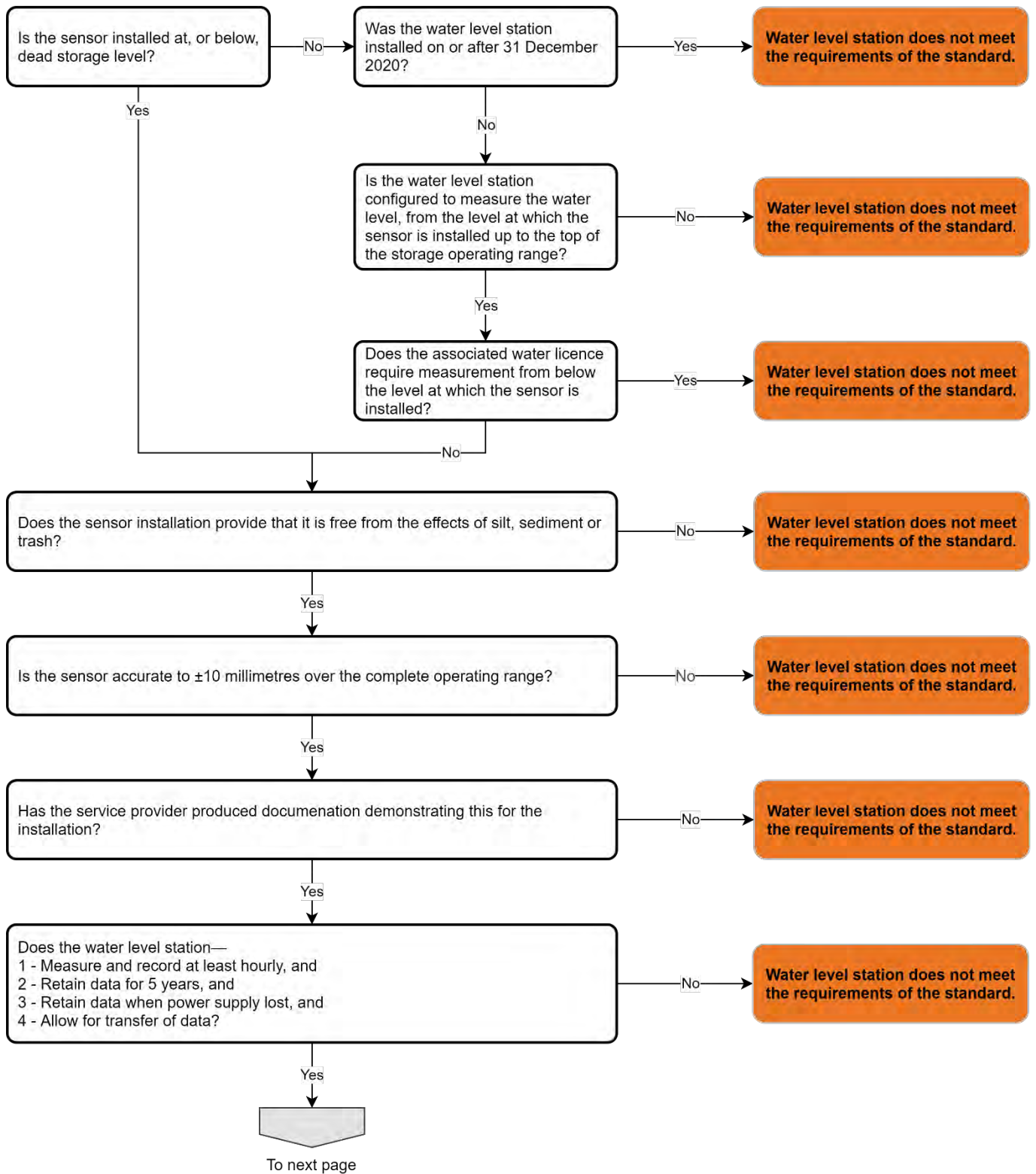

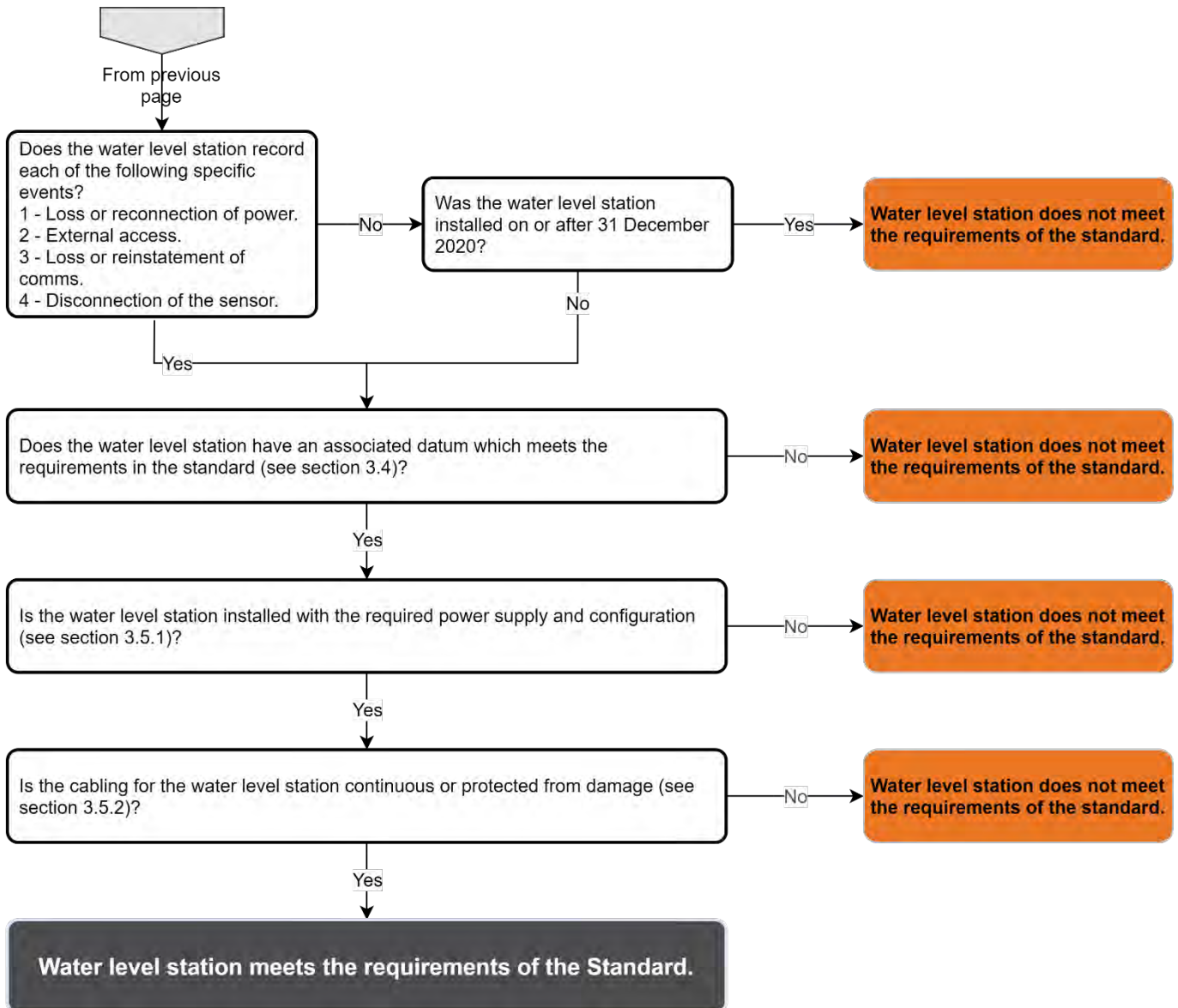

## 5.2 Tamper evident sealing

Tamper proof seals are used to protect the legal integrity of the water level measurement station.

Tamper proof seals must be used:

- a. to fix the water level sensor to the recorded installed sensor height
- b. to seal closed any enclosures.

Where tamper proof seals are broken (including during the course of undertaking maintenance), the water level station becomes a faulty meter under section 105 of the Water Regulation 2016 until an authorised meter validator installs new tamper proof seals.

## 6.0 Disclaimer

Nothing in this standard is intended to contradict the manufacturer's operating and installation directions that would void manufacturer's warranty or that would indirectly or directly result in loss or liability for which the department expressly disclaims responsibility.

## 7.0 References and useful links

Department Regional Development, Manufacturing and Water, 2019, *Queensland Non-urban Water Metering Policy for Unsupplemented Water Extractions 2019*, Queensland Government, Brisbane, 7 June 2021, <[https://www.dnrme.qld.gov.au/?a=109113:policy\\_registry/water-meter-non-urban-unsupp.pdf](https://www.dnrme.qld.gov.au/?a=109113:policy_registry/water-meter-non-urban-unsupp.pdf)>.

Irrigation Australia, 2021, 'Certified Meter Installer & Validator', Brisbane, viewed 7 June 2021, <<https://www.irrigationaustralia.com.au>> .

Murray-Darling Basin Authority, 2021, 'Compliance and enforcement documents', viewed 7 June 2021, <<https://www.mdba.gov.au>>.

### Legislation

*Water Act 2000* (Qld). Retrieved from <<https://www.legislation.qld.gov.au/view/pdf/inforce/current/act-2000-034>>.

Queensland Water Regulation 2016 (Qld) Retrieved from <<https://www.legislation.qld.gov.au/view/pdf/inforce/current/sl-2016-0216>>.

## 8.0 Further information

Further information on water metering is available on the Queensland Government website at <[www.business.qld.gov.au](http://www.business.qld.gov.au)> or call 13 QGOV (13 74 68).

# Appendix A – Glossary of terms

This glossary contains terms used in this standard.

<b>Term</b>	<b>Definition</b>
<b>Certified meter installer</b>	A person who is accredited by Irrigation Australia Limited as a meter installer (abbreviated to CMI).
<b>Continuous record</b>	For this standard, a continuous record is one where water level measurement is recorded at least once each hour.
<b>Existing water level stations</b>	Existing water level stations are those which were installed before 31 December 2020.
<b>Dead storage level</b>	The level at which water ceases to be able to be released from a storage. It may relate to gravity or pumped outlet works.
<b>Local conditions</b>	The physical environment and environmental conditions and influences at the installed device location. For a component to be suitable for use in local conditions, its longevity and operation would not be affected by extremes of the local environment such as temperature, rain, flooding, humidity, vibration, pests and vermin (insects, birds etc).
<b>Loss of power supply</b>	When the supply voltage for any component of a water level station drops below the minimum voltage required by the manufacturer.
<b>Operating range</b>	The range from the dead storage level to the level of the storage crest or the by-wash if equipped.
<b>Datum</b>	A datum is a mark established at the site of the water level station to allow referencing height of the water level sensor and recorded water levels.
<b>Works</b>	Infrastructure used in the taking or storage of overland flow water, including water storages, pumps and pipes, levees, channels, and surge areas. The works may also be used in the taking of water from a watercourse.

# Module C – Existing meters for surface water extraction using a small concrete rectangular weir measurement structure

<b>1.0 Application</b>	<b>84</b>
<b>2.0 Output requirement</b>	<b>84</b>
<b>3.0 Measurement assurance requirements</b>	<b>84</b>
3.1 Which meter can be used	85
3.2 Installation	85
3.3 Maintenance	86
<b>4.0 Validation</b>	<b>87</b>
4.1 Validation certificate	87
4.2 Tamper-evident sealing	89
<b>5.0 Meter reading</b>	<b>90</b>
<b>6.0 Workplace health and safety laws</b>	<b>90</b>
<b>7.0 Disclaimer</b>	<b>90</b>
<b>8.0 References and useful links</b>	<b>91</b>
<b>9.0 Further information</b>	<b>91</b>

## Appendices

<b>Appendix A – Glossary of terms</b>	<b>92</b>
<b>Appendix B – Maintenance record template (Module C)</b>	<b>93</b>
<b>Appendix C – Individual meters: Departmental requirements</b>	<b>94</b>

## Tables

<b>Table 1 - Existing meter</b>	<b>85</b>
<b>Table 2 - New meter – direct replacement</b>	<b>85</b>

## Figures

<b>Figure 1 - Validation</b>	<b>88</b>
------------------------------	-----------

# 1.0 Application

Module C (this module) of the standard applies to existing meters which continuously measure the depth of water over a small concrete rectangular weir measurement structure, calculates the flow of water that is passing the weir, and record the volume of water that has passed the weir.

The existing meters measures the extraction of surface water.

The following words have an important meaning in the standard:

**Must** Indicates that a statement is mandatory; Australian standards use 'shall' where a statement is mandatory. For this standard, 'must' is used instead of 'shall'.

**May** Indicates the existence of an option.

## 2.0 Output requirement

As a minimum, the meter must generate an electronic pulse output each time a set volume of water passes the weir. The output must allow the meter to interface with a transmission device and/or data logger.

The department will notify the relevant person where these devices (data logger and/or transmission device) must be attached to the meter.

## 3.0 Measurement assurance requirements

The meter must, at a minimum, comply with the requirements outlined below.

---

A. A meter specified in Section 3.1 must be used.

---

B. A small concrete rectangular weir measurement structure must have a test/calibration certificate demonstrating:

- i) After manufacture and prior to being placed into service, the errors of new pressure sensors or depth/height measurement devices, are within  $\pm 0.1\%$  of true value across the depth range of the sensor.
    - the sensor must be matched to the meter site. For example, for a meter site with a depth range of 3 meters, a sensor with a depth range of 5 meters would match the site. A sensor with a depth range of 30 meters would not match the meter site.
  - ii) The Certificate must show the serial number for the sensor.
- 

C. Installation of the meter must comply with the requirements specified in Section 3.2.

---

D. Periodic maintenance of the meter must comply with the requirements specified in Section 3.3, and the requirements below.

- i) A small concrete rectangular weir measurement structure must have periodic testing and/or calibration of individual sensors forming part of the system.
- 

E. Post-installation and before water is extracted through a new meter, the relevant person must engage an authorised meter validator to complete the actions in Section 4 and where the metering installation complies with the requirements of this standard, the authorised meter validator must provide a validation certificate to the relevant person.

---

F. On an ongoing basis, the relevant person must engage an authorised meter validator to complete the actions in Section 4 and where the metering installation complies with the requirements of this standard, the authorised meter validator must provide a validation certificate to the relevant person.

This process is called revalidation and must be completed within the 12-month period before, and by, the revalidation date published in Schedule 11 of the Water Regulation 2016 (Water Regulation).

---

G. Auditing may be undertaken by the department or its nominated representative. The details of auditing requirements are generally specified in departmental compliance monitoring plans, but the department may audit at any time and at any frequency deemed necessary.

## 3.1 Which meter can be used

At all times, the meter must have a clearly identifiable manufacturer’s serial number securely attached or imprinted on the controller.

The meter must use metric units e.g., kilolitres, megalitres.

### 3.1.1 Existing meters

The existing meter, shown in Table 1, can continue to be used subject to the other requirements of this module of the standard also being met.

The existing meter in Table 1, was confirmed to meet the specification under Measurement assurance Requirement B at the time these metering installations were installed and commissioned.

Table 1 - Existing meter

Meter type	Make	Model
Depth of water over a rectangular weir measurement structure	MACE	HydroMace + 3rd party pressure sensor

### 3.1.2 New meter – direct replacement

Where a new meter is required as a direct replacement for the existing meter, the meter shown in Table 2 can be used subject to the requirements of this module of the standard being met.

Table 2 - New meter – direct replacement

Meter type	Make	Model
Depth of water over a rectangular weir measurement structure	MACE	HydroMace, AgriFlo XCi or FloPro XCi + 3rd party pressure sensor

Where this direct replacement is not used, then a water meter conforming with the requirements of Module A – Water meters for surface and underground water of the standard must be used.

## 3.2 Installation

For the meter to comply it must meet all installation requirements of the department attached as Appendix C.

Extracted water must not bypass the metering installation.

### 3.2.1 Configuration

The meter must be configured to meet these general requirements:

- the internal data logger must be enabled
- logged data must not be lost, deleted, or reset during maintenance or validation
- measurement interval must be 5 minutes or less
- logging interval for measurements must be 60 minutes or less
- date and time must be set to Australian Eastern Standard Time by synchronising the device clock with an electronic device (e.g., computer, or mobile tablet device)
- where software/firmware enhancements occur, these must be upload to the device
- prior to update of software/firmware, the configuration setting, the logged data, and the device totals must be downloaded. Where this information is lost because of the update it must be uploaded to the device after the update is complete.



## 3.3 Maintenance

The meter must be maintained to meet department requirements.

Maintenance requirements for the meter are attached as Appendix C.

The authorised meter validator must prepare a maintenance report as per section 3.3.1.1.

The relevant person must keep a maintenance log as per section 3.3.1.2. This must be provided to the authorised meter validator during any process of revalidation or when the meter is faulty.

### 3.3.1 General requirements

#### 3.3.1.1 Maintenance – authorised meter validator

The following activities must be performed by an authorised meter validator during any process of revalidation (validation – ongoing) or when the meter is faulty. A maintenance report on these activities, confirming completion, must be provided to the relevant person with the validation certificate.

##### **Solar panel(s)**

- Check solar panel for build-up of material such as dust and bird droppings.
- Check solar panel has tri-spikes (or similar barrier mechanism) installed on the top of the solar panel to reduce the accumulation of bird dropping on the front face of the panel.
- Clean with a wet soft brush or cloth (do not use steel bristle brushes).
- Check solar panel is orientated to the North at the appropriate incline angle, and the panel must not be shaded by trees or structures.

##### **Metering equipment**

- Where visible and safe to do so, confirm electrical cables and connections are in good working order.
- Confirm register/display is clear and readable.
- Where it is safe to do so, confirm there are no leaks in the structure.
- The meter has an internal battery; inspect the 'replace battery by date' on the meter. Replace the battery, where required, and record on a tag attached to the meter or write inside a display housing door or lid, replace battery by dd/mm/yyyy. Use permanent ink or label with permanent ink.
- Complete other maintenance for the metering installation as required by the department – Appendix C.

#### 3.3.1.2 Maintenance – relevant person

The following maintenance activities must be performed by the relevant person annually, at a minimum. It is good practice to perform these maintenance activities on a more frequent basis. A maintenance log of these activities, confirming completion, is to be provided to the authorised meter validator during any process of revalidation (validation – ongoing) or when the meter is faulty. The maintenance log will assist the authorised meter validator in developing the required maintenance report. The maintenance log is a compilation of a series of maintenance records. A blank maintenance record is available in Appendix B.

##### **Emplacement / installation / site**

- Keep grass/vegetation around the site at a reasonable height.
- Clear away excess vegetation and debris.
- Confirm the site complies with Workplace Health and Safety requirements to ensure the safety of workers and visitors.
- Confirm the integrity of emplacement and fencing.
- Treat weed and vermin issues.

##### **Solar panels**

- The solar panel must be checked regularly for build-up of material such as dust and bird droppings.
- This activity must be undertaken as often as is necessary to keep the panel clean.
- Clean with a wet soft brush or cloth (do not use steel bristle brushes).

#### **Metering equipment**

- Where visible and safe to do so, confirm electrical cables and connections are in good working order.
- Confirm register/display is clear and readable.
- Confirm there are no leaks in exposed structure, and that extracted water is not bypassing the meter, where it is safe to do so.
- Confirm that you believe the meter is recording the volume of water extracted correctly.
- Confirm the meter and installation has mechanical tamper-evident seals, and that none of these seals are broken.

## 4.0 Validation

### 4.1 Validation certificate

Where the metering installation meets the requirements of this module of the standard, a validation certificate must be given to the relevant person within 20 business days of an inspection of the meter by an authorised meter validator.

The relevant person must give a copy of the validation certificate to the Department within 20 business days of receipt of the validation certificate.

Where the metering installation does not meet the requirements of this module of the standard, the authorised meter validator must provide the relevant person with a validation notice explaining why and any potential modifications that could allow the metering installation to become compliant. The relevant person or the authorised meter validator may provide a copy of this notice to the Department.

The Department validation form for this module is *W2F119C Module C - Water meter validation*.

Figure 1 describes the process and actions that must be completed by an authorised meter validator when undertaking a process of validation.

Figure 1 - Validation

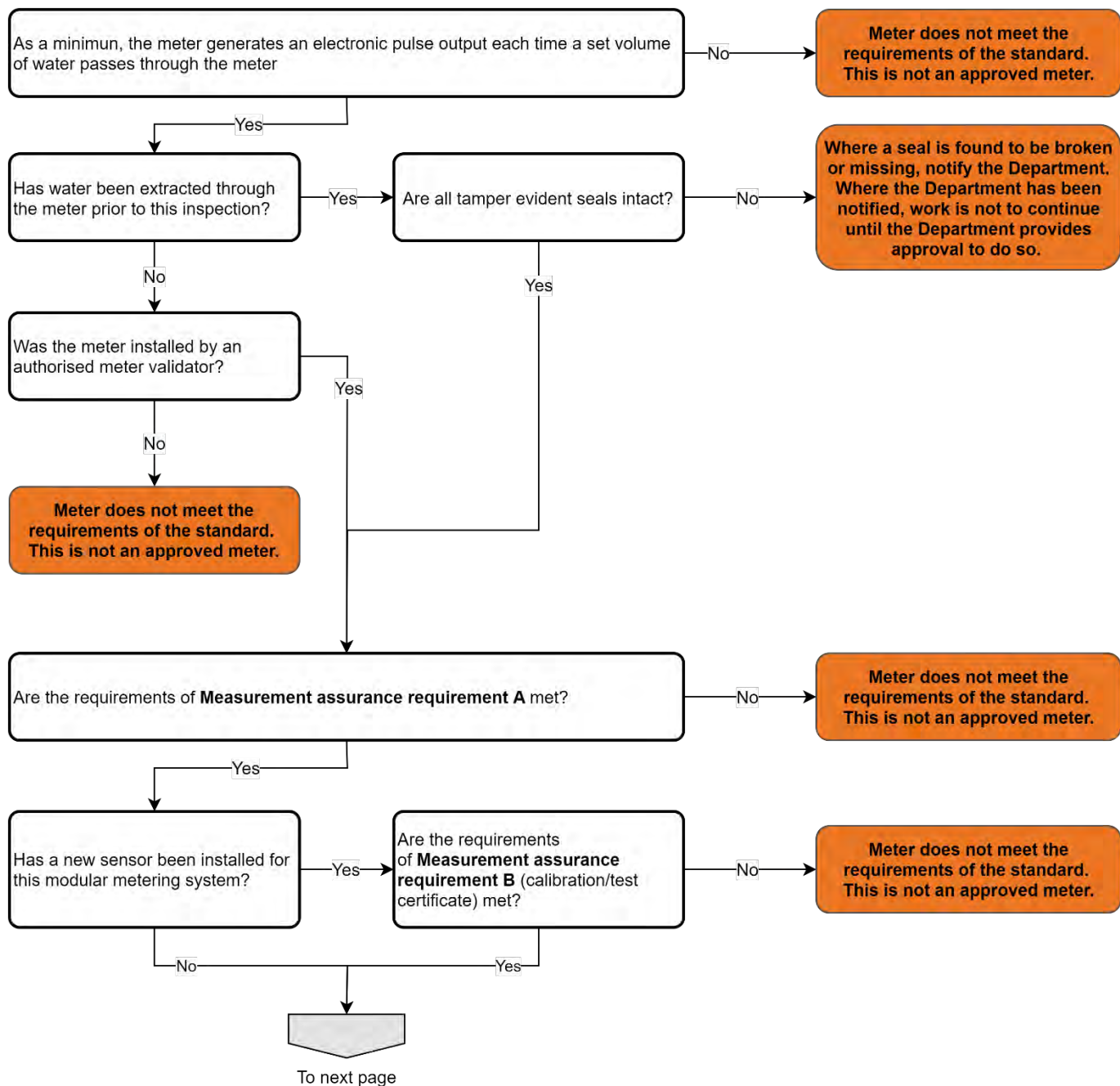

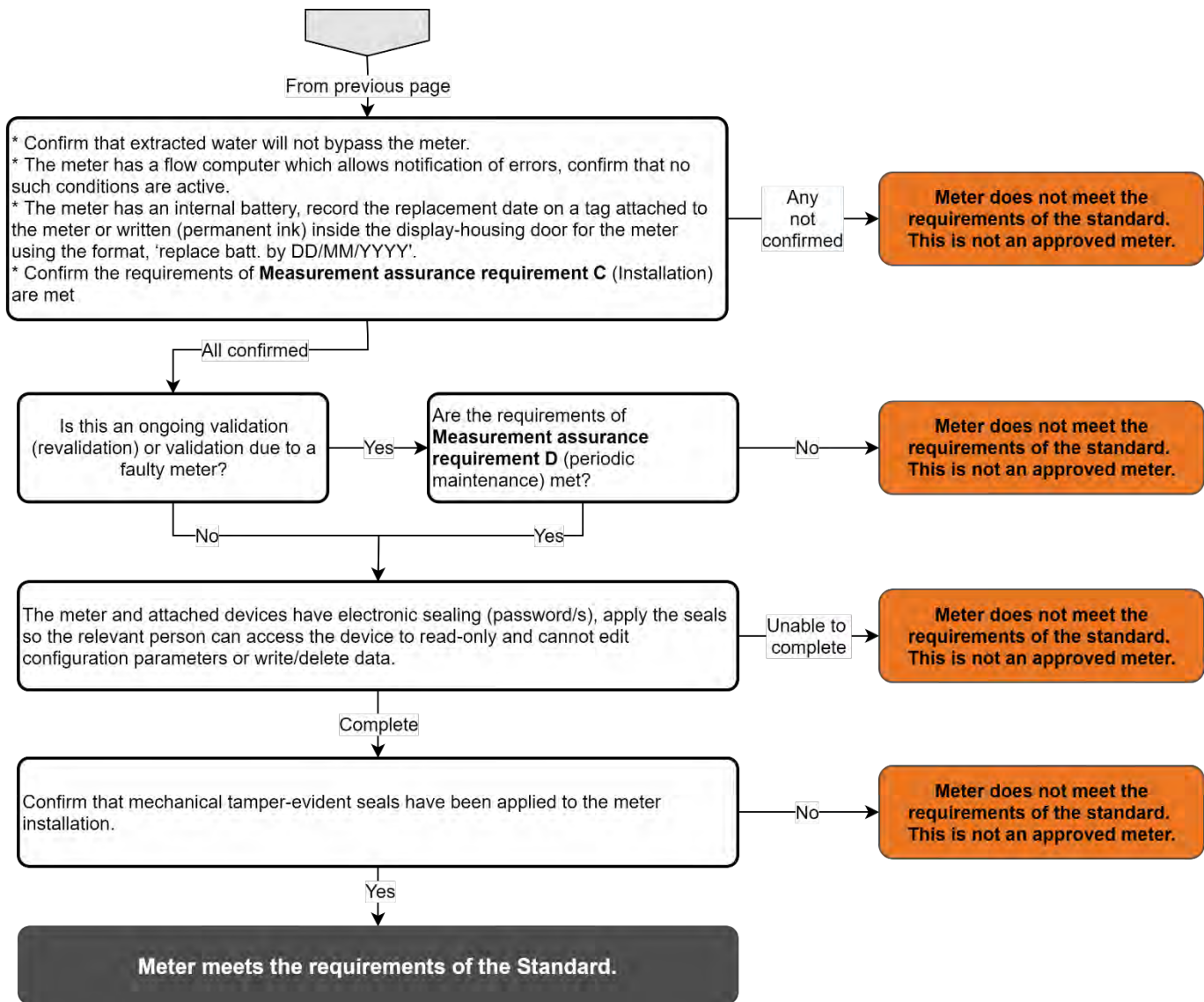

## 4.2 Tamper-evident sealing

Irrigation Australia Limited have published national guidelines on tamper-evident sealing of water meters for CMI's. The following requirements provide additional requirements under this module of the standard.

### 4.2.1 Mechanical seals

The sensors must have mechanical tamper evident seal(s) applied so that they cannot be removed or disconnected, without breaking the seal(s)

The logger must have mechanical tamper evident seal(s) applied so that it cannot be moved, opened, or the sensors cannot be disconnected, without breaking the seal(s).

Where the meter has an external power supply, this connection/s must have mechanical tamper evident seals so that the device cannot be disconnected from the power supply.

### 4.2.2 Electronic sealing

Where the meter has a default password from the factory, the authorised meter validator must change the password.

Where the authorised meter validator is uncertain if the relevant person knows the password, they must change the password. The relevant person must not be able to edit, delete or upload, logged data, including configuration settings.

## 5.0 Meter reading

As detailed in Section 2.0 Output Requirement, as a minimum, the meter must generate an electronic pulse output each time a set volume of water passes through the meter. The output must allow the meter to interface with a transmission device and/or data logger.

The department can require data loggers to be fitted to any meter to facilitate more efficient meter reads.

A data logger is a low power device designed to collect and temporarily store readings from a variety of outputs in remote or unattended locations. A logger has an inbuilt clock that timestamps the data entry to allow for data review later.

Installing data loggers on meters allow for the retrieval of more comprehensive water extraction information. Loggers are installed to:

- minimise the time spent on meter reading
- minimize the cost of meter reading
- capture time and event data
- monitor for water extraction compliance.

Information on data logger requirements can be found in the Guideline – Data logger specifications for water meters. A link to this document can be found in section 5.

Metered entitlement holders are required to provide a meter reading to the Department in accordance with a meter reading notice given under the Water Regulation 2016 and in accordance with the *Queensland Non-urban Water Metering Policy for Unsupplemented Water Extraction 2019*. It is likely that data loggers will be required where:

- water extractions are subject to time and/or passing flow and/or rate of take conditions
- it would support more effective and efficient meter reads.

## 6.0 Workplace health and safety laws

The *Work Health and Safety Act 2011* (WHS Act) provides a framework to protect the health, safety and welfare of all workers at work. It also protects the health and safety of all other people who might be affected at work.

The WHS Act places the primary health and safety duty on a person conducting a business or undertaking (PCBU). The PCBU must ensure, so far as reasonably practicable, the health and safety of workers at the workplace. Duties are also placed on officers of a PCBU, workers and other persons at a workplace.

With the above requirements in mind, note that a metering installation can be visited by a range of people throughout its service-life. These could include:

- the PCBU
- workers (including an authorised meter validator, fabricators and fitters, mechanics, electricians)
- authorised officers of the department.

## 7.0 Disclaimer

Nothing in the standard is intended to contradict the manufacturer's operating and installation directions that would void manufacturer's warranty or that would indirectly or directly result in loss or liability for which the Department expressly disclaims responsibility.

Any contradiction between the standard and the *Water Act 2000* or Water Regulation 2016 will be managed by the following hierarchy, in order: (i) the *Water Act 2000*, (ii) the Water Regulation 2016, and (iii) the standard.

## 8.0 References and useful links

Department Regional Development, Manufacturing and Water, 2019, *Queensland Non-urban Water Metering Policy for Unsupplemented Water Extractions 2019*, Queensland Government, Brisbane, 7 June 2021, <[https://www.dnrme.qld.gov.au/?a=109113:policy\\_registry/water-meter-non-urban-unsupp.pdf](https://www.dnrme.qld.gov.au/?a=109113:policy_registry/water-meter-non-urban-unsupp.pdf)>.

Irrigation Australia, 2021, 'Certified Meter Installer & Validator', Brisbane, viewed 7 June 2021, <<https://www.irrigationaustralia.com.au>>.

Murray-Darling Basin Authority, 2021, 'Compliance and enforcement documents', viewed 7 June 2021, <<https://www.mdba.gov.au>>.

### Legislation

*Water Act 2000* (Qld). Retrieved from <<https://www.legislation.qld.gov.au/view/pdf/inforce/current/act-2000-034>>.

Queensland Water Regulation 2016 (Qld) Retrieved from <<https://www.legislation.qld.gov.au/view/pdf/inforce/current/sl-2016-0216>>.

## 9.0 Further information

Further information on water metering is available on the Queensland Government website at <<http://www.business.qld.gov.au>> or call 13 QGOV (13 74 68).

# Appendix A – Glossary of terms

Term	Definition
<b>Authorised meter validator</b>	A person who is accredited by Irrigation Australia Limited as a 'certified meter installer and validator'. A list of people with this accreditation can be found by clicking the 'certified meter installer and validator' tab at, < <a href="https://www.irrigationaustralia.com.au/">https://www.irrigationaustralia.com.au/</a> > Alternatively, this person can be appointed by the department, where they have the necessary expertise or experience to perform this function
<b>CMI</b>	An authorised meter validator who is accredited by Irrigation Australia Limited as a 'certified meter installer and validator'. A list of people with this accreditation can be found by clicking the 'certified meter installer and validator' tab at, < <a href="https://www.irrigationaustralia.com.au/">https://www.irrigationaustralia.com.au/</a> >
<b>Data logger</b>	A low power device attached to the meter which is designed to collect and store readings (in this instance a pulse or group of pulses from the meter). The device has an inbuilt clock that timestamps each reading, allowing the data to be downloaded and reviewed later. Some meters have this functionality built into the meter.
<b>Existing meter</b>	A metering installation which was installed and commissioned prior to the commencement of this module of the standard
<b>New meter – direct replacement</b>	A meter which was installed and commissioned after the commencement of this module of the standard
<b>Relevant person</b>	Can be a water authorisation holder, or the owner of works used for taking or interfering with water, or the person nominated to represent them in departmental systems
<b>Small concrete rectangular weir</b>	A concrete measurement structure with a crest less than 2 meters in width, which changes the water flow characteristics and is used to measure the volumetric rate of water flow.
<b>Surface water</b>	<ul style="list-style-type: none"> <li>a. water in a watercourse or lake, or</li> <li>b. water in a spring not connected to water to which the Water Plan (Great Artesian Basin and Other Regional Aquifers) 2017 applies, or</li> <li>c. overland flow water, other than water in a spring connected to water to which the Water Plan (Great Artesian Basin and Other Regional Aquifers) 2017 applies</li> </ul>
<b>Transmission device</b>	A device that transmits readings (in this instance a pulse or a group of pulses from the meter) to a central data store where it can be reviewed in near-real time. The device has an inbuilt clock that timestamps each transmission. This process is sometimes referred to as telemetry.
<b>Validation</b>	A set of activities performed by an authorised meter validator, that includes: inspecting the meter to confirm it complies with this module of the standard confirming the meter is installed in compliance with this module of the standard and is maintained to an acceptable state of repair. Providing confidence that the meter will operate within an acceptable range of error under normal operating conditions.

## Appendix B – Maintenance record template (Module C)

Maintenance Record – Meter Serial No:		Date of maintenance:
Emplacement / Installation / site	Keep grass/vegetation around the site at a reasonable height	<input type="checkbox"/> Completed <input type="checkbox"/> Not required at this inspection
	Clear away excess vegetation and debris	<input type="checkbox"/> Completed <input type="checkbox"/> Not required at this inspection
	Confirm the site is WHS compliant – safe for workers and visitors	<input type="checkbox"/> Completed
	Confirm integrity of emplacement and fencing	<input type="checkbox"/> Completed
	Treat weed and vermin issues	<input type="checkbox"/> Completed <input type="checkbox"/> Not required at this inspection
Solar panel/s	The solar panel must be checked regularly for build-up of solids such as dust and bird droppings - this activity must be undertaken as often as is necessary to keep the panel clean. Clean with a wet brush or rag (do not use steel bristle brushes)	<input type="checkbox"/> Completed <input type="checkbox"/> Not applicable
Metering equipment	Where visible and safe to do so, confirm electrical cables and connections are in good working order	<input type="checkbox"/> Completed <input type="checkbox"/> Not safe to do so <input type="checkbox"/> Not applicable
	Confirm register/display is clear and readable	<input type="checkbox"/> Completed
	Confirm there are no leaks in structure and that extracted water is not bypassing the meter, where it is safe to do so	<input type="checkbox"/> Completed <input type="checkbox"/> Not safe to do so <input type="checkbox"/> Not possible
	You believe the meter is correctly recording the volume of water extracted	<input type="checkbox"/> Confirmed <input type="checkbox"/> Notified department – faulty meter
	The meter installation has mechanical tamper-evident seals, and none of these seals are broken	<input type="checkbox"/> Confirmed <input type="checkbox"/> Notified department – faulty meter
Name of person who completed this maintenance:		Signature:
Tick one: <input type="checkbox"/> Water authorisation holder <input type="checkbox"/> Employee <input type="checkbox"/> Contractor		Date:



# Appendix C – Individual meters: Departmental requirements

## Appendices

MACE – XCi & HydroMace

95

# MACE – XCi & HydroMace

The following requirements do not replace the XCi Product Manual or the HydroMace Product Manual. The manual is essential for the successful installation, commissioning, operation, and maintenance of this device, and must always be used.

However, for use of this meter under this module of the standard the following requirements must be met, as a minimum, and have been formulated from recommendations/advice in the manual and where required with input from the manufacturer.

Requirements to be confirmed by validation type	
<b>Existing meter installation – new logger and or new sensor/s installed as direct replacement</b>	Section 2.0, Section 3.0, Section 4.0, Section 5.0, Section 7.0, and Section 9.0
<b>Ongoing (revalidation) or Faulty meter (maintenance) – existing meter installation - new or replacement sensors only and no new logger</b>	Section 2.0, Section 3.0, Section 4.0, Section 5.0, Section 7.0, Section 8.0, and Section 9.0
<b>Ongoing (revalidation) or Faulty meter (maintenance) – existing meter installation - new logger only and no new or replacement sensors</b>	Section 4.0, Section 5.0, Section 6.0, Section 7.0, Section 8.0, and Section 9.0
<b>Ongoing (revalidation) or Faulty meter (maintenance) – existing meter installation - no new or replacement logger and no new or replacement sensors</b>	

Note: The requirements only reference the XCi but these requirements must also be met with the HydroMace. Where the requirements cannot be met with a HydroMace, this has been noted.

## 1.0 Key terms

Term	Definition
<b>pressure sensor</b>	A stand-alone third-party sensor/s
<b>XCi</b>	The MACE AgriFlo XCi or FloPro XCi including connected sensors.
<b>Logger</b>	The controller/logger component of the XCi

## 2.0 Authorised Meter Validator

From 1 December 2022, a CMI must have completed training by MACE for the XCi within the previous 2 years to perform the activities in the following table. The training record/certificate must be provided with the validation certificate where a new sensor is installed.

Activity	CMI	Training by MACE
<b>Installation of new sensors</b>	✓	✓

## 3.0 Measurement assurance requirement B

New pressure sensors must be calibrated after manufacture and prior to installation, and the manufacturer must certify that the sensor will measure depth within  $\pm 0.1\%$  of true value across the depth range.

The new sensor must be provided with a calibration certificate showing:

- date of the calibration test
- the serial number of the reference device
- the sensor type, manufacturer part number, and the serial number for the sensor
- the depth range over which the sensor was tested
- the calibration results confirming  $\pm 0.1\%$ , or, that the sensor has 'passed' the test.

The new sensor must withstand temperatures from  $-50^{\circ}\text{C}$  to  $+50^{\circ}\text{C}$  and relative humidity's of 100% (without condensation) in a non-operating condition.

## 4.0 Installation

### 4.1 General

The logger must:

- Water damage – be mounted above known flood peak levels. The logger must NOT be submerged.
- Sunlight - be mounted so that the LCD faces in a direction away from direct sunlight (i.e., LCD must face South).
- Cable damage – have all cables appropriately routed through electrical conduit when not enclosed in any mounting pole.
- Insects and moisture – have a non-curing sealing compound (e.g., duct-seal-putty) installed down the first 5 to 10 cm of electrical conduit or the mounting pole where cables are enclosed, to prevent insect/moisture ingress.
- Power – have an alternate DC source of 16-30V DV connected to the logger power regulator to charge the internal battery (i.e., a mains powered trickle charger or a solar panel, where mains power is not available). The cables from the solar panel/charger to the logger must be enclosed in electrical conduit when not enclosed in any mounting pole (also see Insect and moisture requirement above).
- Solar panel - have tri-spikes installed on the top of the solar panel to reduce the accumulation of bird droppings on the front face of the panel; and the solar panel orientated to the North at the appropriate incline angle, and the panel must not be shaded by trees or structures.

### 4.2 Pressure sensor

The sensor cable must not:

- have any connections between the sensor and the logger (so the sensor cannot be disconnected inadvertently or to facilitate fraud).

The sensor must:

- be installed in a stilling well/pipe.
- connect to the logger, where measurements must be logged
- obtain power from the logger.

## 5.0 Configuration

### 5.1 Site ID

Must be the logger serial number.

When a validation certificate is issued for the XCi, it must link:

- the logger serial number (Site ID), to the
- water resource extraction authorisation number(s), to the
- works number(s) for extraction occurring against an authorisation, to the
- latitude and longitude for the meter location
- the serial number(s) for the sensor(s) connected to the logger.

Where the controller card is replaced, the serial number for the new card must be linked to the metering installation with a validation certificate. The new serial number must be permanently recorded inside the logger using a label or tag.

### 5.2 The XCi channels

The XCi uses channels to enable various measurements to be made and other parameters to be calculated. There are three types of channels:

- Connected sensor channels – these channels output the measured value based on the signal received from physically connected sensors wired to the logger.
- Calculated channels – these channels use the measured values (connected sensor channels) and apply an algorithm(s) to output calculated values.
- System channels – these channels use system values direct from the logger.

#### 5.2.1 XCi – Metering – small concrete rectangular weir measurement structure

CONFIGURATION 3: Measurement of depth of flow over a concrete rectangular weir, with flowrate calculated using a depth to volume algorithm for the weir.

- A pressure sensor signal is converted to a depth output by the logger using a 'depth channel'.
- The depth output is then used to calculate flowrate via a 'flowrate channel' by using a pre-configured algorithm for the structure.

For these existing weirs treat them as a suppressed rectangular weir  $\rightarrow Q = 1.84 * L * h^{1.5}$ , where:

Q = discharge (kL/second); L = weir width (m); and h1 is the upstream height measured by the pressure sensor (m).

Following are minimum requirements for 'Channels' to be configured and confirmed for the metering installation.

Channels	Channel type	Configuration 3
<b>Depth</b>	Connected sensor	✓
<b>Flowrate (using weir)</b>	Calculated	✓
<b>Total flow</b>	Calculated	✓ The 'non-resettable' check box must be ticked.## The 'total positive flow' check box must be ticked.

Channels	Channel type	Configuration 3
<b>Net flow total</b>	Calculated	✓ The 'non-resettable' check box must be ticked.## The 'all values' check box must be ticked.
<b>Device battery voltage#</b>	System	✓
<b>Device external voltage#</b>	System	✓

# Essential meter health elements, i) the logger internal battery and alternate DC power source voltage, making it easier to identify if the meter is/when the meter became faulty.

## Essential tamper-evident/prevention elements, i) stopping unauthorised persons from resetting the XCi totals; either inadvertently or to facilitate fraud.

## 6.0 Pressure sensor check

The sensor 'offset' must be confirmed and checked. The offset is the level that the sensor is positioned relative to the crest of the concrete rectangular weir.

Where the water level is over the sensor, the reading must also be confirmed against another measurement device. For example, a tape or ruler.

Where the water level is not over the sensor, the sensor must be confirmed to be reading correctly against another measurement device. For example, submerging the sensor and confirming the level matches that of a tape or ruler.

Where the sensor fails the check, a new sensor must be installed.

A report on this activity, confirming completion, is to be provided to the relevant person with the validation certificate.

## 7.0 Output

Where the department requires meter health as an output from the meter:

The logger must have a FloSI card installed. To have a validation certificate issued, where an XCi:

- is installed after this document came into effect - it must have a card installed as part of validation post-installation
- was installed prior to the effect of this document - it must have a FloSI card installed as part of the next process of validation for the XCi.

The FloSI Card provides output from the XCi for interface with third party transmission devices.

A WebComm card may be used where the department confirms this is possible. This card provides cellular output from the XCi to the Department's nominated data platform.

Where the department requires pulse output only:

The logger must have a Pulse I/O card installed. To have a validation certificate issued, where an XCi:

- is installed after this document came into effect - it must have a Pulse I/O card installed as part of the process of validation, post-installation
- was installed prior to the effect of this document - it must have a Pulse I/O card installed as part of the next process of validation for the XCi.

The Pulse I/O card provides output from the XCi for interface with third party transmission devices.

## 8.0 Maintenance

### 8.1 Battery replacement

The XCi internal battery must be replaced every 5 years, as a minimum, regardless of perceived battery status.

The logger control panel battery must be replaced when the internal battery is replaced, regardless of perceived battery status.

### 8.2 Pressure sensor

The pressure sensor must be checked (6.0 Pressure Sensor Check).

Where the sensor fails, a new sensor must be installed.

Department of Regional Development,  
Manufacturing and Water  
GPO Box 2771, Brisbane, Queensland 4001  
13 QGOV (13 74 68)  
[info@rdmw.qld.gov.au](mailto:info@rdmw.qld.gov.au)  
[rdmw.qld.gov.au](http://rdmw.qld.gov.au)



**Queensland**  
Government