

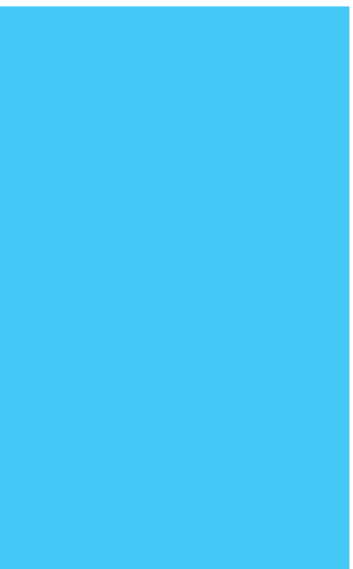

Nursery Industry Water Management Best Practice Guidelines

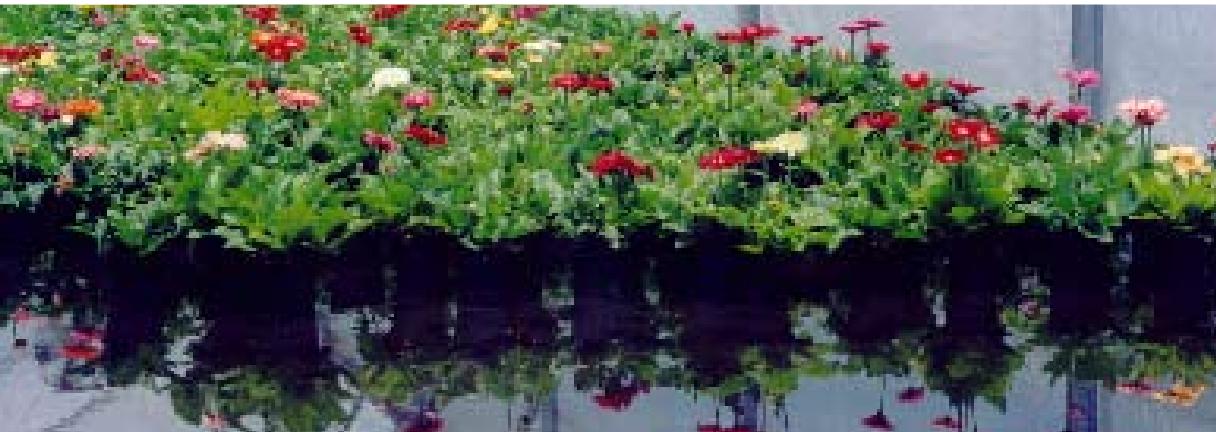



Nursery Industry Water Management Best Practice Guidelines





FOREWORD

The Nursery and Garden Industry is committed to supporting healthy, thriving and viable businesses by investing industry levy funds into research, tools and other activities which promote best practice and improve profitability.

The viability of the nursery and garden industry is dependant on the availability of water for use in the production and care of plants and the *Nursery Industry Water Management Best Practice Guidelines* were developed in 1997 to promote best practice water management in production nurseries.

With the current water shortages and changing water policy it is more important than ever before for our industry to achieve reductions in water use and demonstrate a commitment to responsible water management. Best practice plays an important role in achieving these outcomes and in response a review of the guidelines was undertaken to ensure that they include the most up to date practices and effectively address the needs of the current situation.

The 2010 updated guidelines include:

- a new Chapter that details irrigation management tools
- updated references from Levy Funded Research and Development Projects
- additional information on irrigation systems, irrigation system design and planning
- additional information on water testing and monitoring water quality

Your business will benefit from the practical application of these guidelines with outcomes such as improved plant quality, increased uniformity, reduced water requirements, and associated cost savings.

In addition the practices outlined in this document demonstrates the commitment of the nursery and garden industry to sustainable water use and provide opportunities for your business to demonstrate its on-going role in responsible water management.

Bryan Hillier
President, Nursery & Garden Industry Australia



ACKNOWLEDGMENTS

This publication is the result of an initiative of the National Technical Committee responsible for nursery industry research and development. In particular, a special thanks is extended to the past chairperson of this Committee, Jolyon Burnett. The 2010 revision has been overseen by the National NIASA Advisory Committee (NNAC), Chaired by Gary Eyles. The coordinator also wishes to thank the many staff from departments of agriculture, primary industries, water, and the environment who have contributed to the development of this publication. A special thanks to industry members who took the time to review the draft guidelines.

Nursery Industry Water Management
Best Practice Guidelines

Update 2005

Edda Keskula, Nursery & Garden Industry, South Australia
John McDonald, Nursery & Garden Industry, Queensland

Update 2010

Michael Danelon, Nursery & Garden Industry, New South Wales and Australian Capital Territory
Anthony Kachenko, Nursery & Garden Industry Australia
John McDonald, Nursery & Garden Industry, Queensland
Chris Rolfe, NSW Agriculture (retired)
Bill Yiasoumi, NSW Industry & Investment

Original contributors

David Beardsell, Agriculture Victoria – Chapter 2
Keith Bodman, Queensland Department of Primary Industries – Chapter 5
Geoff Cresswell, ex-NSW Agriculture – Chapter 4
Martin Mebalds, Agriculture Victoria – Chapter 2
David Nicholas, DebCo Pty Ltd, Victoria – Chapter 4
Chris Rolfe, NSW Agriculture (retired) – Chapter 1 and input into the 2010 revision
Bill Yiasoumi, NSW Industry & Investment – Chapter 3 and input into the 2010 revision

Senior editor (2005): Ian Atkinson, Nursery & Garden Industry Australia
Word editor (2005): Anne Currey, Carmichael Currey
Senior editor (2010): Anthony Kachenko, Nursery & Garden Industry Australia

ISBN 0 646 31160 3

© 2010, Nursery & Garden Industry Australia
PO Box 907
Epping NSW 1710
Phone: 02 9876 5200 Fax: 02 9876 6360
E-mail: info@ngia.com.au

First printed 1997, reprinted with minor corrections 1999 and updated in 2005 and 2010

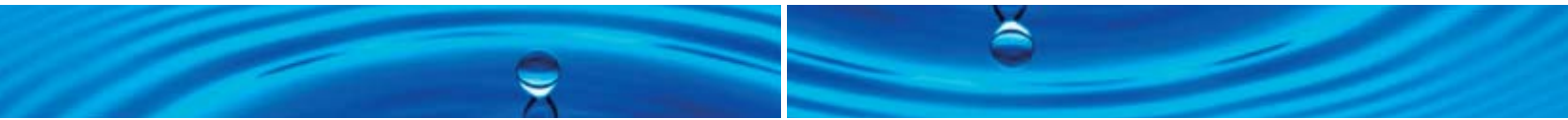

CONTENTS

FOREWORD i

ACKNOWLEDGEMENTS ii

INTRODUCTION v

CHAPTER 1
Efficient water use to minimise the business’ demand on the water resource 1

CHAPTER 2
Irrigation management tools to ensure more productive and efficient use of water 24

CHAPTER 3
Increased re-use of nursery waste water to reduce business demand on the water resource 37

CHAPTER 4
Effective management of sediment and litter and drainage 50

CHAPTER 5
Maximising the retention of nutrients to improve the efficiency of production and maintain water quality 67

CHAPTER 6
Environmentally responsible use of plant protection products in quality plant production 75

APPENDICES

APPENDIX 1
Calculating Coefficient of Uniformity, Mean Application Rate and Scheduling Coefficient 84

APPENDIX 2
Input data for Nursery Production Economic Model 87

APPENDIX 3
Considerations when developing a drainage, sediment and litter control plan 89

APPENDIX 4
Pour-through technique 92



INTRODUCTION

Over the last 20 years the Australian nursery and garden industry, in partnership with Horticultural Australia Limited, has invested in research to deliver practical outcomes in the areas of improved irrigation practices, more efficient water use, water recycling and disinfestation technology, as well as funding training and extension to deliver this information to industry.

This publication aims to incorporate all the available information into a set of Best Practice Guidelines. It is intended as a practical guide for both nursery operators and the relevant authorities to use to achieve outcomes that are economically and environmentally sustainable. This guide looks at the six goals for achieving sustainable water use:

1. Efficient water use to minimise the business' demand on the water resource.
2. Irrigation management tools to ensure more productive and efficient use of water.
3. Increased reuse of waste water to minimise the demand of the business on the water resource.
4. Effective management of sediment and litter.
5. Maximising the retention of nutrients to improve efficiency of production and maintain water quality.
6. Environmentally responsible use of plant protection products to produce quality products.

This publication is a guide only and is not intended as a 'do-it-yourself' implementation manual. It should be used in conjunction with the detailed references that are listed in each chapter and with the advice of suitable experts from both government and private enterprise. The State/Territory Nursery & Garden Industry Association and local government offices will be able to assist in identifying these people and in accessing the most up to date information and research.

These best practice guidelines also form the basis for the Water Chapter that is included in the Nursery Industry Accreditation Scheme, Australia (NIASA) Manual and can be used as a reference for achieving the requirements of this section.

In combination with continuing research and the implementation of the industry's National Water Policy these guidelines demonstrate the commitment of the nursery and garden industry to responsible water use and to achieving on-going improvements in water management within industry businesses.

Dr Anthony Kachenko
National Environmental & Technical Policy Manager
Nursery & Garden Industry Australia
October 2010



1 EFFICIENT WATER USE TO MINIMISE THE BUSINESS' DEMAND ON THE WATER RESOURCE

Growing a healthy plant to market specification requires the right amount of water and nutrients as well as a suitable growing environment. Plants growing under optimum conditions of light, temperature, nutrition and water will reach marketable size as quickly as possible. If conditions are below optimum, plant growth will be slower, plants may need more nutrients and water, and turnover will be slower.

Ineffective irrigation is the one operation that most often accounts for poor product quality and quality variations in plants produced in the nursery. Under or over watering and uneven water application can lead to under, over or uneven nutrient uptake, which affects quality and consistency of production.

Applying water evenly, to replace only the losses from the containers with a small leaching fraction, will result in substantial savings in water consumption, less contaminated waste water and more even and efficient fertiliser uptake. At the same time a better quality plant can be grown while enhancing the clean, green image that the industry is keen to present. The effort required is not as involved as you may think and can be achieved using a little bit of common sense under the guidance of this document.

The irrigation system you select will depend a great deal on the range of plants you intend to produce, the flexibility you wish to build into your operation, the quality of the water, and how much of it there is available and when it is available. An efficient system that applies water evenly and can be easily controlled to meet the variations of plant water requirements will provide a surprisingly attractive cost/benefit ratio.

This first section of this chapter will examine each type of irrigation system, set out the best management practice and provide some of the management considerations that will help you select the best, most efficient system for your business.

Once you have selected the types of irrigation systems that suit your operation, you then need to give thought to the irrigation design so that it not only applies water efficiently but also fits into the constraints of your business. To this end, the second section of this chapter will provide some aspects of the design that you as an owner/manager will need to consider before talking to an irrigation designer.

IRRIGATION SYSTEMS

There are two major methods of applying water that nursery operators can use in their nurseries, each with several available systems. They are:

1. Top watering

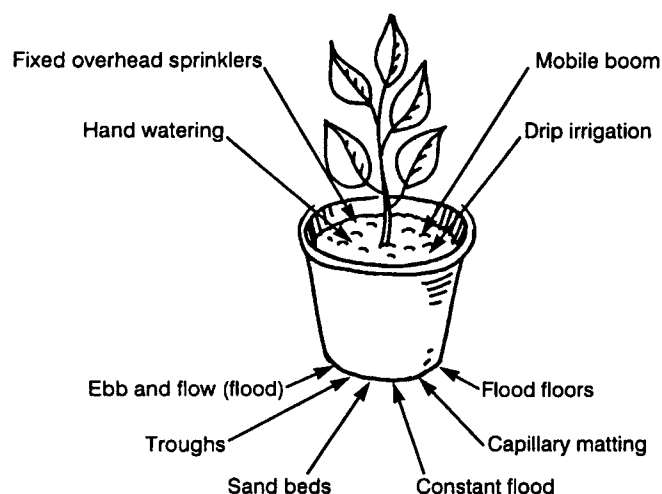

2. Bottom watering

Nursery operators may find that a mixed selection of these systems best suits their operation and plant/container range.

TOP WATERING

Fixed overhead sprinkler systems

Fixed overhead sprinkler systems comprise sprinklers set up on a grid pattern. These sprinklers can be either upright or upside down on rigid piping, at a spacing and operating pressure to provide an acceptable pattern to achieve a Coefficient of Uniformity of at least 85 %.

Spacings and discharge rates should be selected to ensure the mean application rate is less than the absorption rate of the potting media (normally less than 20 mm/hour).

Most irrigation systems are run for sufficient time to apply enough water to the driest containers. These are usually found around the edges of blocks. With uneven watering this practice leads to excessive water use and fertiliser leaching. To reduce this practice the Scheduling Coefficient should be less than 1.5.

System standard

Coefficient of Uniformity (Cu) > 85 %
Mean Application Rate (MAR) < 20 mm/hour
Scheduling Coefficient (Sc) < 1.5

To calculate whether your system meets the standard, refer to Appendix 1 in this publication. To determine how to calculate these measurements for your existing system you should attend a Waterwork workshop run by your State/Territory Nursery & Garden Industry Association.

FEATURES

The important features of fixed overhead sprinkler systems are as follows:

- relatively cheap to install
- low labour input
- keep foliage clean
- can be used to cool plants and maintain humidity.

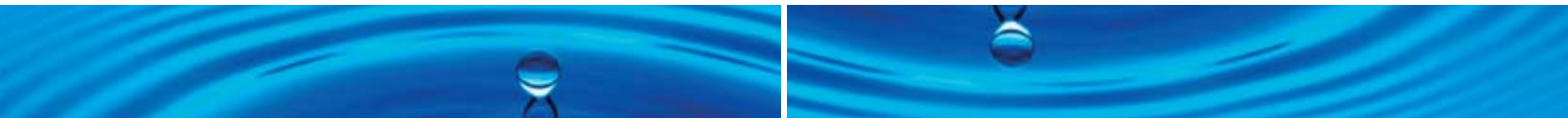

Mobile boom sprinklers

Flexibility and even water application is the secret of a well-designed overhead mobile boom system. A mobile boom system consists of one or more pipes fitted with nozzles that apply water as the system moves over the plants. It may be suspended from an overhead rail system or from a trailer that moves down the aisle. Water is supplied by a hose and the boom is powered by electrically driven cables or batteries.

These systems operate at a pressure to give the best breakup of the jet stream and droplet size (about 200 kPa). The spacing of the sprays should produce a Cu close to 100 %. With a selection of spray nozzles and speeds these systems can water a wide range of plants.

The boom should be wide enough to cover the container area and produce a Sc close to 1.0.

The spray jet size and diameter of coverage can be selected so that the MAR is closely matched to the absorption rate of the growing media. Control devices should be installed to make the boom capable of various speeds, thus giving the system the ability to meet the full range of applications required by the product being irrigated. Most booms apply water at rates of 1–3 mm/hour.

These light applications are ideal for small containers like plugs or seedling trays where good water and fertiliser control is vital for efficient production. By using multiple nozzles these systems can be used for not only irrigation but also applying liquid fertilisers and fungicides by selecting the nozzle that provides the prescribed application rate and droplet size.

If operated outdoors, care should be given to wind protection as the small droplets produced by these systems are very susceptible to wind drift, destroying their high uniformity of coverage.

A range of nozzles is available and these broadly fall into three categories hollow cone, solid cone and fan nozzles.

Hollow cone nozzles are most commonly used for spraying insecticides and fungicides. The pattern is produced by the swirling action of the spray liquid within the nozzle. Droplets leave the nozzle with high energy which results in a further breakdown of droplet size. The higher the pressure the smaller the droplet size.

Solid cone nozzles are used for spraying insecticides and fungicides at higher volume. The solid cone pattern is usually produced by a 'disc-core' combination. The disc is simply a plate with a circular orifice available in different sizes. The core, which is fitted behind the disc, produces a swirling action and spray pattern similar to a hollow cone nozzle. The core, which also has a hole in the centre, produces a stream that fills in the centre of the hollow cone spray pattern resulting in a solid cone of spray with variable droplet sizing.

Fan nozzles commonly come in three types; even flat nozzles, tapered fan nozzles and low pressure fan nozzles.

Even flat nozzles distribute water evenly across the nozzle swath and are used where a uniform spray application is required across the full width of the band. Different nozzle height settings will provide different band widths. For information use the manufacturer's recommendations.

Tapered fan nozzles produce a tapered distribution across the nozzle swath and are commonly used in spraying flat surfaces such as germination trays. The nozzles are aligned so that the fans are offset by 12° to 15° to avoid the spray patterns interfering with each other. Normally the spray overlaps about 30 % on each side with the combined output of adjacent nozzles giving the required application uniformly across the boom. Height adjustments for tapered nozzles should be made according to manufacturer's recommendations.

FEATURES

The important features of a mobile boom system are as follows:

- Even watering
Coefficient of Uniformity of nearly 100 %
- Scheduling Coefficient of almost 1
- Consistent application rate allows accurate watering and fertigation
- Light applications suitable for seedlings and bedding plants
- Nozzle range provides control of mist and irrigation during germination until plugs fill their cells
- Booms use 40 % less water than handwatering
- Booms use 25 % less water than upright sprinklers
- Less labour is needed as water is applied automatically
- Better water control can provide accurate plant water requirements.

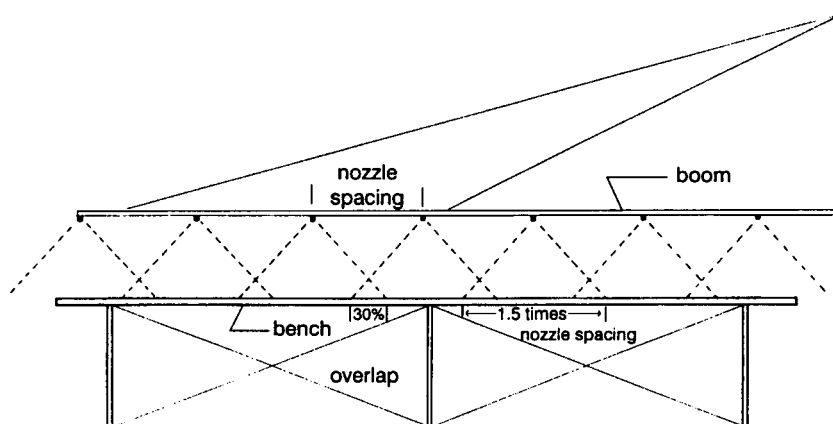

Fig. 1 – Mobile boom irrigation provides even, light (e.g. 5 mm/hr) applications of water which are ideal for plugs and flats

The effect of different plant heights on application rates and uniformity can be minimised by double coverage. This can be achieved most easily by halving the nozzle spacing or by doubling the boom height above the plant canopy. Alternatively, nozzles with a fan angle of 110° can be fitted at the normal spacing of 500 mm and used at a boom height of 500 mm.

In relation to pressure, the following general statements can be made:

- Droplet size decreases as pressure increases (for any particular nozzle).
- Droplet size increases as the orifice size increases (for any given pressure).
- Droplet size decreases with the increase in fan angle (for a given nozzle size and pressure).
- Fan angle increases with pressure.

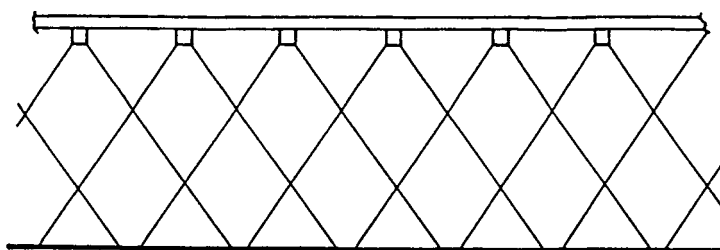

Fig. 2 – Double coverage spray pattern to minimise the effects of plant canopy height variation

Low pressure fan nozzles are designed to produce conventional spray patterns, flow rates and spray angles at pressures as low as 70 kPa. Droplets are larger, resulting in reduced drift and low pressure. Their larger orifices will increase the life of each tip and reduce blocking problems.

Some systems are available with more than one boom. These can be fitted with nozzles with different application rates for misting, feeding or pest control.

Choose the nozzle discharge rate and wetted area of the sprays so that the instantaneous application rate does not exceed 12 mm/hour.

System selection

Before launching into this type of irrigation system, you should discuss your requirements carefully with the boom manufacturer and supplier so that a system can be installed to meet these requirements.

Nursery windbreaks to protect overhead Irrigation systems

Windbreaks are not only required for container plants in the open but for the sprinklers that provide them with water. Wind over 8 km/hour will badly distort most sprinkler and spray patterns and destroy good irrigation uniformities. Windbreaks must therefore be designed to protect not only the sprinklers but the trajectory of the jet stream.

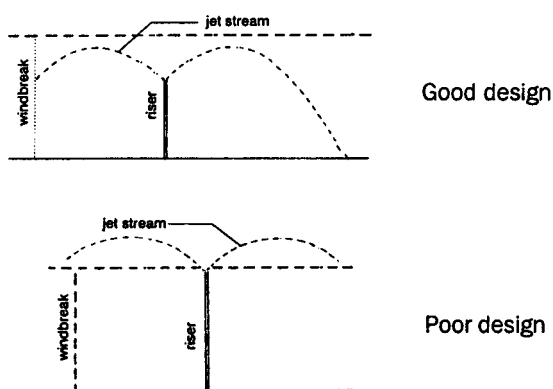

Fig. 3 – Windbreaks should be high enough to protect sprinkler spray patterns

The ability of a windbreak to reduce wind velocity is measured in terms of its porosity. With artificial windbreaks this refers to the openness of the fabric and is measured in percentages. Higher percentages are open and present less obstruction to the airflow and therefore mean less wind reduction. Work needs to be done to test various sprinkler droplet sizes and fabric porosity to achieve minimum distortion.

Porous windbreaks offer the least possible disruption to the air's streamline flow and provide a much larger zone of protection than a solid or very dense barrier which disrupts airflow, creating damaging turbulence and reducing the zone of protection.

Artificial windbreaks are usually erected at right angles to the prevailing wind or along the windward side of the nursery. On level ground this will provide shelter to the leeward of 4 to 6 times the height of the windbreak fence. To calculate the effective shelter a windbreak will provide deduct the height of the sprinkler stream from the height of the fence e.g.

$$\begin{aligned} \text{Sprinkler height} & - 1.2 \text{ metres} \\ \text{Stream height} & - 0.8 \text{ metres} \\ \text{Windbreak height} & - 6.0 \text{ metres} \\ \text{Effective shelter} & - (6.0 - 1.2 - 0.8) \times 6 \\ & = 24 \text{ metres} \end{aligned}$$

Reducing the wind across the plant canopy not only stops the watering pattern from being distorted, but it also greatly reduces evapotranspiration for the plants, so reducing their water needs.

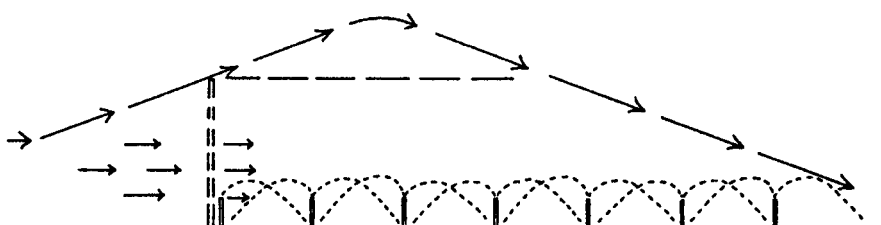

Fig. 4 – A well designed artificial windbreak can protect sprinkler water patterns

Other considerations are as follows:

- The slope of the land in relation to the prevailing wind will determine the protection zone for a windbreak of a given height.
- Ideally windbreaks should be 20 times longer than their height and should extend past the sprinklers or boom and containers at each end.
- Engineering economics dictate that the maximum height of poles must not exceed 6 m, so you may require supplementary breaks through the nursery.

FEATURES

The important features of hand watering are as follows:

- Cheap to install
- Flexible system for a range of plants.

For more info

Water use in the nursery and garden industry – results of the 2006 Water Use Survey. *The Nursery Papers* 2007 No 1

Assessment of hand watering in production and retail nurseries, *The Nursery Papers* 2009 No 1

Hand watering

Hand watering is a common method of irrigation in some 55 % of production nurseries throughout Australia. This practice is perceived by some production nurseries to have several benefits such as enabling the operator to supplement fixed irrigation systems or preventing over watering in low water use areas.

A recent study undertaken by the Australian Nursery Industry indicated not only is the cost of hand watering greater than that of any other irrigation system in terms of equipment and labour costs, it is also an inefficient method in terms of water delivery and use. The study found that hand watering can cost up to 14 times that of an installed overhead sprinkler irrigation system. Even the most expensive capillary matting system, with high initial capital costs, should provide a return on investment after two years purely from labour savings. In terms of labour costs, the cost of hand watering would almost be double that of an automated system and indeed, the labour costs for hand watering will be on-going, and will increase with inflation.

Hand watering is a job for experienced staff only. With this system hose nozzles should be fitted with aerators to reduce water pressure and maintain high volume to minimise disease spread through splash, as well as preventing potting media washing from containers. There needs to be enough aisle space to allow easy access for staff to reach all containers.

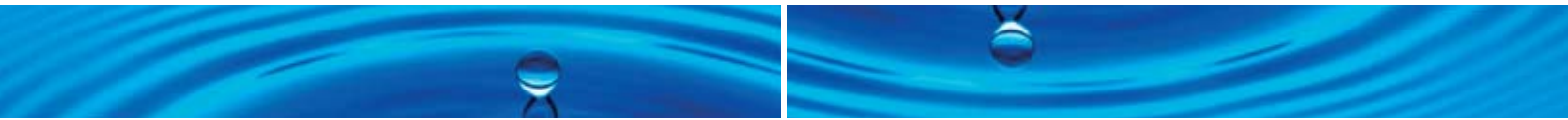

Management considerations

Despite the perception held by some nursery operators, hand watering does not result in even water distribution. Rather, it uses around 40 per cent more water and fertiliser than either ebb and flow or drip irrigation, according to the study in 1994 by J.M. Dole et al., water is applied at much higher rates than the potting media absorption rate. This results in high volumes of leaching and, because experienced staff carry out the task, the labour cost of this system is significant.

Dole's study found that hand watered pots can be expected to produce low quality plants with lower dry weights than either ebb and flow or trickle irrigation systems. Hand watered plants retain the least amount of water when compared to ebb and flow, trickle and capillary mat systems. This is probably due to compaction and forceful flooding top irrigation, loss of medium from flooding the pots, and high application rates. Mix compaction also could decrease aeration and reduce the amount of water available.

Drip Irrigation

Drip irrigation potentially outperforms all other top watering systems in achieving high plant weights with a minimum of water usage. There are, however, products in this category that do not perform to that standard.

Work by Geoff Cresswell (1996) has shown that few commercial growing media es are capable of absorbing water at rates of more than 20 mm/hour from overhead irrigation (see section on maximum MAR for growing medias). The excess water is channelled through non-capillary pores out the bottom. The same occurs with trickle irrigation. A drip rate of one litre/hour is equivalent to 20 mm/hour application rate on a 250 mm pot. Most drippers discharge at 2, 3, 4 or 8 litres/hour.

The common devices that are currently being sold to deliver water to the top of pots in this category include:

- Multi-holed devices
- Spray stakes
- Drippers

Multi-holed devices

These devices will discharge between 10 and 100 litres/hour at wetted diameters of between 0.2 to 2.5 metres. For most applications where all the water is contained in the pot, application rates of over 100 mm/hour can be expected – this is well in excess of the growing media absorption rates leading to excessive leaching.

Spray stakes

These devices have flow rates ranging from 12 to 23 litres/hour. The 12 litre/hour stake will apply water at a rate of 15 – 20 mm/hour over a wetted area of 2.5 m². When this is restricted to the rim of the container then the rate increases dramatically and will range from 70 mm/hour for a 75 litre bag to 400 mm/hour for a 200 mm pot. Higher discharge rates will result in even higher application rates.

FEATURES

The major features of drip irrigation are as follows:

- Minimal runoff of water as it is only applied to the top of the container
- Foliage is not wetted thus reducing disease potential in some crops
- Potentially outperforms all other systems in achieving high dry weights of plants
- Allows excellent control of air-water balance in container to maximise plant growth
- Leaching can be controlled to minimise
- Salt build up in media Can be used to irrigate a wide range of plants and container sizes.
- Unaffected by wind – lengthens watering time
- Can deliver liquid fertiliser providing precise nutrient management
- Provides very even watering
- Precise water placement reduces water use up to 85 % compared with spray or hand watering.

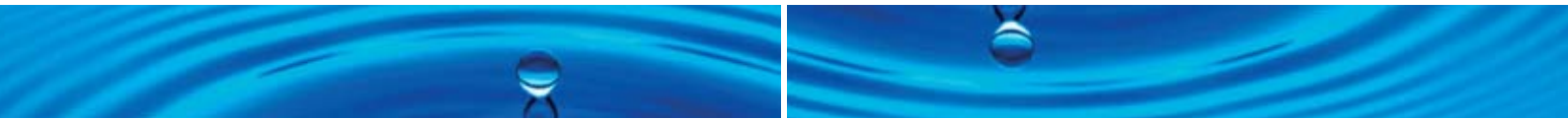

Drippers

As mentioned above, these devices generally have flow rates of 2, 3, 4, and 8, litres/hour and will produce the application rates shown in Table 1.

Table 1 – Application rates (mm/hour) resulting from the use of drippers on different size containers

Container size	Dripper rates in litres/hour			
	2	3	4	8
100 mm	250			
150 mm	110	170	230	
200 mm	60	95	130	250
250 mm	40	61	80	160
300 mm	30	42	60	110
330 mm	20	35	50	90
45 litre	20	27	40	70
75 litre	10	15	20	40

Management considerations

Table 1 shows that most drippers apply water well above the absorption rate of our growing media es. Adding sand and/or wetting agents to bark mixes has been shown to help horizontal distribution of these concentrated applications which may help the absorption rate, but the only way to match the absorption rates is to slow down the flow rate.

This is done by fitting either a 4-way or 8-way manifold to the top of the dripper connected to 3 or 4 mm tubing and arrow drippers.

For smaller containers such as 150 mm and 200 mm an 8-way manifold on a 2 litre/hour pressure compensated dripper will produce 250 ml/hour and 14 and 8 mm/hour application rates/container, respectively.

For larger containers a 4-way manifold can be used and with a 3 litre/hour dripper will produce the application rates depicted in Table 2.

Table 2 – Application rates using 4-way manifolds and 3 litre/hour drippers

Container size	Volume in litres	Number of outlets/pot	Drip rate litre/hour	Application rate mm/hour
300 mm	15	1	0.75	10.6
330 mm	25	1	0.75	8.8
400 mm	35	2	1.5	11.9
45 litre	45	2	1.5	11.9
500 mm	75	4	3	15.3
100 litre	100	4	3	15.3
150 litre	150	4	3	10.6

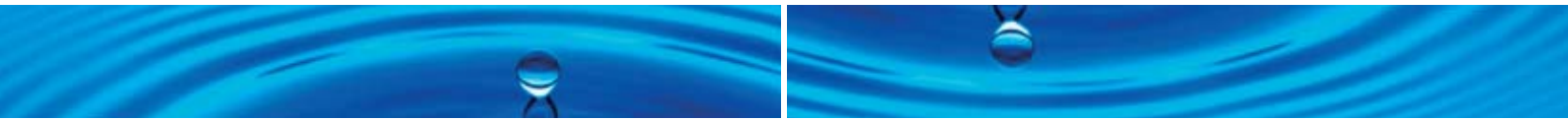

If you wish to use a drip system on smaller containers the select a low discharge rate like 2 or 3 litre/hour that is both pressure-compensated and non-drain. This allows you to pulse the irrigation using a suitable irrigation controller.

For even larger containers it becomes too expensive use this type of dripper configuration and it is better to set up a loop of drip line. Such a system could use 8 mm Netafim Miniscape dripline with dripper centres of 0.5 metres each with a drip rate of 1.9 litre/hour. This can be looped around and joined at a tee with a short length to connect into a normal 13 mm or 19 mm low density polythene lateral. The larger the container, the longer the dripline required and more drippers used.

With this type of product the following application rates depicted in Table 3 can be achieved.

Table 3 – Application rates using Miniscape dripline

Container size in litres	Number of drippers	Drip rate litre/hour	Application rate mm/hour
200	2	3.8	11.4
400	4	7.6	11.4
600	6	11.4	11.4
800	10	19	14.2
1000	10	19	11.4
1200	15	28.5	14.2
1400	15	28.5	12.2
1600	20	38	14.2
1800	20	38	12.7

Where long lines of drippers are to be used it is best to install non drain drippers so that all the drippers start and shut off together which prevents drainage to low point of the lateral and provides a more even application of water.

Low density polythene that is used as lateral pipe will expand and contract with temperature and it is recommended that each lateral line be tensioned to minimise this movement for laterals that are either connected to an overhead wire or laid on the ground. To tension the laterals each end should be fitted with a suitable tensioning core assembly.

BOTTOM WATERING

These systems are gaining popularity in Australia especially with growers whose crops are grown in unprotected cropping systems and for short lines that need to be saleable on a set day like Valentine or Mothers Day.

In a bottom watering irrigation system, the plant’s water needs are supplied by water moving from the system into the growing media via holes in the bottom of the pots and drawn up into the growing media by capillary action.

They can be more expensive to set up than a fixed overhead sprinkler system but they have distinct advantages in that they apply water evenly to a range of container sizes at once and do not water the foliage, thus making them ideal for potted colour and crops susceptible to leaf diseases.

Research and experience has demonstrated that bottom watered crops should be grown with nutrient solutions containing 30 to 50 % less fertiliser than used in conventional top irrigated systems.

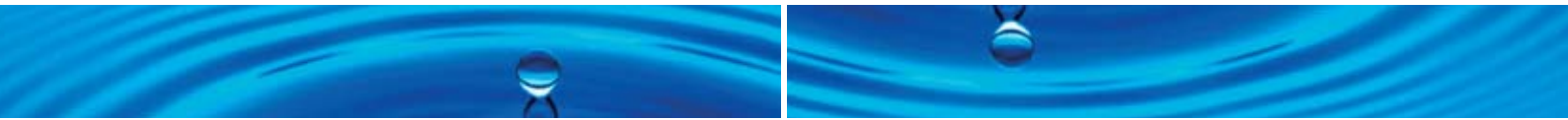

Conventional nutrient ratios are in most cases appropriate.

These systems can offer an ideal Cu and Sc and the MAR is automatically matched to the absorption rate of each mix.

Experience has shown that:

- Continuous water encourages algae growth in the trays and mats and loses too much water in evaporation and drainage. Most operators now water intermittently several times/day.
- Plants watered frequently do not allow the mix to dry out too much so capillary action is easy to maintain particularly in pots over 150 mm diameter.
- 150 mm diameter containers can receive almost the same amount of water through bottom watering as through overhead, although the tops will usually remain dry.
- Deeper pots may require a finer particle medium and more compaction with bottom watering.
- These systems lend themselves well to liquid feeding and water recycling by collecting the discharge in holding sumps. As makeup water is added to holding sumps fertiliser is injected usually to a preset conductivity. The pH is often monitored with an in-line meter and automatically corrected using phosphoric, sulphuric or nitric acid or potassium hydroxide. The nutrient solution should be periodically analyzed for nutrient composition.

FEATURES

The major features of ebb and flow systems are as follows:

- Use the least amount of water of all irrigation systems
- Require much less fertiliser than top watering systems
- Can provide very even water application
- Allow efficient use of liquid fertiliser
- Recirculation of water minimises runoff
- Low risk of spreading pathogens
- No water on foliage reduces foliar pathogens
- Well suited to producing long lines of plants to specified standards.

- Slow release fertilisers and high saline water will accumulate high and very high levels of salt respectively in the top layer on the container which should be flushed out before despatch. If these plants are being grown outdoors then periodic flushing with an overhead system is recommended to prevent salt build up moving into the root zone with light rainfall events.
- Bottom watering systems require reasonably good quality water to avoid salt problems. Many growers in higher rainfall areas will collect rainwater to use as low salinity makeup water. In areas of low rainfall and poor quality water, reverse osmosis (RO) may be required to control salinity. With RO systems it is best to remove salts from the fresh water source instead of attempting to process the recycled water. With RO systems there is the potential problem of brine discharge to consider.

Ebb and flow systems

With ebb and flow systems benches are flooded with water to a depth of about 20 mm. This water is only held for a short time to saturate the bottom of the pots and it then drains from the containers through channels into the drains. To minimise leaching and stop root damage, this cycle should only take 6 to 8 minutes.

Benches are normally graded level and a combined outlet/inlet valve can be installed at each end of the bench. Discharge into the bench should be matched to the flow capacity of the channels so that the water level rises evenly across the whole bench to allow even flood time for all pots. Modular benchtops are available in 1.2, 1.5, 1.8 and 2 m widths and can be set up for various lengths. For benches longer than 5 m it may be best to flood and drain from both ends of the bench.

Although fully automatic systems are available, many operators choose to operate their

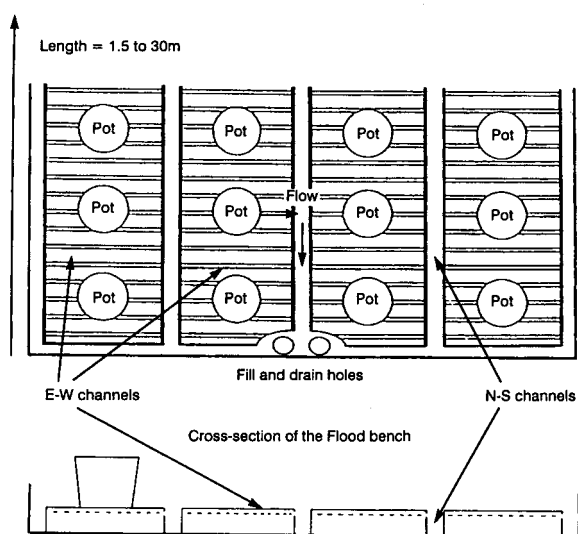

Fig. 5 – Configuration of an ebb and flow (flood) bench (from Greenhouse systems automation, culture and environment)

systems manually so that plants are not over watered or allowed to dry out too much. A simple control on flood level for a manually operated system can comprise a hose clipped to the bench (this introduces the water to the bench) and a small piece of polythene pipe that neatly fits into the outlet (drainage) hole. It is important to take this opportunity to inspect plants for pests and diseases.

A water or liquid fertiliser solution is usually stored in a tank and pumped to the table valve via a flexible hose. When irrigation is finished the remaining solution is drained back down the same pipe and diverted via a return valve back to the tank. The same solution can be used for many irrigations and for many benches.

Management considerations

Generally, all salts not taken up by plants will accumulate in the top 10 to 15 mm layer of the growing media. With salty water, a crust of salt will build up on the surface.

Since ebb and flow systems reuse the water, higher efficiencies can be obtained. Attention must be paid to changes in pH and soluble salt content of the water over time, as well as the potential for spread of plant pathogens.

Oxygen concentrations in circulating solutions are much lower than the optimum level because of microorganism activity in the tank. Some operators are now injecting oxygen into their solutions with some surprising results in improved plant growth.

Usually pH is lower in the lower layer of the pot media. This is caused by nitrifying bacteria and may contribute to nutrient deficiency/toxicity. When using nutrient solutions, bench surfaces and supply equipment (pumps, pipes, tank and valves) should be made of something other than metal or at least coated with a non-metallic surface to stop contamination of the solution with heavy metals.

Before dispatching plants all salts in the top layers of the growing media should be leached out with a thorough overhead watering.

Flood floor systems

There are two systems currently being used. They are concrete floors and sealed gravel floors. We will look at each separately.

Concrete flood floors

A concrete flood floor system comprises concrete floor modules fitted with underground piping that allows water to flood and drain each module rapidly. In most modules the area is split longitudinally into 4 with 2 rows of pipe located a quarter of the distance across the bay from each side. The slope of the floor is peaked at each edge and in the middle of the bay at a grade of 1:100 to 1:150. The longitudinal grade is flat.

A small curb can be used to isolate modules and to locate supports for the shade house or greenhouse. Floors are usually 100 mm thick and suitably reinforced. Floor heating can easily be included in the construction.

Water is held in an underground holding tank and pumped at high flow rates through the large underground pipe into the module through the inlet/outlet holes. After irrigation is completed the water is quickly drained through the same piping back into the holding tank through a media filter to remove growing media and plant debris.

FEATURES

The major features of flood floor systems are as follows:

- Well suited to growing large blocks of plants
- Bottom heating can be incorporated into the floor
- The floors must be built accurately to ensure complete and rapid drainage
- Lower rates of fertiliser required than with top watering systems
- Recirculation of water minimises runoff
- Allow efficient use of liquid fertilisers.

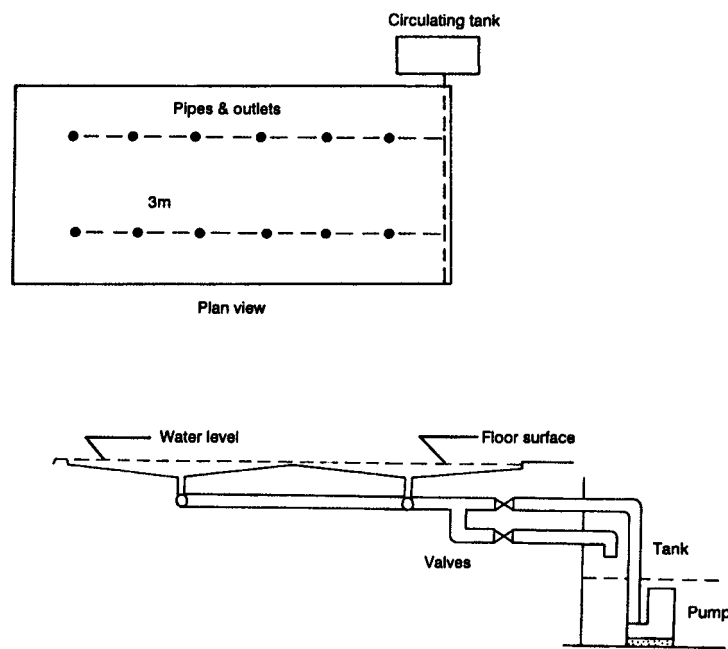

Fig. 6 – A typical arrangement for a concrete flood floor system

Gravel flood floor systems

A gravel flood floor can be constructed using timber edges, 200 micron (0.2 mm) plastic, 50 mm slotted PVC pipe, 20 mm gravel and two hydraulic valves. The floor is sloped at a grade of 1:100 and is initially flooded by opening the inlet valve and closing the outlet valve. After the water level has reached its predetermined height, the inlet valve is closed which opens the outlet valve emptying the bay.

Water is supplied through slotted PVC pipe and the hydraulically operated normally closed (inlet) and normally open (outlet), butterfly valves are located at one end. The size of the pipe and valves will depend on the module size. A full watering and dewatering cycle should take about 15 minutes. When calculating the volume of water that needs to be delivered during each cycle, assume that the gravel area will hold 50 % of its volume as water.

This system will only require low-pressure water delivery and it lends itself to recycling. When irrigation is not required any rainfall is passed through the gravel and out the pipe as the outlet valve always remains open unless the system is activated. By using a 50 mm – 100 mm depth of gravel, sufficient air space is always maintained below the containers to suppress disease and root growth.

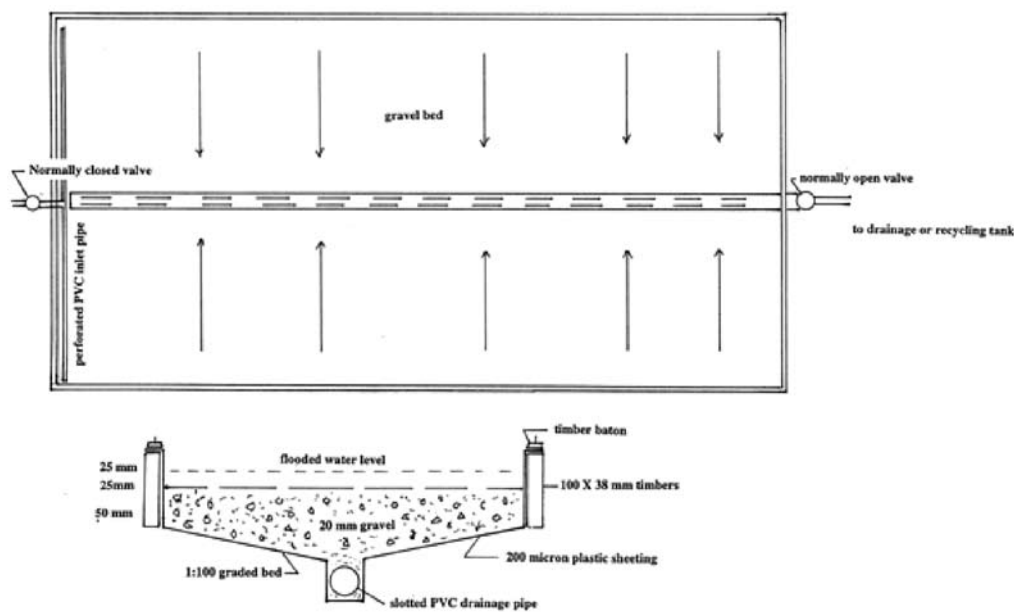

Fig. 7 – Arrangement of gravel flood floor system

Management considerations

Management considerations for flood floor systems are similar to those for ebb and flow systems. It is important that plants have built up a good root system before being put in this irrigation system.

After each crop is removed it is important to thoroughly clean and disinfect the floor.

Trough systems

With these systems troughs sized to suit the containers are laid on a grade of about.

1:600 –1:750 with troughs and pots spaced to suit the plant material. Troughs can be made of either aluminium, PVC or steel painted with a marine paint. Water is supplied at one or both ends at a low rate (use an 8 litre/hour dripper or 1.5 to 2 mm microtubing) and drains to the other end or the centre into a gutter which returns the water to a holding tank for reuse.

The pots in the troughs slow the flow down to allow capillary movement of water into them. The slow discharge into each trough keeps the velocity low enough to stop media washing from the pots. As a guide, 150 mm pots are irrigated for about 20 minutes and 200 mm pots for about 40 minutes, each irrigation. The time between irrigations will depend on the crop being grown and the evapotranspiration rate (water use per day).

FEATURES

The major features of trough systems are as follows:

- Allow retro-fitting of existing bench layouts
- Allow excellent ventilation between plants
- Lend themselves to plant stacking to better use space
- Excellent control over water efficiencies.

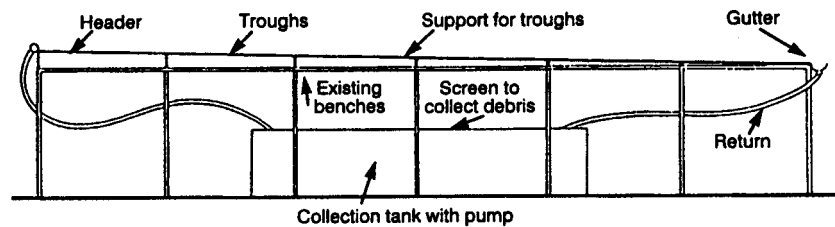

Fig. 8 A typical arrangement of a trough bottom watering system

This system allows good airflow between the spaced troughs, reducing the humidity that can be a problem with other bench bottom watering systems. Many growers also use steel roofing, particularly when growing potted colour. This has all the advantages of a trough system except the additional airflow. These systems both lend themselves to liquid fertilizing in the irrigation water and a closed system similar to that described in the ebb and flow section.

Other features of ebb and flow and flood floor systems also apply.

Management considerations

Salt levels in the top layer of the growing media will be high and pH values in the bottom layer will be low with trough systems so the same precautions need to be taken as with ebb and flow and flood floor systems. Essentially, similar management is required for these three systems.

Treatment of irrigation water used in this system to minimise the spread of pathogen diseases is warranted. Care needs to be taken to disinfect the water supply before it is introduced into the system. Disinfecting the water through, say, a slow sand filter before recycling it would be an advantage. It is important to use disease free stock with this system.

Capillary mat systems

Mats for capillary systems are usually made of synthetic fibrous material like carpet underlay or geotextile fabric from 2 to 6 mm thick. Commonly, black polythene film is laid on a flat bench, and the matting is then put on top of the polythene and covered with perforated plastic sheet. This arrangement is very flexible and in production areas it can be used to cover bench tops or laid out over prepared flat areas either inside shade or poly houses or outside in the open.

The matting is kept constantly wet by applying water, usually through a low volume discharge system like drip tape (the tapes are placed about 60 cm to 2 m apart). Higher discharge driplines are spaced at the wider spacing's. There should be enough water outlets along the pipe to maintain the whole mat at the same moisture content which is also dependant on the thickness of the synthetic fibrous material that carries the water.

Keeping the growing media at a constant moisture content will dilute the soluble salt effect. Black perforated cover sheets will control algae growth better. Pots must have enough drain holes in the base to start and maintain the capillary action. It is usual to top water to help start this capillary action.

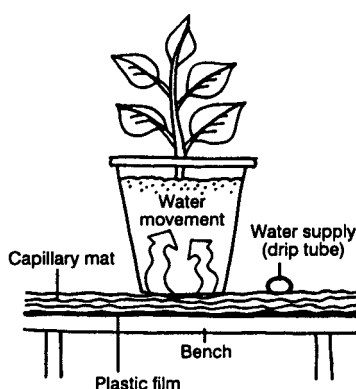

Fig. 9 – Capillary matting efficiently moves water into containers

Management considerations

Water is supplied to plants as a result of it moving through the capillary pore spaces in the growing media. It is important to select a growing media that can quickly take up water by capillary action.

Experience has shown that:

- Pots with a diameter of 150 mm can receive almost the same amount of water through bottom watering as overhead although the tops will usually remain dry
- Pot sizes over 150 mm diameter are very difficult to overwater with bottom watering but plugs and flats are easily overwatered and can rapidly become saturated.
- High moisture levels in pots over 150 mm diameter must be maintained otherwise they may become difficult to re-wet.
- Taller pots may require finer sized particle medium and more compaction with bottom watering.

FEATURES

The major features of capillary mat systems are as follows:

- Efficient systems where light levels and temperatures are low and humidity is high
- Well suited to short crop cycles like potted colour
- Water level in containers remains constant
- Different plants and pot sizes can be laid out on the same matting.

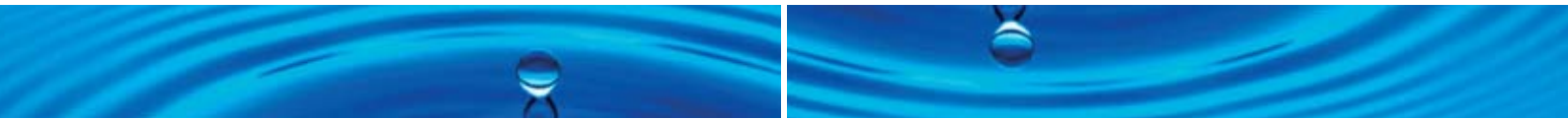

Growing media salt levels, runoff salt levels and nitrate concentrations tend to be higher in capillary systems than any other system.

Capillary systems also use more water than other bottom watering systems and require more irrigations. Evaporation from the mats, accentuated by the often used black perforated plastic top covering, contributes to water loss and is responsible for the high growing media and runoff salt levels compared with other bottom watering systems. Overall water needs decrease as the canopy cover closes in and the mats become shaded.

To stop salt buildup many operators top water every 3 to 4 weeks and often incorporate a fungicide.

Liquid fertilisers can produce algae problems in capillary mats. These systems usually use less than half the fertiliser of overhead systems with 40 % leaching.

If capillary systems are being used outside then rain is an obvious problem, especially with high intensity storms. Light rain could move the saline top layer in pots into the rootzone which could severely affect plant growth.

In capillary systems the excess water around pots can cause the spread of rotting fungi such as rhizoctonia. Applying fungicides and principles of sound crop hygiene such as wider plant spacings may alleviate this problem.

Sandbed capillary systems

With sandbed capillary systems pots are placed in a moist sandbed which is usually constructed by filling a watertight bench with a minimum of 25 mm of sand. Many operators make the sandbed thicker (from 75 to 100 mm) with the saturated level 25 to 50 mm below the surface. The surface of sand beds needs to be dead level but the bottom can be sloped, e.g. 1-in-70, to help remove excess water. A water system should automatically provide water so that the surface sand remains moist but not saturated.

FEATURES

The major features of sandbed capillary systems are as follows:

- Probably the cheapest of all subirrigation systems
- Similar features to capillary mat systems.

A typical system would comprise a bed lined with 0.2 mm UV-protective plastic film incorporating plastic drainage pipes to remove excess irrigation water and an overflow pipe at one end to remove rainwater. The plastic and drainage pipes would be covered with 100 mm layer of sand with typical grain sizes as follows:

>2 mm	25 %
0.6 to 2 mm	30 %
0.2 to 0.6 mm	30 %
0.6 to 0.2 mm	15 %

Normally 40 to 50 % of the sand by weight should be between 0.2 and 0.5 mm. In higher rainfall areas a coarser sand may be needed to help drainage and stop surface saturation. Handreck and Black's book, *Growing Media for Ornamental Plants and Turf*, contains a test for sand to determine its suitability for capillary systems. Sand should also be thoroughly disinfested to ensure it is disease free before use.

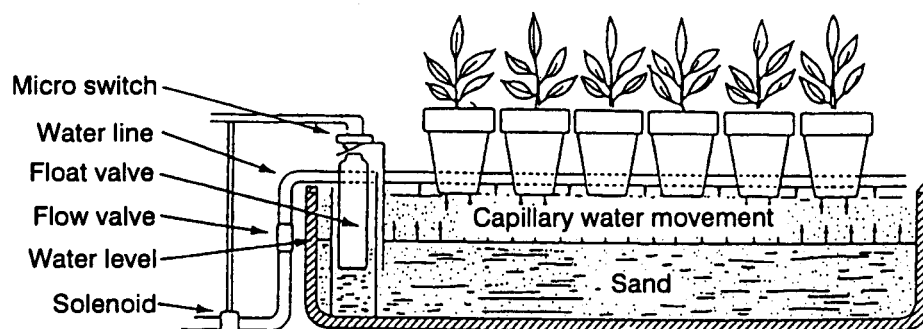

Fig. 10 – A sandbed capillary system arrangement with automatic water level control

Management considerations

Pots larger than 9 L are not adequately watered on capillary sandbeds.

The growth of roots through pots into the sandbeds is a management problem which must be addressed for most species that grow on beds for longer than 2 months. Some operators use a plastic cover. In such cases pots need to be pressed well into the sand to maintain capillary action.

Liquid fertilisers can produce significant quantities of slime in the sand. Care should be taken when designing systems for outside in high intensity rainfall areas to prevent the sand from washing during storm events.

Other management considerations detailed in capillary mat systems also apply to sandbeds.



IRRIGATION CONTROLLERS

How efficient and flexible your irrigation system is to manage may depend on the control equipment you choose.

Irrigation controllers are used to start and turn off an irrigation operation (cycle). Automatic irrigation systems are divided into blocks or banks of sprinklers, bottom watering or emitters that are turned on and off by either solenoid or hydraulic valves. The flexibility of an irrigation system and how precisely it applies the right amount of water at the right time is dictated by the controller that operates these valves.

Management considerations

When installing a controller it is important to select one that has the features that are important for your operation. Some of the features that may be useful to incorporate into a nursery system may include:

- Being able to easily combine and change valve groupings to match plant water requirements or turn off empty areas. Stations can easily include two or three valves per station.
- Allowing for the number of start times you want. You need to decide how many you want e.g. 10, 20, 30 or more.

FEATURES

The major features of irrigation controller systems are as follows:

- Combine and change valve groups
 - Enable you to select the number of start times you want
 - Multi program stations
 - Select run times to suit operation
 - Adjust program daily
 - Include manual operation
 - Backwash filters
 - Inject fertiliser
 - Control pumps
 - Operate disinfection systems
 - Protection, fault reporting, system diagnosis
 - Can be connected to a computer.
- Whether cyclic water is required to either maintain humidity or to cool plants in hot weather. Sensors can be connected to activate this feature. Controllers with multi-programming functions can have one program for, say, maintaining humidity and another to supply the water requirements, both to the same area using the same valves.
 - How would you like your run times configured i.e. in hours, minutes or seconds? What are the minimum and maximum run times you require? Many controllers can provide between 1 second and 99 hours to precisely match your requirements.
 - How easy is it to adjust your programs? Some controllers will allow you to increase or decrease all watering times as a percentage of those set, so that on an extra hot day you may wish to increase all programs by, say, 30 % or in overcast conditions you may wish to reduce the watering times by, say, 50 %. This can be done with one switch. You can also include a rain switch to turn off outside stations after a set amount of rain has fallen while keeping the indoor areas on the irrigation schedule.
 - Include a manual operation switch to allow you to stop or start programs.
 - Use a controller to backwash filters, inject fertiliser, control pumps and operate disinfection systems. Other features that are readily available include on-off key and pause function, password protection, electronic short circuit protection, battery backup, alarm to alert malfunction, lightning and power surge protection, self diagnostics, fault reporting, usage reports on, say, monthly water applied per station. Some controllers can be either directly connected to a computer or indirectly via a modem to allow centralising control and data processing.

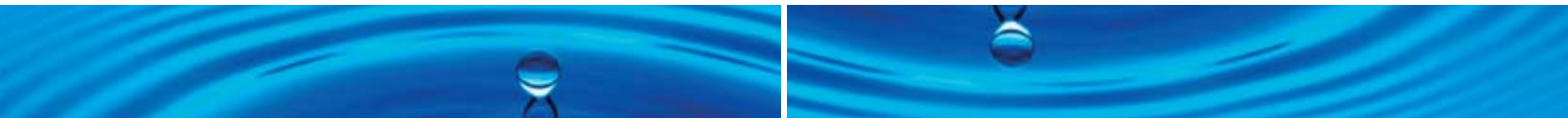

IRRIGATION SYSTEM DESIGN

There is real economic benefit in having an efficient system that can operate within your management constraints. Designing an irrigation system is not all about pumps and pipes – it is about plant water requirements, management constraints and watering evenly. These are the nursery operator's domain.

Once you have worked out the important things, a good irrigation designer can crunch the numbers and prepare an efficient design, so the system works for you, not the other way around.

So your irrigation system should reliably apply enough water evenly to meet all the plant needs in the time available.

- Applying water evenly requires a well maintained hydraulically sound system with application rates matched to growing media absorption rates
- Applying the right amount of water requires knowledge of plant water requirements over the growing cycle.
- Time available needs to take into account the constraints of the site and business.

Planning an irrigation system

Planning, designing, installing, operating and maintaining nursery irrigation systems is a team effort. This team will include the nursery owner, production staff, irrigation designer, equipment suppliers and system installers. This process starts and finishes with the nursery owner and production staff, as it is their business, they are the experts in what they produce and their future bottom line is dependent on the successful operation of the system.

The irrigation designer will be able to size the pipes, pumps and select the correct valves and filtration equipment, but they will have little knowledge of your plant water requirements or the management constraints of your business and how they relate to the operation of the irrigation system. So you will need to develop an irrigation plan to present to the designer.

Many production nurseries have several growing conditions that may require different or specialised irrigation and water management decisions. Some examples of these might include:

- propagation
- seedling trays
- greenhouses and igloos
- shade areas
- large pots or bags
- hanging baskets
- fixed and rolling benches
- specialised lines like potted colour or spring promotions
- hardening areas
- inground parent material.

Within these divisions there may also be other subdivisions of pot sizes, plant varieties, plant water use etc. which can be dealt with by block management.

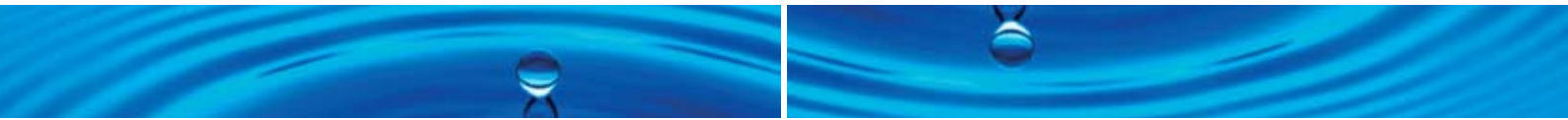

Check the most suitable type of system for you to use in each area. There is no reason why you cannot combine several system types in the one nursery. Some examples that you could consider may include:

- Mistings or fog systems and separate controls for the propagation area.
- Drippers for tall or large foliage plants, large containers, hanging baskets, flowering plants or plants susceptible to fungal diseases.
- Low application rate sprinklers with fine droplet sizes for seedling trays, ferns and indoor plants with possible thermostat control.
- Capillary matting or ebb and flow systems for potted colour and single sale lines.
- Overhead irrigation with impact sprinklers for the outdoor stock.
- Inverted micro sprinklers for shade houses and areas with rolling benches.
- Mobile boom for bedding plants, seedlings and tube stock.
- Trough system for flowering plants or plants susceptible to fungal disease.

Let's look specifically at various types of systems and the detail you will have to consider so that the irrigation designer can prepare a design that matches your business requirements.

Overhead systems

You will need to consider:

- The layout and shape of each area so that the appropriate sprinkler spacing may be selected taking into account spacing of support posts and windbreaks.
- Upright or inverted sprinklers to be used and the riser or dropper heights to select threaded rigid poly risers screwed into PVC faucet take-off adaptors will allow easy change-over to adjust height to suit different crops.
- The MAR that best suits the growing media's absorption rate and crop being grown.
- The type of sprinkler, diameter of coverage, distribution pattern, height of jet stream and operating pressure.
- Wind conditions likely in each area and the best method of minimising this effect.
- Computer printouts of MAR, Cu and Sc for each spacing and sprinkler selected. (Set up four sprinklers on the spacing and recommended pressure and measure their performance and assess their suitability for your requirements. Waterwork workshop will show you how).
- The location of laterals, submains and risers. Control heads with valve and pressure tappings (buried or above surface) to allow easy access and be protected from damage by normal nursery operations.
- Sprinkler location to reduce Sc values.

Mobile booms

You will need to consider:

- Will you use the boom to just irrigate or also to apply fertiliser, fungicide and pesticides?
- What range of application rates and boom travel speeds do you require to meet the range of plants over their whole growing cycle?

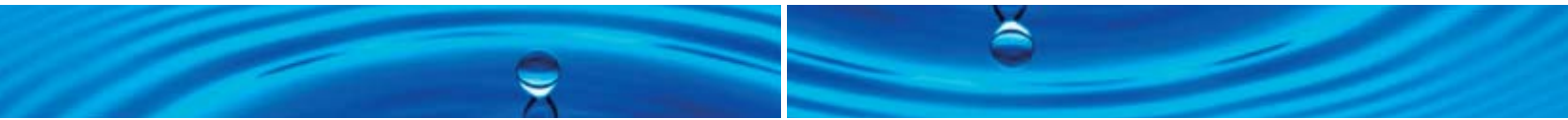

- Does the boom need to irrigate in both directions and do you require proportional applications by automatically varying the speed?
- What are the water requirements of the plants and what frequency do they require irrigation?
- What operating pressures do each nozzle set require and how will this be regulated?
- Will you require the option to raise or lower the boom height to maintain that fixed watering height to grow plant production runs of different heights?

Slow discharge drip systems

You will need to consider:

- Range of container sizes to be watered so that dripper rates and number of dripper stakes/ container or length of drip tube can be determined.
- If pulsing is required to match application rates to the growing media absorption rate.
- Time needed to apply water to each section (remember this system can operate during windy conditions and will not interfere with staff duties).
- How many drippers are required, what is the discharge rate and pressure required?
- If you will be liquid feeding, what arrangement do you want at the control head of each block?
- If the dripper laterals will be located at ground level or elevated along a wire between rows?
- How you intend to space the containers in these areas so that the drip system is set up to create minimum interference to you as you shift containers in and out of the area?

Bottom watering systems

You will need to consider:

- Frequency and cycle time of each water application.
- Flow rates that will match uptake rates of growing media.
- Line pressure to deliver the required flow rates to each system.
- If water will be recycled or run to waste?
- What type of fertilising system will you adopt?

General requirements for all systems

Having selected the best systems for your needs and budget you now need to assess for each of these systems:

- The type of water quality required and how you can achieve this through pretreatment.
- The most suitable water disinfection treatment to remove plant pathogens.
- The level of automation that suits the management needs and budget constraints.

- The total number of hours the irrigation system will operate in summer and whether this matches your management and site constraints.
- What arrangement of pumps are required in the pumping stations, would a variable speed system best suit your needs, what back up facilities do you need in the event of any pump break down or power failure?
- Pressure tappings to set and check the pressure of each block, the shut off head of pump, head loss across filters and pump operating pressures.
- Protection and control equipment for the pumping unit.
- How will the water recycling system marry into the scheme?

These are decisions that need to be made by the owner/manager and production team before an irrigation designer can set about and complete their section of the plan.

The information that you have collected and the decision you have made from the above criteria will allow the **Irrigation Designer** to:

- Hydraulically design pipe sizes, control valves, filters and pumping duties.
- Prepare a list of equipment that will be needed to complete the system.
- Prepare plans and drawings to show positioning and arrangement of equipment and specification that meet all your requirements.
- Be called on to independently assess the installation or verify its adequacy.
- Comment on alternative arrangements or equipment proposals suggested by equipment suppliers and/or installers.

The irrigation company and contractors can now:

- Prepare a quotation for the supply and installation of the equipment.
- Supply and install the equipment once accepted by you.
- When installed check the system meets your requirements by operating and taking all necessary measurements and checks, comparing them with those specified by you and the designer. Set all block pressures then measure, calculate and record the MAR, Cu and Sc for each block. Measure and record the shut off head of the pumping equipment.
- Clarify maintenance and warranty periods prior to acceptance.

Make sure you discuss any suggested changes, additions or modifications with your designer prior to acceptance and installation.

Maintenance plan

The nursery owner and the production staff with assistance from the irrigation company and designer need to drawn up a maintenance plan to:

- Meet the service requirements of the pumping equipment. Each component has its own maintenance requirements and must be inspected and serviced regularly to maintain the operation of the original installation. Obtain a copy of the manufacturer's operation and maintenance guide book for each of the components (e.g. pump motor, filter and control equipment).

- Maintain filters and valves in accordance with manufacturers' recommendations.
- Check operation of sprinklers/emitters for both discharge and pressure and assess replacement needs.
- Set protocols to check water quality of irrigation and runoff water, fertiliser concentration in leachate and leachate volume.
- Prepare protocols to set and check disinfestation system performance and monitor chemical use and concentrations.

FURTHER READING

Capillary mat maintenance of plants in the retail nursery (journal), Schuch, U.K.; Kelly, J.J. and Teegerstrom T. (2008), *Horttechnology* 18:250–255

Economics of five irrigation technologies for container-grown *Viburnum odoratissimum* (journal), Haydu, J.J.; Beeson, R.C. and Caron, J. (2004), *Acta Horticulturae* 664:309–315

Market analysis of the capillary mat irrigation technology for wholesale nurseries in the Southeastern United States (conference proceedings), Hodges, A.W. and Haydu, J.J. (2001), Proceedings of the Southern Nursery Association Research Conference, 46:570–573

Managing nursery runoff (book), Creswell, G. and Huett, D. (Eds) (1996), NSW Agriculture, Horticultural Research and Development Corporation, and Nursery Industry Association of Australia, Wollongbar

Managing water in plant nurseries (book), Rolfe, C.; Yiasoumi W. and Keskula, E. (Eds) (2002), NSW Agriculture, Orange

Review and assessment of hand watering in nurseries (report), Poulter, R. (2009), Lifestyle Horticulture Products & Services, Horticulture & Forestry Science, Department of Primary Industries & Fisheries, Brisbane, Queensland

Review and assessment of hand watering in nurseries (report), Poulter, R. (2009), Lifestyle Horticulture Products & Services, Horticulture & Forestry Science, Department of Primary Industries & Fisheries, Brisbane, Queensland



2 IRRIGATION MANAGEMENT TOOLS TO ENSURE MORE PRODUCTIVE AND EFFICIENT USE OF WATER

Efficient water management will depend on your irrigation system selection and design but it also depends on the day to day management of water on your nursery. This in turn will have a large impact on the profitability of your business.

The last 10 years have taught us that water and energy are the two items that warrant attention. Water, because it has or is becoming a limited resource and energy as its cost is substantially increasing.

Another significant factor that has become evident from nurseries that have undertaken improvements in water management is the lift in moral of the staff which in turn improves individual productivity and the bottom line.

If each water user is to be held accountable for their management of this diminishing resource, then more attention needs to be given to measuring and record keeping. This will not only improve your water utilisation but it will have a bearing on the quality of your plants and increase your dollar returns.

If you wish to become more efficient and improve your plant quality while saving dollars it is fundamental that you need to know the vital details of your system's performance as well as details on average water use, water costs, pumping costs, maintenance costs or hand watering labour costs, plant throw out percentage etc. If you haven't measured these aspects of your business how are you going to improve the management?

To manage irrigation efficiently, several practices need to be considered starting with an understanding of growing media management.

GROWING MEDIA MANAGEMENT

Modern growing media used in container nurseries are made from a range of soilless materials which include pine bark, sawdust, peat and peat moss, rice hulls, coir fibre as well as sand, ash, perlite and vermiculite.

When selecting a growing media for a particular aspect of nursery production, it is important to consider the method of irrigation you are going to use.

For bottom watering systems, you need a growing media with good capillary wetting properties. Although peat is useful for improving the water holding capacity of a mix, its capillary wetting capacity is generally poor. Coir fibre, on the other hand, is extremely easy to wet up in this way and would be a useful addition to growing media where bottom watering is used.

Wetting agents

Wetting agents are surfactants which promote wetting by reducing the surface tension of water. This allows the water retention to be increased without decreasing the air filled porosity.

They are available in a granular or liquid form. In container nurseries the granular form incorporated into the growing media will last longer for container plants and the liquid form is useful to improve water holding characteristics for growing media blends that have become difficult to wet up.

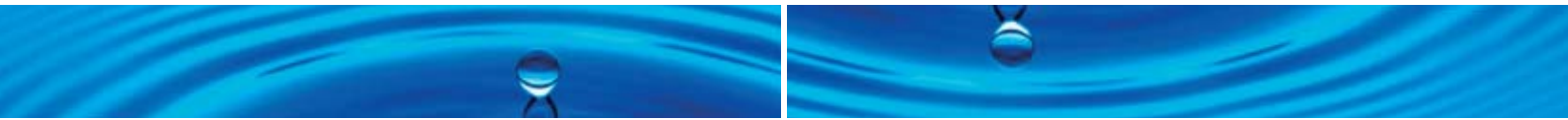

This product has been found particularly useful in both peat and sawdust based growing media as both an aid to rewetting dry growing media blends and to aid drainage in waterlogged mixes.

Refer to manufacturers directions for application rates.

Designing a growing media

When making up a mix, your main concern should be the physical properties of the growing media components. That is their size, shape, density and the way they pack together. These physical properties determine the proportion of air and water in the growing media when drained as well as the bulk density.

Air filled porosity

Air filled porosity (AFP) is a measure of the free air space in a growing media which has just drained from a saturated state. Air filled porosity is important as this affects the ability of air to diffuse in and out of a growing media, which is required for good plant growth.

A growing media with a low AFP may need watering less often than one with a high AFP, but it can easily become waterlogged, resulting in slower plant growth. High AFP growing media need watering more often but can produce more rapid plant growth.

An AFP in the range of 10 – 15 % maybe suitable for plants that are either slow growing or likely to receive little attention once planted out. Most nurseries aim for an AFP in the 15 – 20 % range. For nursery stock in the open in high rainfall areas, 20 % is an absolute minimum.

Container capacity

A growing media's total water holding capacity (referred to as container capacity) is the amount of water held by the growing media (by weight) following irrigation and initial drainage. In pots, immediately after drainage has stopped, the mix at the very bottom of container remains saturated and the level decreases to be the least at the top.

The amount of water held will depend on the particle size and the AFP. In general, the higher the AFP percentage the lower will be the water holding capacity. Readily available water is mainly held in particles between 0.1 – 0.25 mm. Water held in finer particles is generally unavailable to plants as it is held too tightly. This point is commonly referred to as the refill point and is a significant percentage of the water held in growing media. Particles of larger size tend to hold air.

The height of the saturated and very wet medium for a given growing media is generally the same, however is influenced on the type of container. For example, a growing medium in a shallow container will have a higher average water content (and a lower AFP) than the same growing medium in a taller container. This is why some shallow containers become saturated under bottom watering systems that supply water continuously.

Different mixes respond differently as shown in Table 3.

Table 3 – Water capacities and availabilities for various growing medias

Some typical mixes	Container capacity	Refill point	Available water
1 – 85 % pine bark, 15 % sand	41 %	30 %	11 %
2 – 70 % pine bark, 15% sand, 15 % coir	43 %	31 %	12 %
3 – 85 % pine bark, 15 % coir	48 %	33 %	15 %

If your irrigation system is working efficiently by applying water evenly at a rate that can be absorbed by the media then the following table details the maximum water applications required to fill a pot from refill point to pot capacity.

Table 4 – Maximum refill water applications

Pot size	Pot volume	Required irrigation in mm		
		Mix 1	Mix 2	Mix 3
100 mm	500 ml	7	7.6	9.5
112 mm	1.0 L	11.2	12.2	15.2
125 mm	1.05 L	9.4	10.3	12.8
140 mm	1.5 L	10.7	11.7	14.6
150 mm	2.0 L	12.5	13.6	17
165 mm	2.4 L	12.3	13.5	16.4
180 mm	2.8 L	12.1	13.2	16.5
200 mm	4.5 L	15.8	17.2	21.5
250 mm	8.1 L	18.2	19.8	24.8
300 mm	13.5 L	21	22.9	28.6

If you had this range of containers all in the same irrigation block then the 100 mm containers would dictate the irrigation amount and frequency if all the plants had similar water requirements. There would be little point in applying more than 7 mm at any one time using say Mix No 1 (85 % pine bark, 15 % sand).

For more info

Container Media Management (report), Bodman, K. and Sharman, K., (1993). Contact Nursery & Garden Industry Queensland, Brisbane, Australia for a copy of this report.

Water absorption rate

The ability of a growing media to absorb and retain water from a top watering irrigation system cannot be reliably predicted from wettability, AFP, bulk density, water holding capacity or any other properties specified in the current Australian Standard for Potting Mixes AS3743-2003.

To determine the approximate absorption rate of your mix, follow the simple field test procedure outlined in *Managing Water in Plant Nurseries* (pages 89–92).

Recent work in Queensland has determined the maximum MAR for their most common mixes as detailed in Table 5.

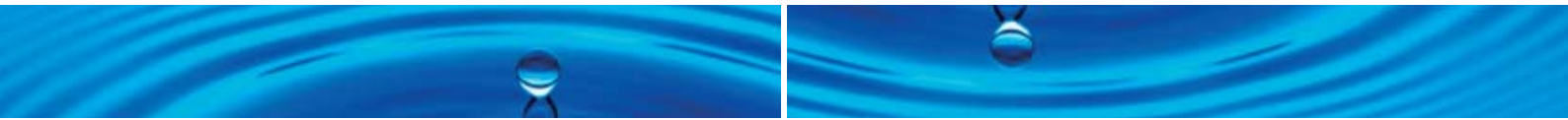

Table 5 – Maximum MAR for various growing medias

Growing media components	Maximum MAR
Pine bark 85 % & sand 15 %	10mm/hour
Pine bark (100 %)	10mm/hour
Pine bark 85 % & sand 15 % & wetting agent	15mm/ hour
Pine bark (100 %) & wetting agent	15mm/ hour
Pine bark 75 % & sand 15 % & coir 10 %	20mm/ hour
Pine bark 50 % & coir 50 %	20mm/ hour

WATER AUDIT

For those nurseries that already have an irrigation system and currently manage this and other water issues, a water audit will measure and record what actually happens on the nursery and provide valuable information on where improvements can be made and on what priority each of these needs to be given. Operators that carry out this valuable process find many of their assumptions of what is going on are completely different to reality.

This water audit will fall into the following categories.

Water sources

Water quantity – detail the availability of water from each source, note limitations, costs, reliability backup supplies etc.

- Storages – demonstrate how the sizing of the storages relates to the irrigation demand.
- Bores – What is the sustainable long term pumping rate and what is the seasonal variability of the standing water level, detail depth, aquifers, casing size, screens etc.
- Drainage water is it collected or disposed? What are the limiting factors in recycling or reusing this water?
- Town water supply or stream pumping how are the costs escalating and how is the security holding up.

Water quality

Check on the quality of your irrigation and drainage water sources.

- Have samples tested in a laboratory for pH, electrical conductivity (EC), Alkalinity, Chloride, Hardness, Nitrates, CaCO₃ saturated index, Sodium Absorption Ratio (SAR), Calcium, Magnesium, Sodium, Potassium, Aluminium, Arsenic, Boron, Copper, Iron, Manganese, Molybdenum, Sulphur and Zinc and any other tests (i.e. turbidity for UV disinfestation).
- Have these tests analysed for the suitability of this water to grow your range of plants, irrigation equipment clogging hazard and disinfestation limitations.



Production requirements

Note any limiting factors from irrigation that effects optimum production. This could include:

- Irrigation times match your production schedules
- Irrigation times minimise wind effects on sprinklers
- Plant disease susceptibility with excessive wet foliage
- Staff working schedules (i.e. dispatch and spraying)
- Off peak power or water periods
- Excessive use of water
- Excessive leaching of nutrients
- Uneven plant growth
- Slow plant growth
- Leaf drop, giving a less attractive product
- Poor inter-node spacing and plant shape
- Excessive drainage
- Elevated or contaminated watertable.

Irrigation system

A full evaluation of the current irrigation system and current irrigation management practices should be undertaken. This may require the services of a qualified irrigation specialist for some of the analysis. You and your staff can do much of the legwork collecting data on the sprinkler performances and operating pressures of blocks and pumps.

Pumps

- Details of each pump should be taken noting the operating pressure at each irrigation station. Your local irrigation equipment supplier should be able to provide you with a pump curve for each pump. The irrigation specialist will advise on the suitability of each pump for the range of duties required and can measure/calculate the flow to each station and the range of efficiencies the pump is working at.
- Shut off pressures should be recorded on all rotodynamic pumps and compared to pump curves to check impeller wear.
- Suction losses should be measured and calculated to check efficiency of pumping system.
- Detail the maintenance schedule for your pumping units.
- Energy costs to run these pumps should be recorded for each season. This will indicate how efficient your pumping systems are at present.

Filters

- Note the type and size of filter units. Irrigation specialist can comment on type and capacity of the unit and how it suits your requirements.
- Record the back flushing frequency and what maintenance you carry out on this unit.

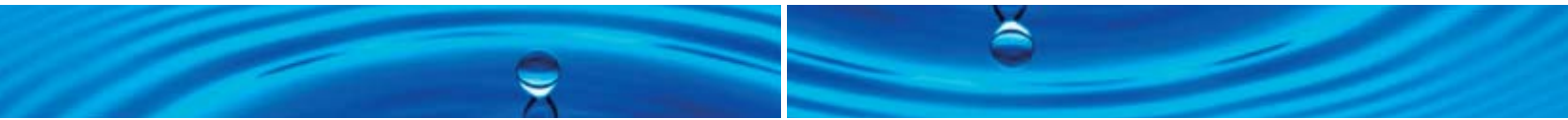

Sprinkler/dripper performances

- With a series of catch cans measure and calculate the MAR, Cu and Sc for each irrigation block, noting the operating pressure, types of sprinklers/drippers and spacing. A Waterwork Calculator and procedures to follow to measure sprinklers can be found in the Waterwork course.
- Draw up your current irrigation schedule for each block including the block area and your daily irrigation timings with whatever season variations you normally adopt. How does this match your crop water requirements?
- Record how you currently decide on how long to water each block.
- Outline your maintenance schedule and how you monitor the system performance (pressure, output etc.).

System hydraulics

- The irrigation specialist can check the hydraulics of the system and comment on the adequacy of the pumps, piping and valves and suggest any changes that are required.
- Do you flush and disinfect your pipelines. If so, detail how and at what frequency.

Energy audit

Irrigation, recycling and water transfer pumps are a significant proportion of most nurseries energy cost. Reassessing the efficiency of your pumping units can provide a considerable saving. One of the most recent innovations in pumping that is particularly suited to production nurseries is the packaged pressure systems that consist of two or more pumps in parallel and can combine variable speed and fixed speed pumps. These systems give nurseries the flexibility to irrigate anything from a small polyhouse to several hectares of production. The key is they only use the energy required to meet the specific duty. This can provide substantial savings in electricity where you have great variability in your pump duties.

An irrigation specialist should be able to assess the energy usage for your current range of pump duties and suggest improvements.

Drainage/recycling and management

An evaluation of the current drainage and recycling system and current drainage management practices is every bit as important as the irrigation system (See Chapter 4).

Existing drainage system

- Describe in general terms the drainage system detailing the types of drains used and comment on their adequacy in heavy rainfall.
- Show how you manage drainage to minimise downstream pollution. Detail any sections of the current system that need attention (e.g. erosion, ponded water etc).
- Does your drainage system match the slope, soils, and rainfall intensity as detailed in Waterwork course?
- Does the system meet all necessary state and local regulation?
- What is your recycling/reuse options? How are they managed?
- Does the quality of stormwater runoff from your nursery meet local environmental guidelines?

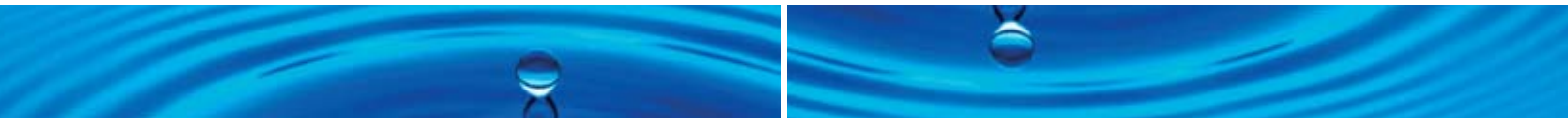

Drainage storage

- Show how you manage your drainage storages to optimise water retention and minimise return of any pollutants in the water to surface and groundwater systems.
- Demonstrate that the storages are located on suitable sites to minimise losses through seepage.

So what do you do with all this information?

This auditing process will highlight the limitations and opportunities for optimising efficient water utilisation on your nursery. The changes will fall into two categories:

- Management changes
- Technological changes

Management changes

When you have assessed how much water you apply to each block each day and match this to the actual water requirements of these blocks you may need to reorganise your irrigation schedule.

Maintenance of the irrigation equipment and drainage system may need to be upgraded.

Technological changes

If your irrigation and/or drainage system needs significant upgrading, list out the requirements for modification or replacement. This list can be a brief to the designer.

Draw up a plan of action

The nursery industry has developed a Nursery Production Economic Model which is a decision model utilising a series of economic spreadsheets for the nursery industry to assess proposed changes to a business in regard to water saving technologies to allow growers to plan and implement water use efficiencies based on a return on investment. The details to run this model are provided at Appendix 2 – Input data for Nursery Production Economic Model.

It will also provide estimates on other operational cost savings such as reduced electricity cost, plant throw outs, fertiliser and chemical usage. Contact your local Nursery Industry Development Officer for assistance with this model.

From the results of the model and water audit the nursery can prepare a timetable for implementing the development/upgrade with a summary of costs and returns anticipated.

- Describe any new scheduling system you may now use.
- Outline how you will monitor the irrigation system for performance (pressure, output etc.).
- Outline how you will manage drainage to maximise reuse and minimise downstream pollution.
- Outline how you will manage drainage storages to optimise water retention and minimise the return of pollutants to surface and groundwater systems.
- Give each change a priority in terms of water use efficiency benefit and cost or regulatory requirements and briefly explain why you have given this priority.

Once these changes have been fully costed then this information can form the basis of a business plan for your friendly financial institution to finance the upgrade.

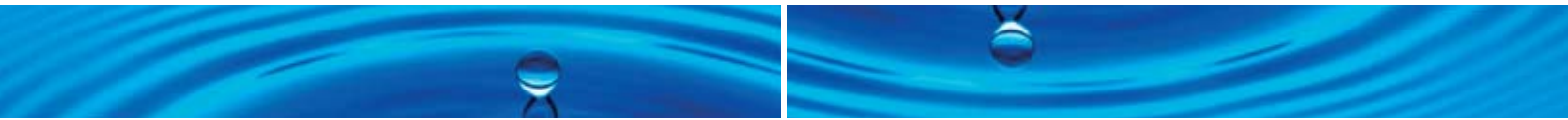

This process will also demonstrate to the catchment authorities or environmental regulators the responsible approach your business has taken to improve water utilisation and minimise the impact your business will have on the local environment.

It will also reduce downtimes, better meet the water requirements of your plants and improve your productivity and profitability.

Nursery retrofit case study

This nursery had 1.2 ha under production and had been in operation for several generations with a 15 to 20 year old irrigation system installed as the nursery grew over generations.

Performance data pre-retrofit was Cu 66 to 91 %, MAR was excessively high at 14 to 51 mm/hr and the Sc ranged from 2.1 to 5.0.

Under the old irrigation system, the maximum daily water use varied from 48 kilolitres per day during winter to 98 kilolitres per day during summer. This equated to a total water use ranging from 22 megalitres to 26 megalitres per year, with water provided by a dam.

Post retrofit, performance data and water use has significantly increased. The Cu has increased and ranges from 88 to 93 %, MAR has reduced lowered and ranges from 8 to 17 mm/hour and the Sc has stabilized and ranges from 1.03 to 1.4.

The retrofit has provided annual water savings of 6.5 megalitres, a reduction of 27 % from the previous system. Water and operational costs savings of approximately \$831 per year have also been achieved.

A map of the nursery with the new and old water use efficiency values for the different irrigation zones is shown below.

For more info

Upgrading an irrigation system can improve water uniformity and reduce your operating expenses. *The Nursery Papers* 2008 No10

A generic economic decision model for the nursery industry to assess proposed changes to a business. *The Nursery Papers* 2008 No 11



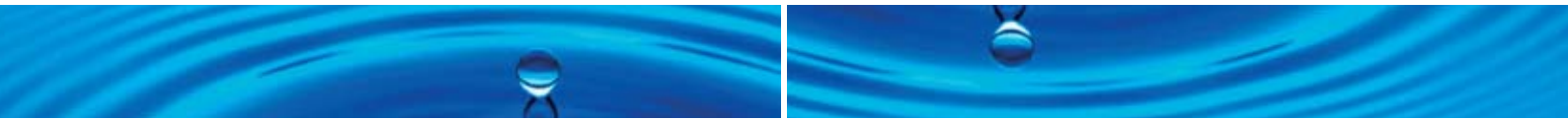

IRRIGATION SCHEDULING

Irrigation scheduling is generally explained as ‘applying the right amount of water at the right time’. Most plants use more water on hot sunny days than cool overcast days and different plants require different amounts at different stages of production. Unfortunately many nurseries just water to keep their plants alive. This often means that the plants with the highest water use or most frequent demand dictate how the whole nursery is irrigated.

In nurseries that grow a range of woody ornamentals water use has been measured and the daily water use for similar sized plants in the same sized containers under identical conditions can vary by more than 300 %. Add to this the range of container sizes the development stage of the crops, variations in growing conditions (shade etc) as well as the climatic conditions that create up to a further 300 % daily variation in evaporation in summer.

Many nurseries simply apply a scheduling system by setting a watering regime for summer and winter ignoring all these variables. This approach to irrigation scheduling leads to:

- Excessive use of water.
- Excessive leaching of nutrients.
- Poor plant growth.
- Leaf drop, giving a less attractive product.
- Poor internode spacing and plant shape.
- Saturated pots covered with algae and moss.
- Excessive drainage with elevated nutrients.
- Elevated or contaminated water tables.

All of these results will affect your bottom line because nutrients and water are interrelated. Plant growth depends on the management of nutrients, which in turn depends on your management of water.

The whole system of water use is driven by transpiration at one end and available water at the other end. The amount of water used by a plant depends on the solar radiation, temperature, wind and humidity. If there is not enough water available, or if it becomes too hard to extract from the growing media, then the metabolic process starts to close down; the plant stops growing and becomes overheated and starts to wilt. If this is occurring on a regular basis then the bottom line is being affected by poor plant growth and too many throwaways.

Plants in the open, exposed to full sunlight and wind will use more water than plants under shade cloth, where solar radiation, temperature and wind are all reduced. Plants in poly or glass houses can experience higher temperatures and humidity, but are exposed to less radiation and wind, so they will generally use less water than plants outside in summer. However, the opposite could be the case in winter.

With a range of plants using different amounts of water throughout their growth cycle, a range of growing conditions (outdoor, shade, poly house etc) and daily variations in potential evapotranspiration some measurements need to be taken and recorded.

The four key measurements are:

- Water holding capacity of the growing media.

For more info

Scheduling irrigation to maximize efficiency. *The Nursery Papers* 2006 No 008

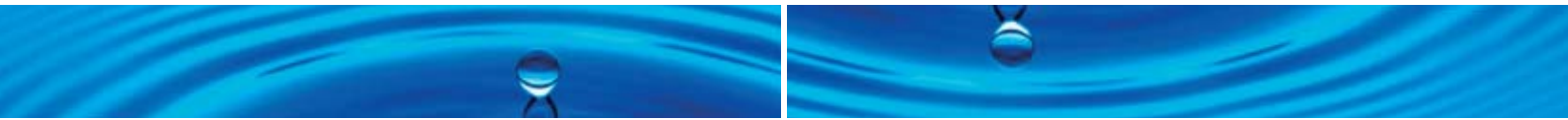

- The daily evaporation at the nursery.
- How much water do the plants use.
- The application rates of the irrigation system.

Growing media – readily available water

How is water held in containers?

Water is held by surface tension in the small pores of the media called micro-pores. The water held in the larger pores, macro-pores, generally drains out providing the air porosity. The smaller pores are referred to as capillary pores and will move water into the mix under bottom watering systems. The larger pores filled with air are called non-capillary pores.

Underneath topsoils are subsoils and underneath pots is air. This makes a very big difference in the amount of water held in just drained media in pots (container capacity) as would be the case in just drained soil (field capacity).

The water holding capacity, air filled porosity and absorption rate of your mix will have a great bearing on how you irrigate your plants as noted at the start of this chapter.

Measuring daily evaporation

There are many automatic weather stations now available that will calculate this figure and provide it on a daily basis

Alternately you could install a Class A evaporation pan and read the previous days evaporation first thing in the morning before setting the irrigations for the day.

Measuring actual plant water use

There are many tools to measure soil moisture for in ground horticulture. Container grown plants using artificial media provide some challenges for many soil moisture monitoring tools. Capacitance tools seem to have the most promise but care needs to be taken as some are affected by high temperatures that occur in pots and will provide false readings in high EC solutions. These tools need to be calibrated to the growing media and refill points determined for the range of plants being monitored.

In 2007, the nursery industry conducted research into soil moisture sensors in a containerised production environment. The project aimed to identify whether soil moisture sensors are appropriate for use in a containerised production environment and to evaluate the effectiveness of soil moisture sensors for irrigation scheduling in organic based growing media.

There are a variety of soil moisture sensors available:

- 1) Insertion units (monitoring tool) with moisture, temperature & EC
 - Simple, quick, requires little technical experience.
- 2) In-situ units (monitoring or automation tool)
 - Technical experience needed to install.
 - Can be connected to irrigation controller.
 - Generally more expensive.

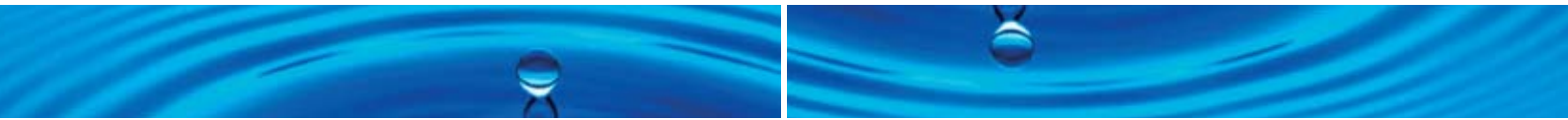

The research looked at five soil moisture sensors and set about identifying the right soil moisture sensor to use with the criteria being:

- Size of sensor – the sensor needs to fit into growing containers (numerous types of containers being used, i.e. tubes, 100 mm diameter pots and upwards).
- Type of sensor – volumetric or soil potential sensor and be robust and provide reliable data.
- Cost – should be financially viable for smaller nursery operators.
- Availability – should be readily available with after sales technical support.
- Simplicity/ease of use – can be installed and maintained by the nursery staff.
- Interface/connection – the product can be connected to existing irrigation controllers.

The results of the trials suggest the soil moisture sensors tested can be used to either monitor or automate the irrigation system to improve water use efficiency in comparison to timed and/or deficit irrigation. The tangible benefit here is reduced leaching and hence the opportunity to preserve the overall water storage if water recycling systems are not installed to manage run off and preserve water budget.

A more simple method is to weigh plants before and after irrigation. Some simple measurements taken at various stages of plant development will give you a handle on the range of water requirements across the nursery.

For more info

Do soil moisture sensors have a role in containerised nursery production? *The Nursery Papers* 2008 No 8

Select the size of the container and the plant that is going to dictate the irrigation frequency for each block. Weigh a representative sample of these pots (containing plants) that have received the average application rate for these blocks, after you are confident that the containers are at their maximum water holding capacity. Before you next irrigate, weigh the same containers to determine the water (weight) loss. Table 6 provides you with the weight loss for a range of container sizes for each millimetre of water required to replenish the container.

Remember that – one litre of water weighs one kilogram.

If you know the MAR and S_c of the system for each block then Table 6 will match the irrigation time to the water requirements.

Table 6 – Equivalent weight loss for one millimetre of water application

Container size (mm)	Weight loss (grams)
80	5
100	10
150	20
170	25
200	30
250	50
300	70

Take for example a 200 mm container that is irrigated in a block that has a MAR of 9 mm/hour and a S_c of 1.3 to water the driest pot in the block. The container weighs 4,460 grams after rain or irrigation. Just before applying the next irrigation it now weighs 4,280 grams.

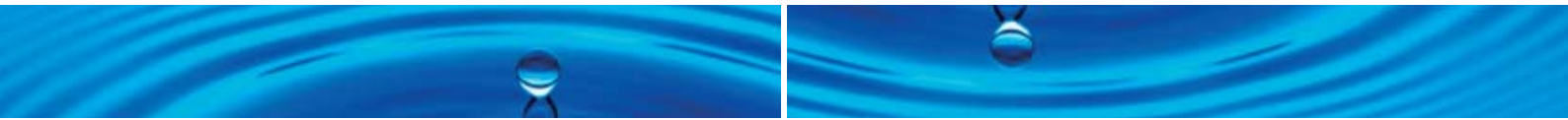

The water loss is 180 grams (4,460 – 4,280) which is equivalent to 6 mm (180÷30 taken from Table 6).

$$\begin{aligned} \text{Time to irrigate} &= \frac{\text{application} \times 60 \times \text{Sc}}{\text{MAR}} \\ &= \frac{6 \times 60 \times 1.3}{9} \\ &= 52 \text{ minutes} \end{aligned}$$

If plants within the block you have measured have either high volumes of leachate or no leachate and the application rates are similar, it illustrates that these plants have a different water requirement and should be moved to a more appropriate block. Initially this could be as simple as high water users, low water users and the rest.

Carrying out this procedure over the full range of plants in the nursery will allow the staff to split the crops into water requirements rather than pot size or what ever system you currently employ. This can be converted to a crop factor so all water requirements can be connected to the daily evaporation reading. For example in a given day of an evaporation reading of 5 mm one plant may use 4 mm and another 8 mm the crop factors for these two crops would be 0.8 and 1.6, respectively.

In time as plants are potted up they can be located in their appropriate irrigation block where you can apply the right amount of water at the right time.

Water requirements

Crop requirements can vary greatly in container nurseries. When plants are freshly potted up the bulk of the water use is via evaporation from the pot surface. As the plants grow this surface is shaded reducing the surface evaporation but this is then offset by the increased plant water use. If the canopy area is about the same as the surface area of the top of the container then the crop factor will average about 1 for plants with moderate water requirements. Some plant varieties will use more than this while others will use less.

If the canopies are allowed to grow substantially larger that the container surface area then the crop factor will increase rapidly and will be a function of the canopy area. For example if the canopy diameter is 500 mm and the container diameter 300 mm then the crop factor will be 2.8.

Water requirements are going to vary each year depending on effective rainfall, evaporation and stages of plant growth and plant species. A long term average annual water requirement is usually based on a crop factor of 1, the effective rainfall of 20% and using the decile 5 monthly rainfall figures.

To determine an average annual water requirement for irrigation it is necessary to look at average monthly evapotranspiration rates of the plants and subtract the proportion of this requirement that could be expected to be supplied by the median rainfall (decile 5). The shortfall is what can be expected to be applied as irrigation. These factors are all measured as depth of water in millimetres. To convert these depths to a volume it is necessary to multiply this depth in mm by the area being irrigated in square metres to arrive at a volume in litres which can be converted to megalitres.

The methodology of water requirement calculations using the above data is explained in NGIA workshop, Waterwork (Module 1: Water supply, treatment and disinfestation).

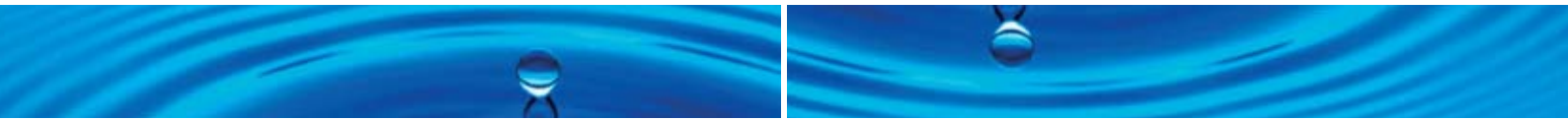

FURTHER READING

Increasing adoption of innovative irrigation technologies in Australian nurseries (report) Hunt, D. (2008), Lifestyle Horticulture Products & Services, Horticulture & Forestry Science, Department of Primary Industries & Fisheries Queensland

Growing media for ornamental plants and turf 4th edition (book), Handreck, K.H. and Black, N.D. (2010), University of NSW Press

Managing water in plant nurseries (book), Rolfe, C.; Yiasoumi, W. and Keskula, E. (Eds) (2002), NSW Agriculture, Orange



3 INCREASED RE-USE OF NURSERY WASTE WATER TO REDUCE BUSINESS DEMAND ON THE WATER RESOURCE

A number of major Australian nurseries recycle water successfully. The success of these enterprises, whose products range from advanced trees to seedlings, is based on careful monitoring of water quality, inputs of high quality water to improve quality of their waste water, and treating water to minimise pathogen spread.

It is essential to monitor and treat nursery waste water as its quality varies greatly. For instance, storm runoff from roofs is generally of high quality and usually does not need disinfection while the quality of runoff from roads and paths is not as high because of oil contamination and road base colloids. This is especially so if these roads and paths are not sealed, which increases the risk of plant disease spread.

Water collected from production areas is even poorer in quality because it often contains nutrients, floating potting media constituents, humic acid and agricultural chemicals. It may also contain plant pathogens. To make it suitable for reuse this water may have to be pretreated to remove contaminants such as litter, silt and plant pathogens, or it may have to be acidified. Because water from production areas comes mainly from irrigation drainage it is good practice to manage irrigation and fertiliser application so that runoff and nutrient leaching are kept to a minimum (see Chapters 1 and 5).

To maximise quality of irrigation runoff, production areas should be covered with plastic (at least 200 micron (0.2 mm) thickness) which is covered with screenings or aggregate and overlaid with weed mat. Different water collections can be kept separate or blended to produce a supply suitable for recycling onto production areas or for reuse for other purposes.

Finally, it is important to note that although legislation is in place regulating the disposal of some nutrients and agricultural chemicals into the environment, the water policies of most State/Territory environment protection agencies are continually being reviewed.

REUSING NURSERY WASTE WATER

This publication recommends three alternative uses of nursery waste water:

- reusing it for other purposes including garden and pasture irrigation
- recycling it back onto nursery stock
- disposal to the environment.

The first two alternatives are discussed in this chapter while disposal is dealt with in Chapter 4.

Reusing nursery waste water for purposes other than nursery production

There are several ways of reusing nursery waste water for purposes other than nursery production.

Crop production and fertilisation

Using waste from nurseries for other crop production (if there is enough land available), and pasture and garden irrigation is a good practice to use up excess nutrients that may otherwise be released to the environment. If you do consider this option, remember that some nutrients will accumulate in the soil unless they are removed from the site by harvesting.

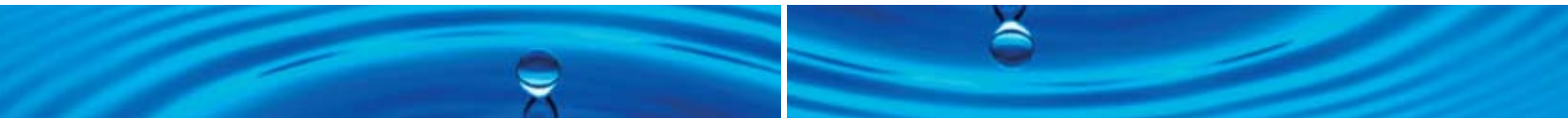

The quality of water for reuse for other plant production need not be as high as for container plant production and disinfection is unlikely to be necessary. Nevertheless, the quality limits for irrigation water as outlined in the following section on recycling should be followed if possible.

Wetlands

Constructed wetlands are designed to mimic natural wetlands, while maximising the performance of those aspects of natural wetland systems that are known to improve water quality. Put simply, by controlling and manipulating water flows, including retention time (to allow for sediment and nutrient trapping) and depth of water, wetland functions can be optimised.

Just how effective wetlands are, especially as far as their ability to address the full range of water quality problems as well as their limitations are concerned, has been the subject of much controversy. Constructed wetlands can, however, be effective in achieving things such as improving water quality, creating habitat for native fauna, and providing an environment for passive recreation and community education.

Their limitations can be reduced and their effectiveness enhanced or optimised through the use of multi-objective design based on a greater understanding of wetland processes. More research is needed into these processes to develop better guidelines.

Constructed wetlands can be divided into those where the water flows over the surface of a ponded area where water plants are present (often called surface flow wetlands or free water surface wetlands) and those where water flows through a substrate material which supports water plants (often called subsurface flow wetlands).

Deep dams

Although it has not been confirmed experimentally, deep dams containing enough organic matter may promote anaerobic conversion of nitrates to nitrogen gas.

Recycling water onto production areas

Table 7 lists the limits for all key factors for plant production in the nursery as far as water is concerned.

Many of the essential plant nutrients occur in useful levels in nursery and flower farm waste waters, and these industries could save on the use of fertilisers by recycling water and reusing the nutrients.

For more info

Water quality survey of the Australian nursery and flower industries (report), Beardsell, D. and James, L. (1995). Technical Report for HRDC Project No. NY 320

Nutrient levels vary greatly at different nurseries and at different times of the year so regular monitoring and good management are necessary to maintain the quality of recycled water at an acceptable level.

If you do adopt this strategy be aware that daily fluctuations occur in nutrient content of leachates in nurseries depending on irrigation and fertiliser practices, especially after liquid feeding. As well, in a yearly production cycle, water quality should be monitored at least at the following times:

- soon after potting on
- once during winter and summer
- once during dry or wet periods.

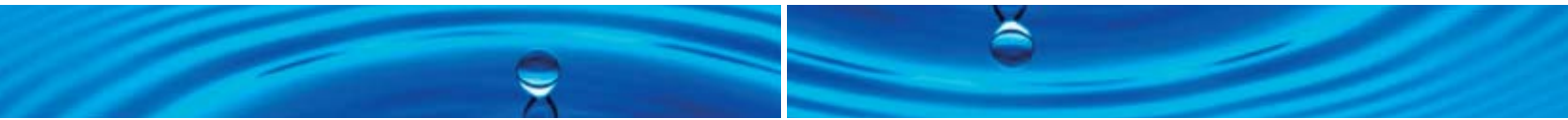

It is essential that you measure electrical conductivity, pH and nitrate when recycling water onto production areas. Other factors including sodium, chloride, bicarbonate alkalinity, phosphate, boron, manganese, aluminium, iron and copper can also be regularly monitored if they are likely to be a problem at individual enterprises.

Note that water to be recycled may also contain residues of plant protection products. See Chapter 6 for more information.

Water pretreatment

Water to be recycled onto nursery stock needs to be pretreated to improve quality and assist in eliminating plant pathogens. Procedures to consider are clarification, filtration and storage.

Clarification

Turbid water can be clarified with flocculants such as aluminium sulphate, ferric alum and gypsum. Ferric alum is effective in the pH range of 5.5 to 8.5, and aluminium sulphate in the pH range 6.8 to 7.5. These chemicals lower the pH of the water so monitoring this factor before and after application is essential. To clarify water use alum at 0.5 to 0.75 kg per 10,000 L of water. Gypsum can be used at a rate of 3.5 kg per 10,000 L. Mix these chemicals with water before applying them. They are best used in storage tanks.

Filtration

The filtration method you use will depend on the quality of water to be recycled. If the water contains large amounts of silt and other solids it may need pretreatment with a hydrocyclone filter.

Before disinfestation and recycling, the following filter grades should be used: media filters containing 1 mm crushed basalt, disc filters of 120 – 140 mesh, and automatic disc filters of 150 – 200 mesh. In addition, an 80 mesh filter is preferable to a 120 mesh filter after a disc gravel filter.

Increasing the filtration grade of the automatic filter within the range listed above will protect the check filter better, but will also increase the backflushing frequency. A low pressure differential for activating the flushing works more efficiently. Increasing the filter grade causes more backflushing than reducing the pressure differential.

When using gravel filters it is better to use smaller filters such as 6 x 20 inch rather than 3 x 36 inch filters. When backflushing the excess is delivered through five filters instead of two. Grade 1 crushed basalt is nominally 1 mm in size (0.7 – 1.5 mm). Two millimetre is too coarse. The gravel will take about 2 months to bed itself in. If the water is very dirty, the velocity of discharge will have to be decreased.

Storages

To minimise the demand of the business on water, collecting part of the runoff will have many benefits, including being less reliant on other water supplies. Water collected is free, and storm water runoff from buildings and hard areas is often of better quality than existing sources. To calculate the size of storage required, determine the area to be drained in square metres, the amount of rainfall (in millimetres) per time period and the amount of irrigation per time period.

Drainage volume (litres) = (area m² x rainfall mm) + (area m² x irrigation mm)

Example

For 2,300 m² of nursery area in Castle Hill in northwest Sydney during the wettest month of the year (March, 120 mm), this rain falls in 11 days so irrigation is necessary for the other 20 days of the

month (20 days @ 3.5 mm/day = 70 mm).

$$\begin{aligned}\text{Drainage volume} &= (2,300 \times 120) + (2,300 \times 70) \\ &= 276,000 + 161,000 \\ &= 437,000 \text{ litres in the wettest month}\end{aligned}$$

For a storage to meet this capacity it would have to be as an air space in the storage coming into the wet month.

Storages can be built as excavated tanks with all the storage below ground, or as a turkey nest with aboveground storage that can be replenished with a large flood lifter pump. Turkey nest storages use less earthworks. If water is collected mainly from clean catchments such as roofs, the storage should be plastic lined to maintain quality.

Small nurseries may be able to use concrete or poly tanks, depending on the amount of storage required. Some nurseries, such as those on flat land or on sand, may not be able to drain to a single storage area. Sumps such as septic tanks with small pumping units matched to the runoff discharge and controlled by two level float switches can be put in series. The runoff can then be moved to a main storage using polythene or PVC piping. Guidelines for building storages can be found in the publication *Managing Water in Plant Nurseries* available through State/Territory nursery associations.

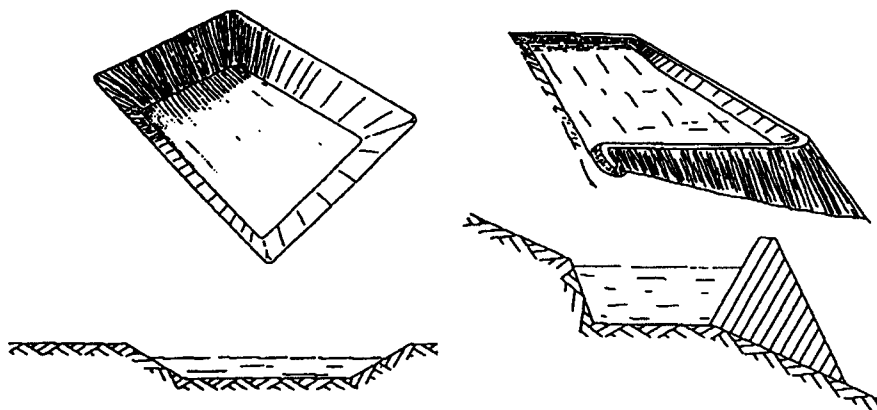

Excavated storages

Hillside storages

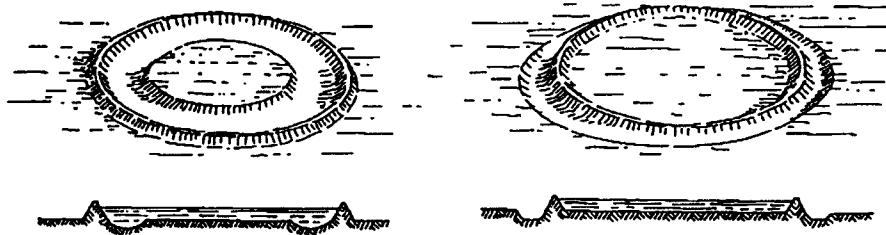

Ring tank storages

Turkey nest storages

Managing nitrate, phosphate and potassium for recycling

One management issue when recycling nursery water is algal growth on dams. Bluegreen algal blooms occur at low concentrations of nitrate and phosphate. Between 10 and 100 mg/L nitrate-nitrogen accompanied by phosphate with a nitrogen:phosphorus ratio of between 16 and 20:1 has been known to cause outbreaks.

Controlling algae with chemicals such as copper salts may be hazardous when recycling because they can accumulate to potentially phytotoxic levels. In storages chelated copper products such as Coptrol®, when used strictly as instructed on the label, have been found to give good results. Algae can also be controlled by manipulating nitrogen and phosphorus levels in water, for instance by removing nitrogen by adding straw bales or other materials with a high carbon to nitrogen ratio to water supplies.

Useful potassium levels are found in recycled water. Potassium application could be reduced by as much as 20 per cent with water recycling.

Table 7 – Nutrient and other factor levels in irrigation water for general ornamental plant production.

Based on Hart (1974); Ayres and Westcot (1976), Aikman (1983), Degremont (1991), Yeager et al (1994), Bienbaum 1993.

Factor	Phytotoxic limits
Nitrate (as NO ₃ not N)	<100 mg/L (excessive soft growth)
Phosphorus (as phosphate)	<15 mg/L for phosphate sensitive plants
Iron (Fe++) (Yeager et al)	5 mg/L
Copper	0.2 mg/L
Boron	0.3 mg/L
Zinc	2.0 mg/L
Manganese	0.2 mg/L
Aluminium	5.0 mg/L
Molybdenum	0.01 mg/L
pH (nutrient imbalances)	5.5 to 7.0
Salinity (EC–dS/m)	0.75 to 3.0 (low to severe problem*)
Chloride	200 mg/L
Sodium	100 mg/L
Alkalinity	40 to 500 mg/L CaCO ₃ (low to severe problem)

* Safe salinity limits will depend on the type of crops grown. The optimum levels of nutrients in irrigation water will also vary with the crops grown. Refer to hydroponic texts for guidelines.

For more info

Managing water in plant nurseries (book), Rolfe, C.; Currey, A. and Atkinson, I. (eds), (1994) NSW Agriculture, Horticultural Research and Development Corporation and Nursery Industry Association of Australia

For more info

Water quality survey of the Australian nursery and flower industries (report), Beardsell, D. and James, L. (1995). Technical Report for HRDC Project No. NY 320

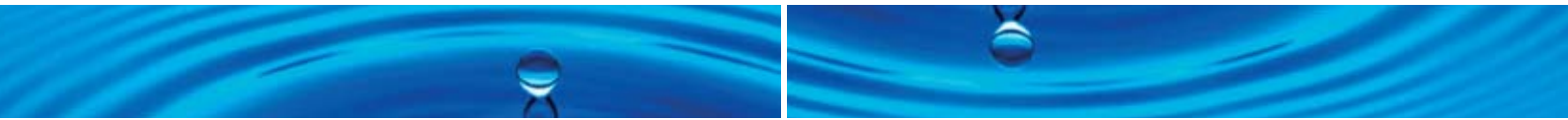

For more info

Draft irrigation and fertilisation Best Management Practices for producing container grown woody environmental plants (booklet), Yeager, T.; Fare, D.; Gilliam, C. and Niemiera, A. (1994), University of Florida

Managing salinity

The key to managing high salinity in recycled water is having a source of low salinity water to mix with recycled water. In some nurseries where water is recycled, salinity is not a problem because of the availability of high quality mains water and because runoff, including rainwater, is collected.

As a guide, an electrical conductivity (EC) of above 1 dS/m indicates a salinity problem in unused water. If the water is low in sodium and chloride (balanced hydroponic solutions can have an EC of over 2 dS/m) higher ECs can be tolerated.

Chloride is also toxic to plants, especially at concentrations above 200 mg/L. For this reason keep chloride levels below 200 mg/L in recycled water, although with good management higher levels can be tolerated depending on the crops grown.

Sodium should be kept below 100 mg/L in recycled water, preferably with a sodium absorption ratio (SAR) below 5. Levels of sodium higher than 100 mg/L can be tolerated if other cations are in balance.

Managing pH and alkalinity

The ideal water pH level for plant growth is from 5.5 to 7.0, although levels from 5.0 to 8.0 can be acceptable depending on the crops you are growing and the amount of buffering of pH in the water.

Recycled water with a pH too high for safe chlorination will require acidification.

Acidification is an easily automated process for which commercial units are available. There are several options to do this and each option has its advantages and disadvantages. Be aware of the following:

- when disinfecting recycled water by chlorination pH must be below 7.0.
- hydrochloric acid increases chloride levels and phosphoric acid may cause excessive phosphorus levels, however, if chloride levels in water are not already high, hydrochloric acid is the easiest to use.
- sulphuric acid is the safest to use in plant terms but not in terms of operator safety.

Alkalinity is a common problem in nurseries in South Australia and other areas where bicarbonate levels over 100 mg/L of calcium carbonate equivalents to pH 4.5 are regularly encountered. Lime or dolomite need not be used in potting media irrigated with water with an alkalinity higher than 100 mg/L CaCO_3 . Seedling nurseries are especially vulnerable to increases in pot media pH when irrigating with water with high alkalinity levels.

Calcium and magnesium

A survey of recycled water in Australian nurseries conducted in 1995 (Beardsell and James) showed that waste water in contained useful levels of both calcium and magnesium. Excess calcium can induce magnesium deficiency if the latter nutrient is lacking.

Other nutrients

Useful levels of sulphur, iron, manganese, copper, boron and zinc can be found in nursery waste water.

In fact, all of these nutrients, except sulphur, can reach toxic levels and may need to be monitored in certain cases (this is why some are regarded as pollutants by environment protection agencies).

Table 7 lists the limits for each of these micronutrients. Levels higher than these can be toxic to sensitive

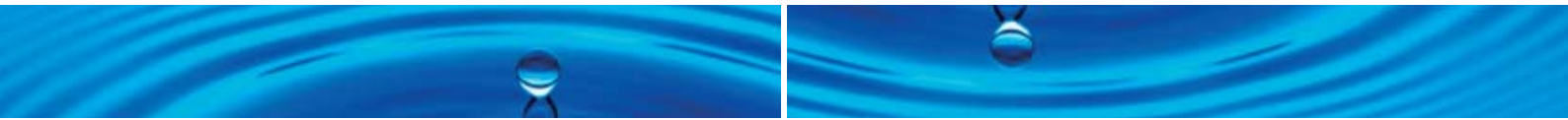

crops. As an example, high copper levels can occur in runoff water if copper compounds are used to control algae on paths etc.

Fluoride

Fluoride ions are toxic to some plants, especially in the Liliaceae and Marantaceae families. Reticulated water contains 1 mg/L fluoride, just below toxic levels for these two groups of plants. It also occurs as a contaminant in some phosphatic fertilisers. Several nurseries have been found to have high levels of fluoride in their waste water, some of which would have been from bore and other water sources.

Herbicides and other agricultural chemicals

Herbicide and pesticide residues may be detected in runoff water at nurseries, and may build up in storages that collect this water. For more information see Chapter 6.

Disinfection chemicals

Chlorine (as available hypochlorous acid) is toxic to some plants at levels above 5 mg/L. Unfortunately there are no reliable published figures on the phytotoxic levels of chlorine dioxide, hypobromous acid and other bromine compounds. There is some data on ozone phytotoxicity, but this relates to photochemical smog damage. Using disinfectants such as Biogram® in poorly ventilated glasshouses can damage sensitive crops such as ferns.

Colour, turbidity and ultraviolet (UV) transmittance

For most nursery purposes, colour and turbidity of water are not problems unless they cause spotting on leaves, thus reducing market quality. Ultra violet transmittance of water, which is related to water colour, is important if using UV radiation to disinfect it. For successful UV treatment water should have a UV transmittance of at least 50 % (at 254 nm) which relates to colour of less than 30 hazen units.

Handling agricultural chemicals

Handle agricultural chemicals in strict accordance with the best practice developed for users by manufacturers and regulators. As well, when making up agricultural chemicals, just enough should be prepared so that little excess needs to be disposed of.

WATER TESTING

Good quality water for nursery production contains adequate but not excessive concentrations of inorganic ions and compounds in the correct ratios, while maintaining low levels of suspended solids and bacteria. Whether you are fertigating or relying on fertiliser placed in the mix the nutritional program needs to be designed in conjunction with water analysis data.

It is difficult to establish accurately how much each of the various substances in water contributes to the clogging of your irrigation equipment. However, it can be generally stated that clogging problems due to the occurrence of impurities in irrigation water become more acute if the water is high in the following:

- Suspended particles of organic or inorganic matter.
- Precipitate-forming elements, such as iron, manganese, calcium and magnesium.
- Bacteria that secrete slime which causes the suspension to accumulate or which acts chemically and causes the accumulation of sulphides and insoluble compounds of heavy metals.



Plant growth and nutrient uptake will depend on the chemical cocktail that is available in the container, some of which will be supplied by your irrigation water.

Water testing criteria can be categorised as follows:

- Biological
 - Bacteria
 - Algae
- Physical
 - Turbidity, light penetration
 - Colour
 - Suspended solids
- Chemical
 - pH
 - Electrical conductivity (salinity)
 - Nutrients (nitrogen, potassium and phosphorous)
 - Inorganic ions and compounds
 - Organic ions and compounds

The number of criteria that you have tested will be determined in part on the source of the water and the product you are growing. If you are recycling water or using liquid fertiliser then you will require more tests and more frequent monitoring to maintain the correct nutrient balance and unclogged irrigation equipment.

Other tests

Other tests that may be required include:

- Total suspended solids (TSS).
- Volatile suspended solids (VSS).
- Total dissolved solids (TDS).
- Turbidity. Important for nurseries contemplating using UV disinfection
- Hydrogen sulphide (H₂S). Water from deep bores (e.g. artesian basin) may require H₂S determination.

Irrigation water quality parameters

Other water quality parameters have been discussed in Table 6.

Monitoring water quality

An easy way to monitor your water quality is to regularly check some basic measurements such as salinity levels, pH, and nitrate concentrations. This can indicate if further testing by a laboratory is required. Ideally, these basic measurements should be taken and recorded regularly.

Nursery & Garden Industry Australia have developed an industry specific Environmental Management System (EMS) referred to EcoHort that provides businesses with a systematic approach to assess their environmental and natural resource management responsibilities, as part of their daily business management. The EcoHort program has stipulated that wastewater, release water and irrigation water should have the pH, EC and nitrate levels taken and recorded monthly. This program also recommends that irrigation water should be fully tested in a laboratory every 6 months.

Disinfestation best practice

In Australia water is usually disinfested by chlorination using either sodium hypochlorite or direct injection of gaseous chlorine. Some nurseries have chloro-bromination systems and several others use UV radiation. Whatever water disinfestation strategy you decide to use it is vital that you do a complete analysis of water quality over a 12 month period because various factors will influence how well disinfestation strategies will work.

There is not a lot of information on best practices as far as disinfestation is concerned but the following is the best available information on water disinfestation for the nursery industry. Much of this information has been generated by levy funded projects in Australia.

Chlorine (as hypochlorous acid)

Limited field and anecdotal data indicates that a 1 minute exposure to chlorine will control zoospores of *Phytophthora cinnamomi* and spores of *Alternaria alte* at 2 and 3 mg/L free chlorine respectively. However, there is little extensive quantitative data on other fungal plant pathogens. It is known that above pH 7, the amount of available hypochlorous acid in solution falls rapidly until little occurs at pH 8. Since the 1995 survey of nursery waste water showed that pH above 7 is typical for Australian nurseries (average 8 in Queensland), acidification is likely to be required in many nurseries.

Another disadvantage of chlorination is that its efficacy is reduced by organic matter, iron and nitrogenous compounds. Because of the occupational health and safety dangers of chlorine gas, this chemical will be phased out in the near the future.

Chlorine dioxide

Chlorine dioxide has been shown to be highly effective for disinfesting a range of plant pathogens including *Fusarium oxysporum*, *Alternaria zinniae*, *Colletotrichum capsici*, *Pythium ultimum* and *Phytophthora cinnamomi* (zoospores and chlamydospores) over a range of water pH levels.

It needs to be applied at an available concentration of 3 mg/L for 8 minutes to control waterborne fungal pathogens. Chlorine dioxide also oxidises iron.

In poorer quality water typical of that used after recycling, higher concentrations of chlorine dioxide to overcome demand by contaminants in the water will be needed. If you are applying chlorine dioxide using automated equipment it must have sensors placed in such a position in the irrigation system to account for chlorine dioxide drawdown by impurities in the water.

Disinfestation properties of chlorine dioxide are unaffected by pH as high as 10, so this method is widely applicable to the nursery and flower industries in Australia which, overall, have high water pH. Although chlorine dioxide equipment is more expensive than other chlorination systems, this method of disinfestation is likely to be more effective considering the quality of water in Australia.

The only factor stopping chlorine dioxide being recommended as best practice for water disinfestation is data lacking on its phytotoxicity and testing its efficacy on a wider range of organisms. A nursery in Victoria has successfully used chlorine dioxide without obvious phytotoxicity problems on a wide range of Proteaceae. Chlorite ions produced from chlorine dioxide may be hazardous to plant and animal health.

For more info

Water disinfestation – chloro-bromination and ozone systems get the thumbs up! *The Nursery Papers* 1997 No 008

For more info

Characterisation of water quality for ozonation processes. Part 1: Minimal set of analytical data (journal) Hoign, J. (1994), *Ozone Science and Engineering* 16:113 –120

Disinfectious effect of ozonation on water infested with several root-infecting pathogens (journal), Yamamota, H.; Terada, T.; Naganawa, T. and Tatsuyama, K. (1990), *Annals of the Phytopathological Society of Japan* 56:250–251

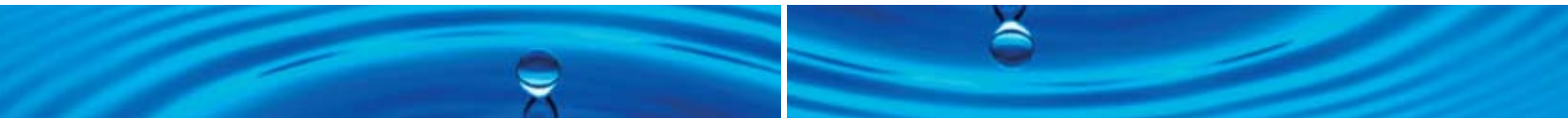

Bromination and chloro-bromination

Treatment of water by chloro-bromination is effective. The concentration (total chlorine and bromine) and exposure times required to control common plant pathogens in water are: *Phytophthora cinnamomi* chlamydospores at high pH, 8 mg/L for 8 minutes; *Fusarium oxysporum* 2 mg/L for 2 minutes; and *Pythium ultimum* at neutral pH, 2 mg/L for 8 minutes.

Ozonation

Ozone kills chlamydospores of *Phytophthora cinnamomi* in dam water at an average residual dose of 1.4 mg/L over 16 minutes. As the decay of ozone is logarithmic, a dose of 1.4 mg/L at 16 minutes indicates an initial dose between 2.5 and 3.5 mg/L. Oospores of *Pythium ultimum* in tap water are controlled with an average dose of 1.2–1.5 mg/L ozone and 4 minute contact time, and in dam water, an average residual dose of 0.5–0.7 mg/L for 8 minutes is required. *Fusarium oxysporum* conidia in dam water are killed after 4 minutes contact time with an average of 1.8 mg/L residual ozone. Ozone demand increases with alkalinity, and the concentration of bicarbonate, iron and ammonium.

Ultraviolet (UV) radiation

Ultraviolet radiation is an effective and environmentally friendly method of controlling *Phytophthora cinnamomi*, *Fusarium oxysporum*, *Colletotrichum capsici* and *Alternaria zinniae* if water has high UV transmission (greater than 50 % UV transmission after filtration) and exposure dose is at least $5.0 \times 10^5 \mu\text{W}\cdot\text{s}\cdot\text{cm}^{-2}$.

Alternaria zinniae has dark coloured spores and is the most difficult to kill with UV radiation and makes this method impractical. If you only want to kill *Phytophthora cinnamomi* and *Pythium ultimum*, radiation levels of only $4.3 \times 10^4 \mu\text{W}\cdot\text{s}\cdot\text{cm}^{-2}$ are required which is economically feasible if water quality is high.

For more info

Using ultra violet radiation and chlorine dioxide to control fungal plant pathogens with water, *The Nursery Papers* 1996 No 005

Equipment for irradiating water with UV must be designed so that pressure changes in pipes between the pump and the UV reactor are minimised, otherwise pathogens may be protected from the radiation. You also need to make sure that flow in the UV reactor is turbulent, otherwise organisms may be protected from radiation exposure. Water must also be filtered because solid particles may protect pathogens from radiation.

Ultra violet radiation can be recommended as best practice for nurseries which have recycled water with UV transmission greater than 50 % at a wavelength of 254 nm because of its environmentally friendly operation and low cost. Water with a UV transmission less than this can be disinfested with UV radiation, however, the dose needed increases greatly as UV transmission falls.

Heat

Although heat is used widely in Europe to kill plant pathogens in water it is likely to be very expensive in Australia. If the waste heat can be efficiently used for preheating, it might be considered in places where gas is cheap, such as in Victoria, however, the water must be treated at 95°C for at least 30 seconds for adequate disinfestation.

Microfiltration and slow sand filtration

Microfiltration and membrane filtration has been shown to be impractical in Europe because the poor quality water in nurseries there clogs filters. It also has extremely high operating costs.

For more info

A review of possibilities for disinfection of recirculation water from soilless cultures (journal) Runia, W.Th. (1995), *Acta Horticulturae* 382:221–229

Work on slow sand filtration (SSF) has demonstrated control of *Phytophthora* at flow rates below 300 L/hour/m² of surface area. *Fusarium oxysporum* was controlled but only at lower flow rates. This type of SSF may be used in conjunction with other non-chemical disinfection methods. Disinfectants in the sand filter will cause it to fail.

Biological broths which are antagonistic to plant pathogens such as *Botrytis* and algae can be grown and added to water supplies. These biological agents need proper scientific evaluation.

Table 8 – Making a disinfestation decision

Method	Advantages	Disadvantages	Cost	Degree of evaluation
Slow sand filtration	No chemicals	Maximum flow 300 L/hour/m ²	Cheap	Well tested
Chlorine dioxide	Works in poor quality water	Cost	Expensive,	Well tested will get cheaper
Chloro-bromine	Works in poor quality water	8 minute contact time	Cheap	Rejected in Europe
Membrane filter	No chemicals	Maintenance difficulties	Expensive	Rejected in Europe
Heat	No chemicals	Expensive unless cheap gas available	Expensive to run	Well tested in Europe
Ultra violet radiation	No chemicals	Only suitable for high quality water, and for <i>Pythium</i> and <i>Phytophthora spp.</i>	Cheap	Well tested
Hypochlorous acid (chlorination)	Simplicity	Does not work above pH 7	Cheap	Only tested on <i>Phytophthora spp.</i>
Ozone	Few residual chemicals	Cost, difficult to monitor	Expensive will get cheaper	Well tested

SUMMARY RECOMMENDATIONS FOR WATER RECYCLING BEST PRACTICE

- Nitrate-N levels in runoff water and dam water should be minimised and measured preferably on a monthly basis, and suitable adjustments made to fertiliser rates. Nitrate levels should not exceed 100 mg/L. Corresponding phosphate levels should not exceed 40 mg/L (15 mg/L for P-sensitive plants)
- Electrical conductivity of recycled water should be below 1 dS/m.
- Sodium levels should be below 100 mg/L (50 mg/L for roses).
- Sodium Adsorption Ratio for use on soil should be below 5.
- Chloride levels should be below 200 mg/L.
- pH should be in the range 5.0 to 7.0, depending on alkalinity level of water and disinfestation strategy.
- Calcium and magnesium levels should be balanced in a ratio of about two to one, with potassium 2 to 5 per cent of cations.

For more info

Slow flow sand filtration (SSF) for water treatment in nurseries and greenhouses, *The Nursery Papers* 1999 No 003

Disinfection of recirculating nutrient solutions by slow sand filtration (journal), Wohanka, W. (1995), *Acta Horticulturae* 382:246–251

A review of possibilities for disinfection of recirculation water from soilless cultures (journal), Runia, W. Th. (1995), *Acta Horticulturae* 382:221–229



For more info

Transmission of pelargonium flower break virus by recirculating nutrient solutions with and without slow sand filtration (journal),
Berkelman, B.; Wohanka, W. and Krczal, G.(1995), *Acta Horticulturae* 382:256–262

- Iron (ferrous) levels should be below 5 mg/L (in situations where iron blocks irrigation lines lower levels may be required).
 - Manganese levels should be below 0.2 mg/L.
 - Copper levels should be below 0.2 mg/L. Copper based fungicides and algicides should be used sparingly if at all.
 - Zinc levels should be below 2 mg/L.
 - Boron levels should be below 0.3 mg/L.
 - Aluminium levels should be below 5 mg/L.
 - Molybdenum levels should be below 0.01 mg/L.
-
- Fluoride levels should be kept below 1 mg/L.
 - Herbicides should be kept below 0.1 mg/L. Persistent herbicides such as atrazine and simazine should not be used. Apply pot herbicides Rout and Ronstar® judiciously with minimum wastage on ground between pots.
 - Disinfection chemicals such as hypochlorous acid should be monitored. Hypochlorous acid (available free chlorine) levels in irrigation water should not exceed 4 mg/L.
 - UV transmittance of water at 254 nm should be regularly monitored if UV radiation is used for disinfection.
 - Chlorine dioxide be considered for disinfection if available residual level irrigated onto crops can be kept below 2 mg/L.
 - Solids, sediment, pinebark and perlite flotsam need to be removed before recycling.
 - Only make up enough of any agricultural chemical for task required so that there is no excess to be disposed of.
 - Operators should complete the National Farm Chemical Users Course or equivalent.

FURTHER READING

Characterisation of water quality for ozonation processes. Part 1: Minimal set of analytical data (journal), Hoigne, J. (1994), *Ozone Science and Engineering* 16:113–120

A compilation of Australian water quality criteria (paper), Hart, B.T. (1974), Australian Water Resources Council Technical Paper No.7, Australian Government Publishing Services, Canberra

Constructed wetlands in the Hawkesbury-Nepean (information sheet) (1995), Hawkesbury Nepean Catchment Management Trust

Constructed wetland manual (book) (1997), NSW Department of Land and Water Conservation

Disinfection of recirculating nutrient solutions by slow sand filtration (journal), Wohanka, W. (1995), *Acta Horticulturae* 382:246–251

Disinfectious effect of ozonation on water infested with several root-infecting pathogens (journal), Yamamoto, H.; Terada, T.; Nagawana, T. and Tatsuyama, K. (1990), *Annals of the Phytopathological Society of Japan* 56:250–251

Disinfestation of plant pathogens in recycled water using UV radiation and chlorine dioxide (report), Mebalds, M.; Hepworth G.; van der Linden, A. and Beardsell, D. (1995), Technical report to HRDC

Draft irrigation and fertilization Best Management Practices for producing container-grown woody environmental plants (booklet), Yeager, T.; Fare, D.; Gilliam, C. and Niemiera, A. (1994), University of Florida

The fourth international symposium of soil and substrate infestation and disinfestation (journal), Vancher, A. (1995), *Acta Horticulturae* 382

Growing media for ornamental plants and turf 4th Edition (book), Handreck, K. and Black, N. (2010), University of NSW Press

Managing water in plant nurseries Edition 2, Rolfe, C.; Yiasoumi, W. and Keskula, E. (2003), NSW Agriculture

Nutrition in horticulture (proceedings), Hunter, M.N. and Eldershaw, V.J. (1993), Proceedings of a review workshop, Gatton 4–6 May 1993

Put your water through analysis (journal), Biernbaum, J.A. (1993), *Greenhouse Grower*, Nov 1993:32–36

A review of possibilities for disinfection of recirculation water from soilless cultures (journal) Runia, W.Th. (1995), *Acta Horticulturae* 382:221–229

The Nursery Papers, Nursery & Garden Industry Australia

Transmission of pelargonium flower break virus by recirculating nutrient solutions with and without slow sand filtration (journal), Berkelman, B.; Wohanka, W. and Krczal, G. (1995), *Acta Horticulturae* 382:256–262

Waste water re-use from the standpoint of irrigated agriculture (journal), Aikman, D.I. (1983), *Public Health Engineer* 11:35–41

Water quality for agriculture, irrigation and drainage Paper No. 29 (paper), Ayres, R.S. and Westcot, D.W. (1976), FAO, Rome

Water quality survey of the Australian nursery and flower industries (report), Beardsell, D. and James, L. (1995), Technical Report for HRDC Project No. NY 320

Water sources: the detection and pathogenicity of *Phytophthora* spp. in water (report), Smith, P.M.; Ousley M.A. and Middleton J. (1985), Glasshouse Crops Research Institute Report 1984, 102–105

Water treatment handbook (book), Berne, F. and Richard, Y. (eds) (1991) Vols. 1 & 2., 6th Edition, Degremont Lavoisier, Paris



4 EFFECTIVE MANAGEMENT OF SEDIMENT, LITTER AND DRAINAGE

Nursery developments change the natural land surfaces and drainage patterns of irrigation and storm waters by increasing and concentrating runoff volumes. This can produce high velocity flows which cause erosion resulting in sedimentation and litter movement. Sedimentation produces muddy streams and silts up dams and watercourses with nutrient rich material. Litter, in particular polystyrene, plastics, growing media and mulches, can clog pumps and drainage lines. It is also aesthetically displeasing and environmentally unacceptable. To minimise the effect of nursery development and runoff water on the environment, an erosion, sediment and litter control plan should be prepared for each site for both for when the nursery is being developed and for general day-to-day operation of the nursery. Each plan needs to be site specific and take into consideration topographic limitations, climate patterns, soil types, drainage system, product being grown, and business management practices. This chapter details some of the options and practices that you, as a nursery operator, can consider when preparing control plans to manage sediment and litter for both the development and operation phases of the nursery. It also outlines some of the drainage design considerations that will help reduce erosion and litter transfer.

What causes sedimentation?

Many nurseries have shallow water tables caused by frequent irrigation, hard areas like roads and carparks, buildings, glasshouses and igloos, and areas covered by plastic and matting. This produces high volumes of runoff water when it rains. The increased volume and concentration of runoff will increase the velocity of the flows and unless the drainage system has been designed to cope, excessive erosion is likely to occur. Some soils are more prone to erosion than others, and the soil type and slopes should be carefully looked at when designing your drainage system.

SITE ASSESSMENT FOR DRAINAGE SYSTEMS

Nurseries are located in all sorts of places and not all of them are easy to develop for drainage systems. It is therefore important to collect all the useful and relevant information about the site and location to fully assess the drainage system.

Topography

Most drainage systems rely on gravity to move water from the highest points to the lowest parts of the nursery. The slope available will dictate the size and type of drains employed. For most sites the cost of a complete topographical survey of the nursery that picks up all features, providing the basis for the location of drains, crossings, inspection pits, sumps and storage areas, will be well repaid in the quality of drainage system design, not to mention an accurate plan of all the nursery features including underground services.

Rainfall intensities

The volume of stormwater you are likely to deal with can be calculated from the rainfall intensities and frequency of storm events in your area. This can be calculated by using the *Australian Rainfall and Runoff* program that is detailed in Waterworks Module 3 notes that also provide a calculator to provide this information for most nursery locations within Australia.

The volumes of water the drainage system needs to deal with can be determined by knowing the size of various areas from the topographical survey.

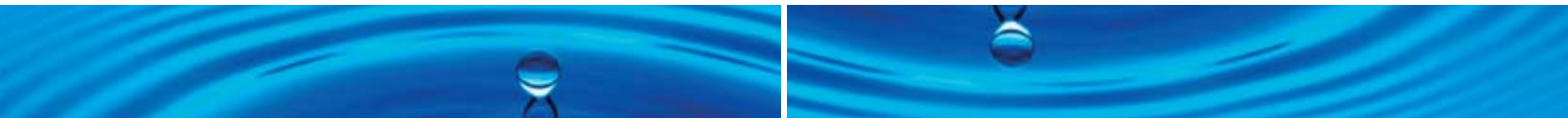

Water table

If the water table under the nursery is high then a subsurface drainage system may be required to lower this level so that surface slumping is prevented from vehicle movement around the nursery.

Runoff quality

All water that runs off a nursery is not the same quality. This can be illustrated by examining the water source, such as:

- Roof runoff from potting and machinery sheds and glasshouses is a source of excellent quality water, which should be highly valued.
- Traffic areas such as roadways, carparks access lanes may have mud and vehicle contaminants but can usually be disposed of as ordinary storm water.
- Runoff from production areas is likely to contain dissolved and solid material that might not conform to the local environmental requirements. This may require some treatment before disposal or reuse.

The ideal situation is to design your drainage system to allow for a separation of water according to quality. That way you will not need to have in place systems that can handle large amounts of contaminated water, when only a small percentage of your drainage falls into this category. However, the size and layout of the nursery set-up will determine the ability and financial viability of separation.

Regulations

Before you design and/or upgrade the drainage system there are a number of regulations that you will need to consider. These will include:

- Environmental legislation
- Water management acts
- Local catchment management plans
- Local government regulations
- Common law

DRAINAGE SYSTEMS

A well designed, installed and maintained drainage system will minimise erosion and control sediment and litter movement. Most systems can deal with daily irrigation runoff and moderate storm runoff. Heavy storm runoff may cause some erosion and flooding. Sediment and litter traps can be installed to provide for such events. Drains are classified according to their physical location as being either subsurface or surface drains. Most nurseries use a combination. The type of drainage system you use will be determined by considerations such as:

- runoff volumes
- slope
- required drain capacity
- soil type
- location of the drain
- maintenance requirements.

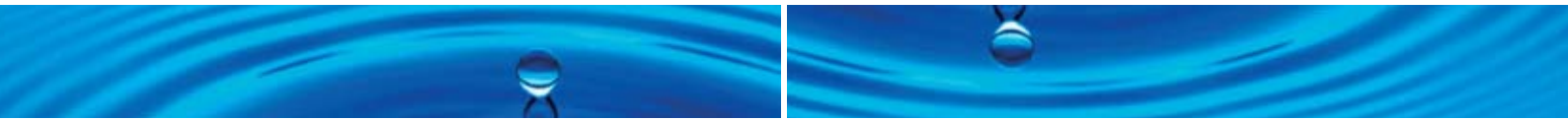

Surface drains

These should be designed and constructed so that they do not erode in heavy rain and can be easily maintained to allow their designed capacity to pass water at all times. Grassed waterways or concrete drains are most commonly used. Grassed waterways are only suitable for collecting and transporting stormwater. They are not to be used for transporting irrigation runoff because the regularity of irrigation means the drains would not dry out and they would become soggy and choked with weeds, reducing their capacity.

Masonry drains, gutters and gravel drains can be incorporated where the area is too restricted or too steep. These conduits can handle higher velocities than grass and can handle irrigation and stormwater runoff.

Unsealed drains cause erosion and contaminate drainage water with soil particles. Sealed drains are easier to maintain and the water is easier to treat before disposal or reuse.

Shallow dish drains can be sealed with plastic or weedmat then topped with coarse stone to dissipate energy and slow velocity to prevent erosion.

Subsurface drains

These can be used to carry high quality water from roofs and production areas. PVC stormwater piping is usually suitable for most installations. The most common pipes in nursery drainage are slotted subsoil drainage pipe (known as Ag pipe) wrapped or packed in sand or gravel, PVC stormwater pipe and concrete pipes.

Generally a pipe grade of less than 1 in 100 will not provide sufficient velocity to self clean pipes that are likely to carry debris from production areas. It is recommended that this be the flattest grade used.

By dividing up the nursery into sections you can size piping to suit the rainfall intensities for each area. These discharge rates can then be combined as pipes join to continue sizing for the whole system.

Where pipes change directions or join with other pipes, junction boxes should be installed. These can be constructed on-site or purchased as pre-cast boxes of different dimensions made from concrete and fibre cement or prefabricated polyethylene. They come with grates or metal and concrete lids to suit.

When moving from subsurface drains to surface drains a suitable transition needs to be constructed to reduce the high velocity coming from the pipe to a non-erosive velocity to suit the open drain. Concrete structures or large rock rip-rap are usually considered here.

See Table 9 for more information.

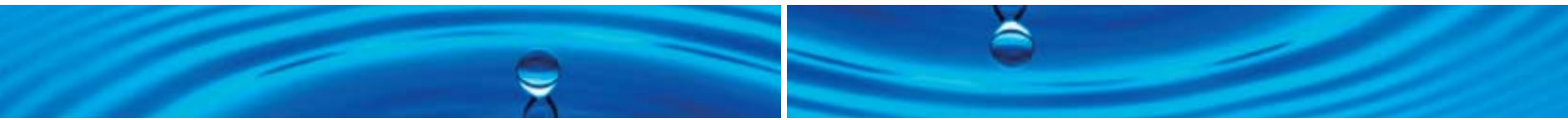

Table 9 – Some considerations when selecting a drainage system

Surface drains	Subsurface drains
Lower installation costs	Higher installation costs
Loss of land use for other purposes	No loss of land use for other purposes
Regular maintenance required	Maintenance is usually minimal
Remedial work readily undertaken	Remedial work can involve significant costs and time
Only collects surface runoff	Capable of collecting both surface runoff and groundwater
Major structures such as culverts, bridges, fences may be required	No major structures required
Potential hazard to pedestrian and vehicular movement	Not a potential hazard to pedestrian and vehicular movement
May be aesthetically poor	Not visible, hence no aesthetic effect
Drains are visible and potential problems can be acted upon before major difficulties arise	Drains are not visible and potential problems cannot be acted upon until the difficulties manifest themselves
Drain capacity is limited only by the area available for the installation	If a pipe system, drain capacity is limited by the pipe cross section
Litter traps can be incorporated in the drain itself	Collect litter before water enters drain
Can be readily expanded/extended	Can be difficult to expand

Drainage system capacity

The capacity or volume of drainage water to be handled by the drainage system is mainly a function of rainfall intensity, surface type and drainage area. Calculating drainage volume is not complicated but it does require a knowledge of hydrology and an understanding of acceptable degrees of risk.

Many local authorities will dictate the degree of risk relevant to your situation. For example, you may be asked to design your drainage system so it can cater for a 1 in 20 year storm event. In other words, the risk (in terms of inconvenience and damage caused by a storm event greater than 1 in 20 years) is acceptable in relation to the cost of providing that capacity drainage system.

If your local authority does not have any guidelines for design storm events, a suggestion is to adopt, as a minimum, a 1 in 20 year storm event for permanent drainage structures.



CONSIDERATIONS WHEN DEVELOPING SEDIMENT AND LITTER CONTROL PLANS

When you are building a new nursery or expanding an existing nursery, the risk of the disturbed soil eroding is high. A plan to control the movement of sediment needs to be prepared before work starts so that you stop erosion from occurring. Things you can consider including in this plan are detailed in the following section. Further information can be found in Appendix 3.

Construction phase control plan

Prevention is the best way of avoiding the impacts of sedimentation and litter generation. If you are developing a construction phase control plan consider the following to minimise the impact of erosion, sedimentation and litter generation.

Site selection

A good place to begin is to identify natural features such as drainage lines, water bodies and existing vegetation that can be retained in the development. Try to:

- avoid hazard areas like steep slopes, unstable slopes and drainage lines
- integrate runoff management with erosion, sediment and litter control.

Making the development fit the terrain will minimise the risk of erosion and sedimentation. For example, aligning access roads and laying out igloos and production areas to minimise the amount of land that needs to be disturbed can also minimise the risk of erosion.

Expose the smallest possible area of land for the shortest possible time

Try to stage development so that land disturbance is confined to areas of manageable size. This will also limit the time disturbed areas are exposed to erosion.

At the same time, try to retain as much of the natural vegetation as possible. This is the most effective form of erosion control as vegetation both absorbs and uses water. As well, revegetating areas once they are disturbed is costly and time consuming.

Seasonal variations in rainfall result in periods of varying erosion risk during the year. Where possible, try to schedule land disturbance operations during the time of year when erosion is least likely to be a problem.

Save topsoil for reuse

With any land development it is essential that stripped topsoil be stockpiled. Put these topsoil stockpiles outside drainage lines and protect them with temporary control measures to stop them becoming a source of sediment. Respread the topsoil on areas to be revegetated.

Control site runoff

Permanent drainage works must be installed early in the development to protect disturbed areas from runoff and to carry stormwater safely through the site. All runoff must be carried away slowly enough so it doesn't cause erosion.

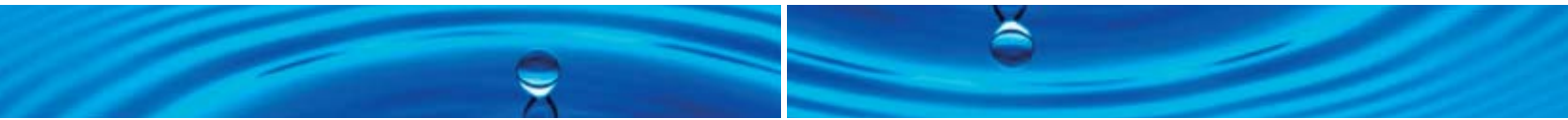

Select sealing materials carefully

The road and path sealing material you use can affect the amount of sediment generated. On one hand, a properly constructed bitumen or concrete sealed road or path will generate no sediment. On the other hand, a path or road sealed with a road base material such as crushed shale will erode over time and generate a clay sediment. Similarly, crushed sandstone will generate sand sediments, and recycled concrete or crushed demolition material will also erode and generate sediments.

To help minimise sediment generation it is a good idea to install adequate drainage controls and make sure that the road base material is well compacted.

Maintain stockpiled material

Stockpiles of excavated earth are a potential source of sediment and litter. To minimise sediment and litter generation from stockpiled material consider the following:

- when excavating, keep stockpiled topsoil separate from underburden
- apply a sediment control fence
- mulch, roughen and seed excavated stockpiles with sterile grasses if you are keeping them for more than 28 days
- enclose all unstabilised excavated stockpiles with silt fences or a drainage system that will collect contaminated runoff.

Operation control plan

Once you have built the nursery, or completed the extensions, and it is producing, you need to develop a plan to deal with the day-to-day risks of erosion and generation of sediments and litter. The EcoHort program can further assist you in developing a plan for your business.

Consider the following general principles:

Prepare an erosion sediment and litter control plan

It is advisable to consider a strategy to manage erosion, sedimentation and litter early in any development. If you operate an existing nursery it is a good idea to assess the situation and quickly implement a plan.

Many local authorities can help you to prepare your plan. In your plan erosion control must be recognised as being of primary importance. This can be done by managing runoff so that the speed at which it flows does not cause erosion, by minimising the length of slope exposed during land shaping, and by protecting the soil surface.

Sediment and litter control involves trapping and containing material that has already been eroded. Erosion control is more effective than and preferable to sediment control and will often be the only alternative for fine grained and dispersible soils.

Control site runoff

Try to maintain natural drainage lines and control runoff entering from neighbouring properties. As well, it is advisable to divert clean runoff from within your property around developed areas to alternative stable outlets or to storage dams for later use for irrigation. All runoff should flow at a speed that doesn't cause erosion.

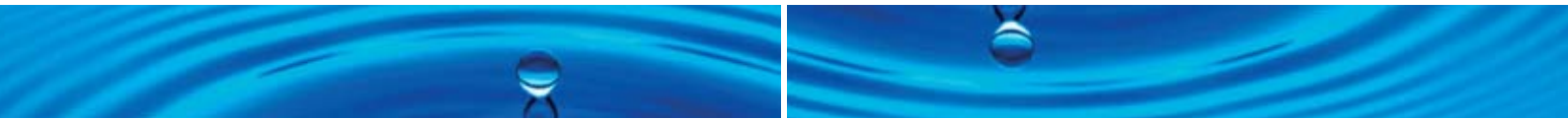

For more info

Urban erosion and sediment control field guide (booklet) (1995), NSW Department of Conservation and Land Management, Sydney

Environmental guidelines for major construction sites (booklet) (1996), Environmental Protection Authority, Victoria, Melbourne

Use erosion control measures

Use erosion control measures during all stages of development and ongoing nursery operation to minimise sediment generation. Controlling erosion close to its source can reduce the demand on sediment trapping structures.

Use sediment control measures

Filter runoff through sediment trapping structures to minimise or stop sediment leaving the site or entering your water storage. These measures work by reducing the velocity of runoff and letting sediment settle by gravity or filtration. Eroded sediment must be trapped before it leaves the site and affects adjacent property and downstream watercourses.

Implement litter reduction strategies

Potential litter sources while you are building or extending the nursery include building material washed away during a storm and rubbish thrown away by construction workers. Other sources include rubbish thrown away by employees, and plastic pots, labels, growing media, mulch and polystyrene washed or blown from their storage area. Litter is often caused by thoughtlessness and the absence of suitable litter bins on the site. So that litter is not generated and is disposed of responsibly it is suggested that:

- you and your staff practise a high standard of housekeeping
- bins be provided for staff at convenient locations, e.g. where they eat lunch
- materials are not left where they can be washed away to become litter i.e. provide suitably enclosed storage areas for stockpiled materials like growing media and designated storage areas for polystyrene boxes, plastic pots, cardboard and product name tags
- you make staff aware of the need to avoid littering.

Use litter control measure

Pass runoff through litter trapping devices to minimise or stop litter leaving the site, entering your water storage or blocking drains. These devices work by physically trapping the litter but allowing water to pass through them.

Rehabilitate disturbed areas

Vegetation is the most effective way of controlling erosion and sedimentation. When areas are disturbed or made bare it is essential to stabilise them and establish a grass cover as soon as possible. Similarly, all roads, parking areas, delivery bays, etc must be stabilised or maintained with appropriate subgrade material.

Implement an Irrigation management strategy

Overwatering plants will result in unnecessary runoff. Runoff from irrigation can cause erosion and carry litter. Poorly maintained irrigation pipes and fittings (including sprinklers) can leak and add to the unnecessary runoff load. It is important to implement an irrigation strategy (or redesign existing irrigation systems, or do both) to avoid overwatering.

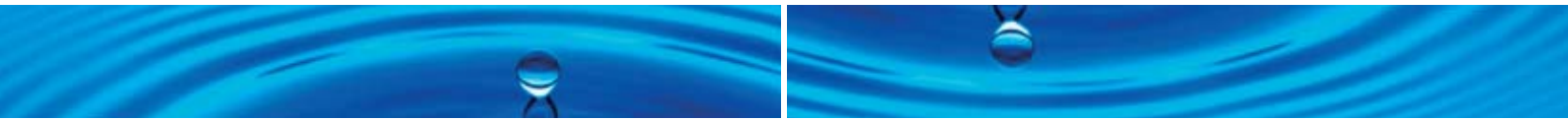

Maintain stockpiled material

Stockpiles of growing media and other materials are a potential source of sediment and litter. To minimise sediment and litter generated from stockpiled material consider the following:

- locate stockpiles away from drainage
- provide a cover over the stockpile
- minimise the number and size of stockpiles
- build the stockpile with no slope greater than 2:1 (horizontal to vertical)
- provide suitably enclosed storage areas for stockpiled material such as growing media or enclose the growing media stockpile with silt fences or a drainage system that will collect contaminated runoff, or do both
- avoid locating stockpiles close to waterways.

Maintain erosion and sediment control measures

Regularly inspect and maintain all erosion and sediment control measures to ensure they function efficiently. A suggested maintenance schedule is outlined in Table 10.

Inspections, particularly during storms, will show whether devices are operating effectively. Where a device proves inadequate, it should be quickly redesigned to make it effective.

Table 10 – Suggested maintenance schedule for erosion and sediment control measures

Installation	Possible problems	Inspection frequency	Remedial action
Drainage (drains and banks)	Water diversion not achieved	Weekly	Repair damaged drains and/or relocate drains
	Weed growth, sediment	Monthly	Remove weeds, litter and sediment
Sediment devices (hay bales, filter fences, sediment traps)	Ineffective sediment control	Weekly, or within first 2 hours of a storm	Remove sediment/litter from device and ensure control is properly built. Replace damaged geotextile of hay bales
Check dams	Movement or damage to dam	Monthly	Repair/replace damaged structure
Roads	Soil on paved roads	Weekly	Maintain rumble grids
	Rilling of unsealed roads	Weekly	Suitably pave roads and ensure drainage controls around area
Vegetated buffers	Vegetation loss	Weekly	Revegetate and keep traffic off vegetated areas and install drainage controls around the area
Level spreaders	Erosion rills and damage to vegetative cover	Monthly	Repair damaged areas and ensure outlet size is adequate
Stockpiles and bare slopes	Erosion and sedimentation	Weekly	Minimise exposure to run-off and install effective stabilisation measures
Sedimentation basins	Sediments not effectively removed	Weekly	Modify basin design to increase retention time and/or add flocculants
	Erosion rills and loss of vegetative cover	Monthly	Repair damaged area and/or revegetate
Unvegetated areas	Erosion rills and sedimentation	Weekly	Place mulch or geofabric and ensure adequate drainage around area
Litter control devices	Litter on and off site	Daily	Clean up litter originating on site. Review number/position of rubbish bins. Speak to staff about litter disposal and ensure materials are not stored in a way that results in generating litter

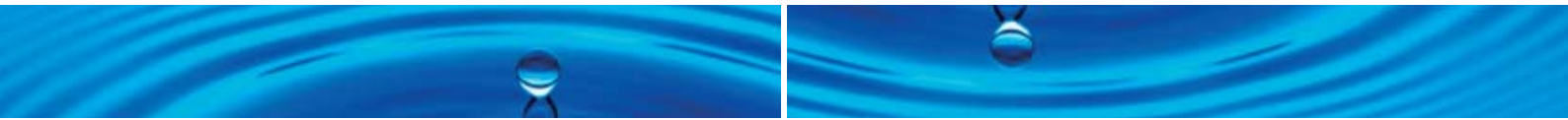

Summary

For both existing and proposed nurseries, consider the following measures to minimise erosion, sediment and litter generation:

- try to retain natural drainage lines and, if suitable, existing vegetation
- prepare a strategy to control erosion and sedimentation
- keep land clearance to a minimum
- avoid clearing areas of highly erodible soils and steep slopes
- revegetate and mulch construction work as it is completed
- keep the time between clearing and revegetation to an absolute minimum
- coordinate work schedules so that there are no delays in construction activities as this could result in disturbed land remaining unstabilised
- program construction activities so soil is exposed, as much as possible, when the risk of erosion is low
- maintain stockpiled material effectively
- stockpile topsoil for reuse during construction. Vegetate and stabilise where appropriate.
- install drainage works as soon as possible
- stabilise the site and install and maintain erosion control devices
- implement litter reduction strategies
- install and maintain sediment and litter control devices
- keep vehicles to well defined roadways
- keep roadways off steep slopes wherever possible
- design the slope of earth excavations to minimise the angle of incline
- rip bare surfaces to increase water infiltration (this will both decrease the amount and velocity of runoff water)
- implement an irrigation management strategy that includes maintenance
- use sealing materials that won't erode.

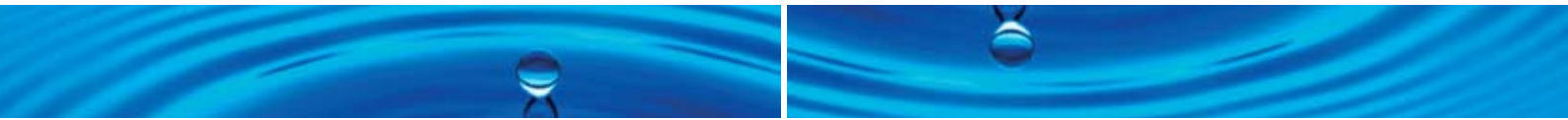

SEDIMENT CONTROL STRUCTURES AND DEVICES

There are many techniques and devices for controlling erosion and collecting sediment and litter. Some of these are described briefly in this section and accompanied by illustrations to help you assess whether they are applicable to your nursery. Control measures can take several forms, including:

- reduction and control of discharges and runoff
- source reduction
- water velocity control
- erosion control devices
- sediment control devices
- litter control devices.

Reducing and controlling discharges and runoff

Accounting for the physical limitations of development imposed by landform, soil types and drainage characteristics can help reduce and control discharges and runoff. Stabilisation and revegetation work should be done as soon as possible after any earthworks are finished, and groundcover vegetation should be retained wherever possible. In this way, the volume of runoff is reduced by increasing the amount of pervious area.

Try to divert clean runoff away from areas that have been cleared or are not adequately sealed. This stops clean runoff from becoming contaminated with sediment or litter. To do this build diversion banks and intercept drains around the site while ensuring that the water discharging from the banks or drains is disposed of without causing erosion.

Runoff should enter a storage dam or leave the property through a sedimentation control installation. By doing this silt laden runoff cannot escape the site and pollute surface waters, rather it can be treated on site.

Source reduction

Sediment from surface runoff can be reduced using infiltration devices, on-site detention and overland flow modification.

Infiltration devices

These include dutch drains (rubble trenches or french drains), lawn coring, recharge basins, seepage pits, and porous pavements.

On-site detention

This includes using areas above ground such as carparks or purpose built underground tanks to temporarily store stormwater runoff. On-site detention helps control flooding and reduce erosion and sedimentation. It also allows smaller diameter pipes to be used in the drainage system and reduces flow rates to levels which are manageable in downstream drainage systems.

Overland flow modification

An alternative to conventional kerb and gutter and other impervious drains. Grassed swales (shallow, broad surface drains) are typical of this type of device. They reduce peak runoff volumes by increasing the amount of pervious area.

Water velocity control

There is a direct relationship between how fast water flows over exposed soil and the rate of erosion. The higher the flow velocity, the greater the potential for erosion. An effective way of minimising flow velocities is to minimise the length of continuous slopes where flowing water can scour.

Installing rock or masonry structures to slow water flows is an effective measure to reduce erosion in areas where high water flows are expected.

To stop scouring, drainage lines need to be lined or velocity reducing structures, such as crushed rock or geotextile, installed.

Erosion control devices

These devices include:

- catch drains and banks
- diversion drains and banks
- energy dissipators
- level spreaders.

Catch drains and banks

Both catch drains and banks run across the slope and must be built at a non erosive grade.

They are physically smaller than diversion drains and banks. For example, the depth of a catch drain is typically from 200 to 300 mm while a diversion drain can be over a metre deep. Otherwise, there is no difference between catch drains and diversion drains or catch banks and diversion banks.

These drains are best stabilised by grass. However, depending on location and design practices, stone pitching, geotextile or masonry lining may be more suitable, particularly in steep terrain or areas with highly dispersive soils. Drains and banks are used together or individually to intercept and direct runoff to a desired location. For example they may be used to:

- intercept and direct sediment laden runoff to a sediment control device
- intercept and direct clean runoff to a storage dam
- reduce the flow path length of slope, thus reducing the velocity of flow and the potential erosion/ sediment hazard.

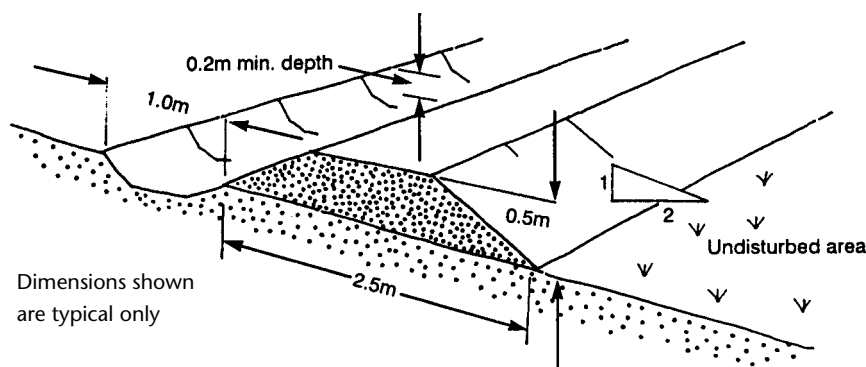

Fig. 11 – Bank with drain

Energy dissipators

An energy dissipator, for example a rock check dam, is built across a channel or flow path to reduce the velocity of flow. Energy dissipators can be temporary structures, like the one illustrated in Figure 12, or they may be permanent masonry structures. By reducing the flow velocity energy dissipators alleviate potential channel erosion and, depending on their design, can also act as sediment traps.

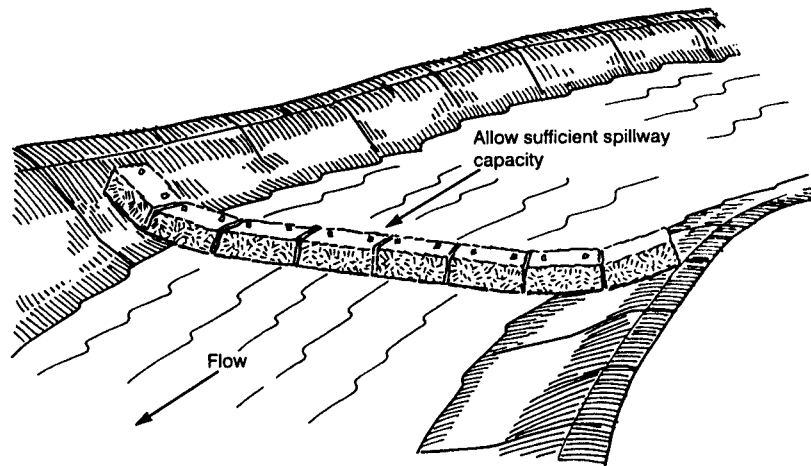

Fig. 12 – A check dam – an example of an energy dissipator

Level spreaders

Level spreaders (or sills), are shallow, level excavations at the outlet of an earth channel or bank. The level section (sill) dissipates the flow from the channel or bank by spreading it over a wider area. In a way they act like a spillway on an earth dam. By spreading the flow the erosive effect of the water flow is reduced below the outlet.

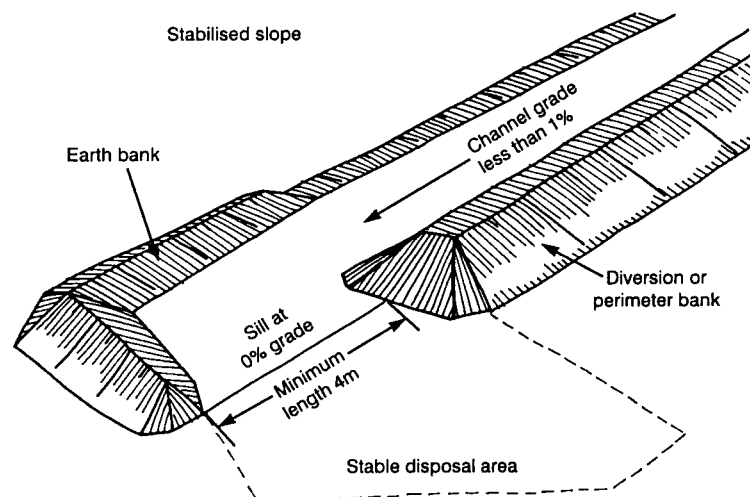

Fig. 13 – A level spreader or sill

Sediment control devices

These devices stop coarse sediments getting into dams and waterways. Sediment control devices include:

- hay bales
- filter fences
- sediment traps
- sedimentation basins.

Permanent groundcover is an effective way of minimising sediment runoff so it is advisable to try to retain existing vegetation and revegetate bare areas.

Hay bales

Hay bales are temporary structures placed around the perimeter of an area and held in place with stakes (typically star pickets). They are used to stop sediment moving from the area they enclose or to stop sediment entering an area they line.

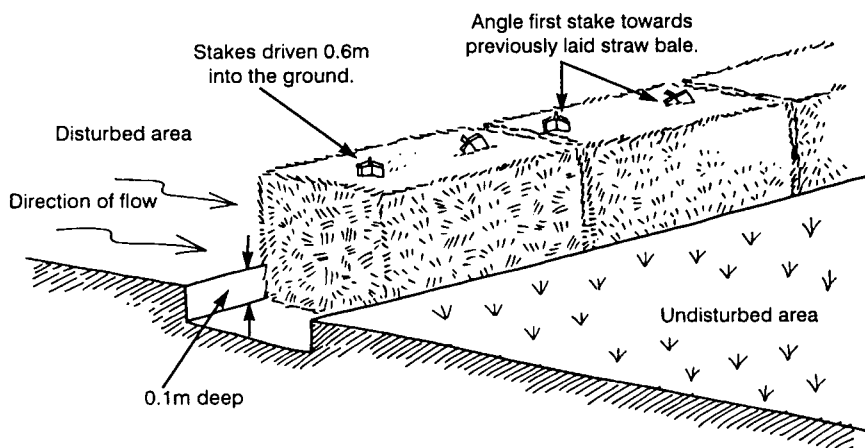

Fig. 14 – Straw bale sediment filter

Filter fences

Filter fences (also called sediment fences) are temporary barriers of geotextile material, usually supported by steel posts or, occasionally, steel mesh. These structures filter runoff, trapping the sediment and allowing filtered water to pass through. They could be particularly useful around large stockpiles of growing media and similar materials.

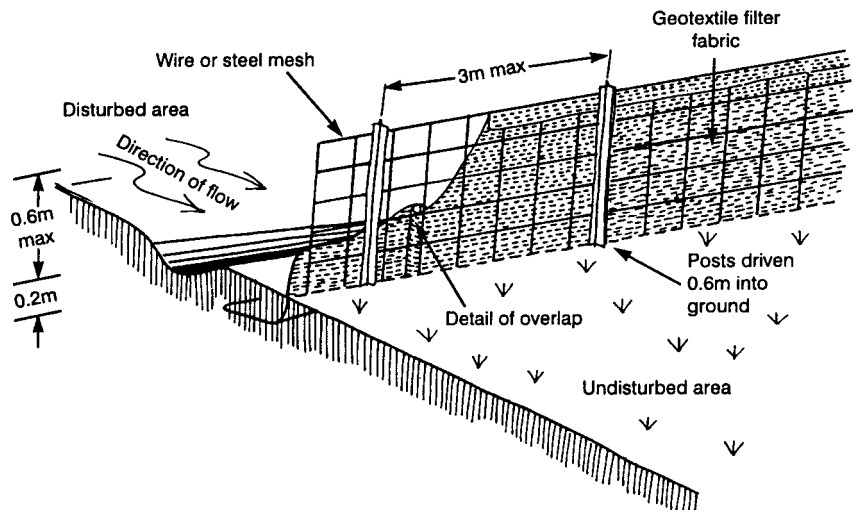

Fig. 15 – Typical sediment fence

Sediment traps

Sediment traps use an excavation or an embankment or both with an overflow raised above the bottom of the excavation. They are used at runoff outlets where flow is concentrated. The traps slow the water velocity and allow the sediment to drop out of suspension. These devices must be cleaned regularly.

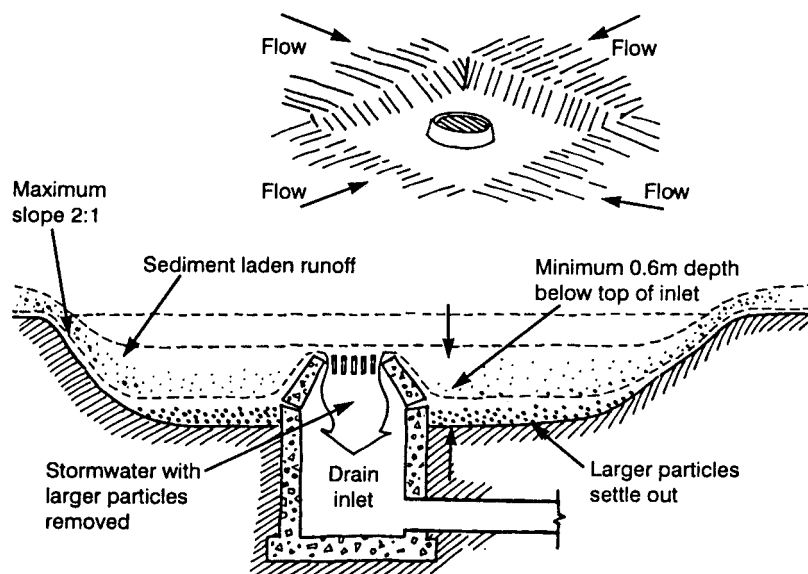

Fig. 16 – Sediment trap

Sedimentation basins

Sedimentation basins are dams (or large excavations) which intercept sediment laden runoff and retain the sediment.

They are designed to trap sediment that has escaped other sediment control devices like filter fences located further upstream in the drainage catchment. They hold the sediment contaminated runoff long enough for the suspended material to settle out.

Litter control devices

These devices stop litter from getting into dams and waterways. Both sediment and litter control devices are designed to stop drainage lines getting blocked as this can increase the risk and frequency of flooding. Installing these devices upstream of flow retardation basins and wetlands also brings other benefits, including: reducing maintenance of the controls, prolonging their life, and reducing the amount of litter that accumulates in them. Litter control devices include:

- trash racks
- trash baskets
- baffled traps.

Trash racks

Trash racks are normally made of metal bars but timber slats can be used. The bars or slats are spaced at intervals slightly smaller than the expected width of the floating debris. They are placed where flow is concentrated to trap debris but allow water flow through them.

Trash baskets

Trash baskets are made of metal mesh and are placed in excavations, similar to the sediment trap arrangement previously illustrated, which are readily accessible to allow easy removal of the basket for cleaning. They are placed where flow is concentrated to trap debris but allow water flow through the bottom of the basket.

Baffled traps

Baffled traps contain a series of parallel slats (in timber or metal) spaced at right angles to the flow direction. The baffles are normally alternated with high and low positions. A baffle trap will allow water flow between the baffles but traps floating debris within the baffle spacing.

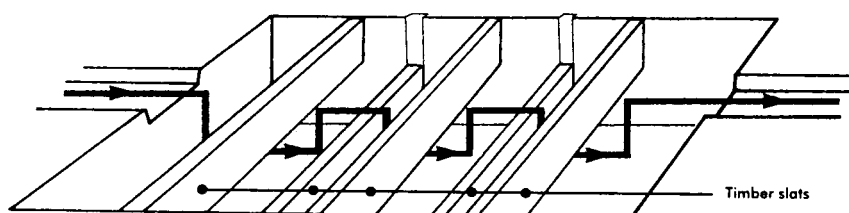

Fig. 17 – Typical baffle trap



Legislative responsibilities

Comprehensive environmental legislation gives considerable power to many public authorities to regulate the consequences of development, including the impact of runoff. These powers range from environmental planning instruments through to more detailed development control plans.

Check with your local authority to ascertain the requirements you may have to meet.

Acknowledgments

Elie Elia, Environment Protection Authority, Victoria Neil Rendell, NSW Department of Land and Water Conservation Department of Land and Water which was the source for Figures 11 to 16 in this chapter.

FURTHER READING

Australian rainfall and runoff (booklet), Pilgrim, D.H. (Ed) (1987), Institute of Engineers, Australia

Design manual for urban erosion and sediment control (book), Scott & Furphy Pty Ltd (1988), National Capital Development Commission, Canberra

Environmental guidelines for major construction sites, (booklet), (1996), Environment Protection Authority (Victoria), Melbourne

Erosion and sediment control handbook (book), Goldman, S.I.; Jackson, K. and Bursztynsky, T.A. (1986), McGraw-Hill Book Company

Erosion and sediment control – model policy and code of practice (booklet), (1993), NSW Department of Land and Water Conservation, Sydney

Guidelines for erosion and sediment control on building sites, ACT (booklet), (1989), Pollution Control Authority, Canberra

Managing water in plant nurseries (book), Rolfe, C.; Yiasoumi W. and Keskula, E, (Eds) (2002), NSW Agriculture, Orange

Principles of water quality control (book), Tebbut, T.H.Y. (1990), Pergammon Press, 4th edition

Soil erosion and sediment control engineering guidelines for Queensland construction sites (booklet), Institute of Engineers, Australia, 1996

Soil and water management for urban development, NSW (booklet), (1993), NSW Department of Housing, Sydney

Soil sense, soil management for NSW north coast farmers (book), Lines-Kelly, R. (1995), NSW Agriculture, Wollongbar Agricultural Institute

Urban erosion and sediment control (booklet), Hunt, J.S. (Ed) (1992), NSW Department of Conservation and Land Management, Sydney

Urban erosion and sediment control – field guide (booklet), (1995), NSW Department of Conservation and Land Management, Sydney

What do all the numbers mean? (pamphlet), Hazelton, P.A. and Murphy, B.W. (1992), NSW Department of Land and Water Conservation, Sydney



5 MAXIMISING THE RETENTION OF NUTRIENTS TO IMPROVE THE EFFICIENCY OF PRODUCTION AND MAINTAIN WATER QUALITY

Most nursery waste water is the product of the water that drains from pots (leachate) after rain or irrigation, and the water that falls on the ground between pots and onto other non producing areas of the nursery such as pathways, roads and buildings.

While leachate is the lesser in quantity of the two, it contributes most of the nutrient present in nursery waste water. This means that the key to minimising nutrient losses in waste water is reducing leachate which is achieved by adopting practices that result in water and fertilisers being used more efficiently.

However, this is not to ignore the need to minimise the amount of water falling on non productive ground, a subject covered in detail in Chapter 1.

MANAGEMENT STRATEGIES

There are five main strategies for reducing nutrient loss in nursery waste water. They are as follows:

- improve the delivery of fertilisers to pots
- improve the delivery of water to pots (less water falling on the ground)
- improve the retention of fertilisers in the growing media (less leaching)
- improve the retention of water in the growing media (less leaching)
- recycle waste water (less water disposed).

Improved delivery of fertilisers to pots

Whenever fertilisers and foliar sprays are applied to nursery plants some inevitably miss the target and end up being removed from the site in waste water. The most critical times for these losses are at potting up and when pots are topdressed, sprayed or drenched with fertiliser.

Growing media and surface applied fertilisers can also spill onto the ground when pots are watered, handled or knocked over. On the ground, coated fertilisers are easily damaged and this can cause nutrients to release quickly into waste water.

Management strategies

There are several strategies that you can implement in the nursery to improve fertiliser delivery to pots. These are as follows:

- Keep floor areas used for making or storing growing media and for potting up free of media and fertilisers. These areas may need to be bunded to contain runoff during periods of heavy rain or roofed in (see next section on improving delivery of water).
- If possible, mix or dribble fertiliser into the growing media at planting to

For more info

Trace elements in pot plants. What's the best way of supplying them? (journal), Handreck, K.A.(1995), *Australian Horticulture*, June pp 49–51

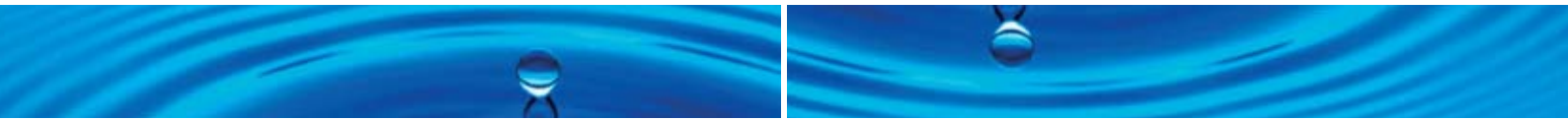

minimise subsequent spillage. Fertilisers should only be surface applied when it is necessary to top up the nutrient program.

- If you apply liquid fertilisers through overhead sprinklers make sure the waste water is collected for reuse or is treated before disposal. Liquid fertilisers can be applied less wastefully using drippers and bottom watering systems such as ebb and flow.
- It is preferable to mix micronutrients with the growing medium rather than doing it after planting as foliar or liquid fertiliser applications. Preplant micronutrients will usually last for 12 to 18 months. You may need to add boron more often.

For more info

Managing nursery runoff. Techniques to reduce nutrient leaching from pots (booklet), Cresswell, G.C. and Huett, D.O. (1996), NSW Agriculture, Orange

Managing water in plant nurseries (book), Rolfe, C.; Currey, A. and Atkinson, I. (1994), NSW Agriculture, Horticultural Research and Development Corporation and Nursery Industry Association of Australia

Water use and runoff comparisons of greenhouse irrigation systems (journal article), Neal, C.A. and Henley, R.W. (1992), Proceedings Florida State Horticultural Society, 105:191–194

Improved delivery of water to pots

Most nurseries in Australia use sprinkler irrigation systems.

Sprinkler irrigation without recycling is an inefficient way of watering containerised plants because water falls on the ground whether it is covered with pots or not and because high application volumes are often used to compensate for uneven watering patterns. Water use efficiencies can be as low as 10 %, where as much as 80 % of the water from a sprinkler may miss the target.

While it is often not practical to change from an already established sprinkler irrigation system, if you do have one it should be designed and maintained to maximise water application uniformity. The system should also be tested annually for uniformity.

Management strategies

Strategies to improve water delivery to pots with an overhead sprinkler system are as follows:

- Consolidate plants in irrigation bays to minimise watering open areas. Turn water off as areas become vacant.
- Reduce the spacing between pots and the area devoted to pathways so water wastage is minimised. Even when pot density is high more than half of the water from sprinklers generally falls outside of pots.
- Repot plants into larger containers as early as possible. This will reduce irrigation water losses between pots and increase the amount of stored water available to each plant allowing for longer periods between irrigations.

Bottom watering and drip irrigation offer water savings of 75 % or more over sprinklers and produce relatively little leachate so they should be used in preference to fixed sprinklers wherever possible.

Improved retention of fertiliser in potting media

Cation exchange capacity

Growing media generally have lower cation and anion exchange properties than fertile soil and consequently are less able to retain applied nutrients under leaching conditions.

In nurseries using an overhead irrigation system leaching losses are most severe in the first two weeks (7 to 14 waterings) after plants have been potted up. During this time most of the soluble fertiliser in the growing media is washed out and waste water nutrient concentrations are at a maximum.

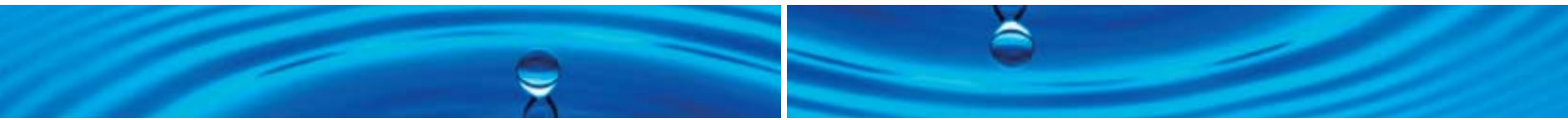

Although controlled release fertilisers are less susceptible to leaching than soluble fertilisers, they still produce an initial flush of nutrients which is often the result of early release from damaged prills.

Organic fertilisers are also vulnerable to severe leaching soon after application. Losses of nitrogen and potassium from pelleted poultry manure are highest in the first 4 weeks after addition.

Management strategies

When thinking about ways of improving retention of fertilisers consider the following:

- Adding growing media amendments such as zeolite or clay may increase cation exchange capacity and help retain soluble nutrient cations such as ammonium, potassium, calcium and magnesium.
- Composting or ageing organic materials used in growing media generally increases their cation exchange capacity.

Controlled release and soluble fertilisers

Dissolved nutrient salts and finely ground additives such as lime, dolomite and superphosphate are readily leached from most well drained potting media.

Research shows that leaching can remove from 53 to 93 % of applied soluble fertilisers and from 34 to 47 % of controlled release fertilisers during the life of a crop. Under Australian conditions, around 86 g of calcium and 75 g of sulphur is leached each month from every cubic metre of growing media .

Management strategies

When selecting or using controlled release and soluble fertilisers, consider the following:

- Controlled release fertilisers are less prone to leaching than soluble fertilisers such as potassium nitrate, calcium nitrate and urea because the prill is coated, to stop rapid dissolution of the nutrient salts inside.
- Use growing media as soon as possible after controlled release fertilisers have been added. Moisture and high temperatures associated with composting will trigger the release of nutrients and, without leaching, the salts may build up to toxic levels before the mix is used.
- Controlled release fertilisers may deteriorate if they are stored under conditions that are too hot or humid. Manufacturers will be able to advise on the best method of storage for their products. Don't use fertilisers with damaged coatings as they will release nutrients rapidly.
- The rate of nutrient release from controlled release fertilisers increases as soil temperature rises. Use fertilisers with thicker coatings for summer crops, e.g. a '9 month' formulation for a three-month growing period.
- Don't liquid feed plants immediately before a clear water irrigation or if rain is expected as most of the application could be flushed from the pot.
- Don't liquid feed when the crop is unlikely to use the fertiliser e.g. when temperatures are low or very high, or when light is low.

For more info

Managing nursery runoff – techniques to reduce nutrient leaching from pots (booklet), Cresswell, G.C. and Huett, D.O. (1996), NSW Agriculture, Orange

Improved retention of water in growing media

Irrigation scheduling

Nutrient leaching in sprinkler irrigated nurseries is often caused by overwatering. In these nurseries frequent, heavy irrigation is used to compensate for uneven watering patterns which result in dry pots, as well as to ensure that high basal fertiliser rates do not cause salinity.

For more info

Managing water in plant nurseries (book), Rolfe, C.; Currey, A. and Atkinson, I. (1994), NSW Agriculture, Horticultural Research and Development Corporation and Nursery Industry Association of Australia

Water use efficiency is at an optimum level when pots are only irrigated long enough to replace water lost since the last irrigation and a small amount for leaching. The amount of water applied should therefore closely match crop water use and evaporation losses. To achieve this, your irrigation schedule must be responsive to daily weather conditions.

The clock-based irrigation controllers used in most nurseries cannot satisfy this requirement. However, large water savings can still be made where these controllers are used if you can adjust the scheduling more often (see section on controllers in Chapter 1).

Management strategies

When scheduling irrigation in your nursery consider the following:

- Irrigate your plants when they need water rather than on a rigid cycle. You can anticipate water needs from weather data (evaporative pan), electronically (moisture and light sensors), by weighing pots (1 ml of water = 1 g), or simply from the appearance of plants.
- Change irrigation schedules with the season to account for natural patterns of rainfall and evaporation. Don't irrigate if enough rain has fallen (you can fit rain shut off devices to electronic controllers).
- Irrigate less when plant water use is low, such as when the weather is overcast or when plants are small.
- Group plants with similar daily water needs within irrigation bays to simplify scheduling. Plant species, size and canopy density are some of the factors that influence water needs.
- Maximise the uniformity of water application from sprinklers as this will reduce the volume of water needed to replace daily losses. Choose sprinkler nozzles that are appropriate for the spacings and line pressures at each site.

Growing media

Depending on their composition, growing media can have different abilities to retain surface applied water.

Under standard overhead irrigation (25 mm/hr), the most retentive mixes absorb as much as 80 per cent of the water as it drains through the mix, meaning that just 20 % is wasted. However, many mixes retain less than half and some as little as 20 % of the water applied.

Water retention is influenced by factors such as wettability, moisture content at irrigation, porosity and depth of the media, and the intensity of water application. On one hand, media that are still wet when they are irrigated have a reduced capacity to hold water. On the other hand, media that are allowed to dry out, especially those based on pine bark or with a high proportion of sphagnum peat, can be difficult to rewet.

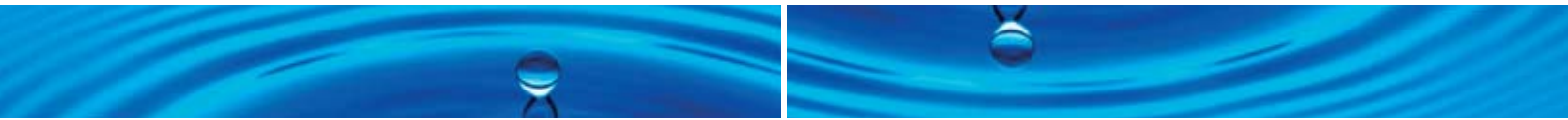

There is a limit to how quickly water can be absorbed by any mix and as the application intensity increases above this limit, water retention decreases greatly. As a general rule, few media are capable of absorbing water at a rate above 20 mm/hr.

Management strategies

When irrigating consider the following:

- Allowing media to become too dry between irrigations may make rewetting difficult. Even short periods of moisture stress can slow plant growth.
- Use a wetting agent (commercial product, coir etc) to improve water absorption in media that are difficult to rewet.
- Reduce the intensity of water application from sprinklers or drippers and shorten the length of irrigation to increase water absorption (see Chapter 1).
- With sprinkler or drip systems use two or three short waterings with a half to one hour interval between them in preference to a single lengthy irrigation (pulse watering). The time between each irrigation pulse allows water to be absorbed by the growing media and in this moistened condition some media become less water repellent. The optimum irrigation sequence will vary between nurseries and will be influenced by factors such as application intensity, media type, and plant and canopy size.
- Evaluate any new media under normal irrigation conditions to ensure that it has acceptable water retention properties (more than half of the applied water should be retained). This can be done by weighing pots before and after an irrigation to establish how much water the media has held.

Leaching fraction

The quantity of nutrients lost as a result of leaching is strongly related to the amount of water that drains from a pot at an irrigation. As the amount of leachate is reduced relative to the amount of water applied in an irrigation (called the leaching fraction or LF %), nutrient losses decrease and soil solution concentrations increase.

Some leaching (around 12 per cent LF) is needed to stop the crop being injured by salinity. However, any increase in the leaching fraction beyond this level will slow plant growth at low fertiliser rates. The leaching fraction in nurseries using fixed sprinklers commonly ranges from 50 to 80 %.

Management strategies

Some important management strategies to keep leaching to a minimum are as follows:

- Ensure the Sc of overhead systems is less than 1.5 to minimise variation in the leaching fraction over the bed or bench (see Chapter 1).
- Irrigate for long enough to give the smallest leaching fraction while still allowing for adequate rewetting of the growing media. A leaching fraction of 20 per cent or less is a useful target.
 - Reduce fertiliser rates rather than increase the leaching fraction if media salinity rises after irrigation scheduling has been optimised.
 - Consider a bottom watering system as an alternative to sprinklers or drippers. There is relatively little nutrient leaching when pots are watered from the bottom and this means that less fertiliser is needed.

For more info

Managing nursery runoff – techniques to reduce nutrient leaching from pots (booklet), Cresswell, G.C. and Huett, D.O. (1996), NSW Agriculture, Orange

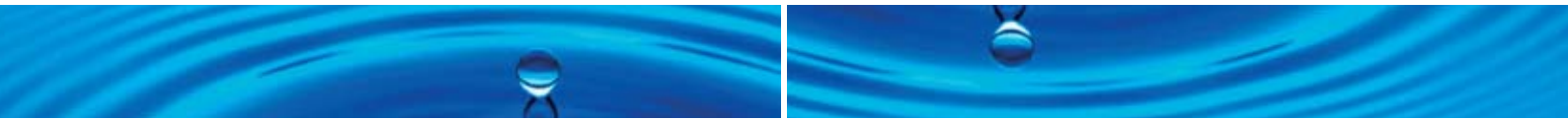

Fertiliser application

For greatest efficiency, supply nutrients at a rate that both reflects plant demand and satisfies losses due to factors such as nitrogen volatilisation or drawdown. When nutrient supply is too high, those nutrients dissolved in the soil solution are vulnerable to leaching. Nutrients are commonly oversupplied in the first few weeks after planting or repotting when plants are small and do not have a fully developed root system.

Management strategies

When applying fertiliser consider the following:

- Use the lowest rate of fertiliser that will give acceptable growth and quality. The optimum fertiliser rate will vary according to species, irrigation method, media type and growing conditions and so should be developed by each nursery. As an example, lower fertiliser rates are needed for outdoor stock in winter when plants are growing slowly.
- For advice on how to conduct research trials on commercial nurseries so you can determine the fertiliser regime that best suits your operation, speak with your State/Territory Nursery & Garden Association.
- Monitor the electrical conductivity (EC) of the growing media (see Appendix 3). If the EC increases when plants are receiving enough water a lower fertiliser rate may be appropriate.
- Evaluate your current nutrient program by comparing plant performance at lower and higher fertiliser rates (+/- 20 %) and by using plant tissue analysis to identify nutritional disorders.
- Minimise leaching losses by evening out nutrient supply to avoid periods when supply greatly exceeds demand. Applications can be split into two or more and spaced over the production period. Controlled release fertilisers with different release rates and formulations can be combined to better match nutrient supply to plant and climatic requirements.

For more info

Plant nutrient disorders
5. Ornamental plants and shrubs (book), Cresswell, G.C. and Weir, R.G. (1997), Butterworth-Heinemann, Melbourne (in press)

Recycling waste water

Many factors can affect the nutrient composition of nursery waste water. These factors include: plant species and stage of development, form of fertiliser used, the rate of and time since fertiliser application, rainfall, irrigation method, water scheduling, leaching fraction, and growing media composition.

Managing waste water

Large seasonal changes in the nutrient content of nursery water are normal. Collecting and storing waste water ensures that the most nutrient rich water does not leave the nursery as runoff or deep drainage without dilution. Additionally, nutrient concentrations in runoff can be greatly reduced by collecting water from roadways, carparks and buildings as the nutrient content of this water is normally lower than that collected from areas where containers are located (see Chapter 3 for more information).



Management strategies

To manage waste water in your nursery, consider the following:

- Collect and store waste water in a structure such as a dam or tank. (The larger the storage, the greater the potential for diluting this nutrient rich runoff.)
- Ensure the first 10 to 15 minutes of runoff water after an irrigation is collected or treated as this portion usually contains most of the debris, including growing media and fertiliser prills.
- Collect and treat all water from areas used for potting up, watering in after potting, or for storing media before it leaves the nursery.
- Monitor the quality of stored water and adjust the fertiliser program to make use of recycled nutrients. If the nutrient concentration increases or decreases over time you might need to change the fertilizer rate or formulation used.
- Seal growing areas and drains to minimise infiltration of contaminated waste water into soil.

Waste water may also need to be treated to reduce nutrient concentrations before being discharged where permitted.

One technique for reducing nutrient, chemical and sediment loads is to pass waste water through vegetated filter strips and constructed wetlands. Preliminary work has shown that nitrogen can be reduced tenfold in runoff water after passing through a constructed wetland. Constructed wetlands are also useful for containing runoff water after heavy rain. General design principles are based on holding or slowing the passage of water through the constructed wetland where a range of chemical, physical and biological processes can operate to store, transform or remove various pollutants. Generally, the longer the residence there the greater the treatment.

For more detail on filtering methods and reducing sediment loads, see Chapter 4.

For more info

Recycling water in the Australian nursery and flower industries: managing water quality and pathogen disinfestation (report), James, E.; Mebalds, M.; Beardsell, D.; van der Linden, A. and Tregaea, W. (1995), Final Report HRDC Project NY320, Horticultural Research and Development Corporation, Sydney

FURTHER READING

- Analysis of efficiency of overhead irrigation in container production** (journal), Beeson, K.C. and Knox, G.W. (1991), *Horticultural Science*, 26:848–850
- Artificial or constructed wetlands** (journal) Anon (1996), *Australian Nursery Magazine*, 20(4):14–16
- Constructed wetland manual** (book) (1997), NSW Department of Land and Water Conservation
- Light and fertiliser recommendations for production of acclimatized potted foliage plants** (journal), Conover, C.A. and Pool, R.T. (1990), *Nursery Digest*, 24(10):34–36, 58–59
- Loss of nutrients from containers with nursery plants** (report), Van der Boon, J. and Van Elk, B.C.M. (1986), Instituut voor BODEMVRUCHTBAARHEID, Report
- Managing nursery runoff – techniques to reduce nutrient leaching from pots** (booklet), Cresswell, G.C. and Huett, D.O. (1996), NSW Agriculture, Orange
- Managing water in plant nurseries** (book), Rolfe, C.; Yiasoumi, W. and Keskula, E. (Eds) (2002), NSW Agriculture, Orange
- Plant nutrient disorders 5. Ornamental plants and shrubs** (book), Cresswell, G.C. and Weir, R.G. (1997), Butterworth-Heinemann, Melbourne (in press)
- Recycling water in the Australian nursery and flower industries: managing water quality and pathogen disinfection** (report), James, E.; Mebalds, M.; Beardsell, D.; van der Linden, A. and Tregear, W. (1995), Final Report HRDC Project NY320, Horticultural Research and Development Corporation, Sydney
- Trace elements in pot plants. What's the best way of supplying them?** (journal), Handreck, K.A. (1995), *Australian Horticulture*, June pp 49–51
- The DOOR manual for plant nurseries** (book), Hunter, M.L. and Hayes, G.W. (1996), Queensland Department of Primary Industries, Brisbane
- The effects of temperature and time on the solubility of resin coated controlled release fertiliser under laboratory and field conditions** (journal), Lamont, G.P.; Worrall, R.J. and O'Connell, M.A. (1987), *Scientia Hort.*, 32:265–273
- Using pour-through extraction procedure in production regimes: optimum fertiliser rates and associated leachate electrical conductivity levels of twelve foliage plants** (journal), Conover, C.A.; Pool, R.T. and Steinkamp, K. (1992), *Foliage Digest*, (December): 3–7
- Water use and runoff comparisons of greenhouse irrigation systems** (journal), Neal, C.A. and Henley, R.W. (1992), *Proceedings Florida State Horticultural Society*, 105:191–194



6 ENVIRONMENTALLY RESPONSIBLE USE OF PLANT PROTECTION PRODUCTS IN QUALITY PLANT PRODUCTION

While the nursery industry alone is not a large enough user of plant protection products to affect whole catchments, it does have significant local impacts in terms of point source pollution. This is especially so where nurseries are located in an urban area or close to one.

In the last few years legislation has been enacted in most States/Territories to regulate some nursery practices to minimise their effects on the environment: This legislation, which many nurseries are already reacting to on their own initiative, can dictate how nurseries use chemicals and manage possibly contaminated waste water.

This Chapter presents some guidelines that detail how to manage your nursery whilst being mindful of the environment. For a more comprehensive overview, speak with your Industry Development Officer about the EcoHort guidelines. This program covers key areas including managing water, wastewater, noise, odour and air pollution. It also looks at enhancing energy efficiency and managing pesticides and chemicals above. This program builds on to NIASA as part of the Nursery Production Farm Management System.

Chemical application

Vapours, sprays and dust drifting in the air is a common problem that can be regulated relatively easily. This chapter outlines some options for using plant protection products in a way that ensures pest control as well as maintaining the safety of the environment and plant quality.

Waste water disposal

Another problem that is less well known (but probably as common) and more difficult to regulate, is the transport of materials such as pesticides, sanitisers and growth regulators in both runoff and drainage water.

In the largest segment of the nursery industry, namely containerised plant production, as well as in plant retailing, waste water problems are more specific. These problems relate to the fact that the permanently inundated soils and impermeable surfaces that are part of containerised plant production reduce or stop drainage through soil profiles. This increases runoff volumes and flow rates and does not allow the stripping of pesticides from waste water, which occurs naturally when it passes through soil.

Fortunately, a compensating factor is that the nursery industry uses much less pesticide, particularly on an active ingredient per site basis, than many other horticultural industries.

Note. Figures for maximum levels of a range of pesticide pollutants in water are available in the current Australian and New Zealand Environment and Conservation Council guidelines.

It is apparent from a number of Australian case studies that these figures are most likely to be those used to adjudicate on the acceptability of waste water as it either leaves the production site or enters common waters.

For more info

Australian water quality guidelines for fresh and marine waters, (booklet), (1992), Australian and New Zealand Environment and Conservation Council

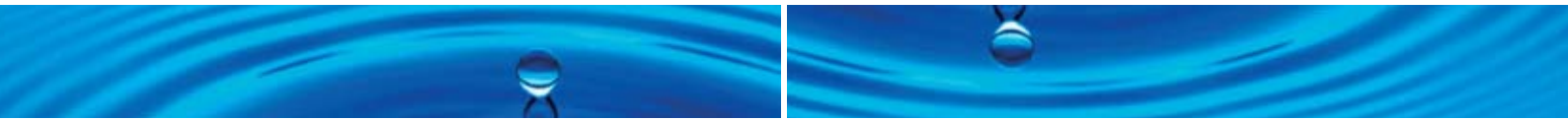

For more info

How to cope with urban sprawl (journal), Whitten, M. (1994), *Nursery Manager*, April 1994:42–49

Industry response to legislation and community pressure

It is interesting to examine a set of conclusions reached by the North American nursery industry, which has had to deal with government regulatory restrictions and very concerted community complaints for longer than the Australian industry. According to Whitten (1994) these are to:

- Operate only within current legislation.
- Have a properly documented environmental protection plan and code of practice for business. A contingency plan should be part of this.
- Maintain scrupulous records on pesticide use.
- Know and use independent experts, where available.

Nursery operators are constantly seeking information on techniques that will allow them to reduce pesticide use without compromising quality plant production. It is the aim of the chapter to provide a background to this, with a particular focus on maintaining a water quality suitable for reuse and discharge.

REDUCING LEVELS OF PLANT PROTECTION PRODUCTS IN WASTE WATER

Management practices you can adopt to, firstly, reduce contamination levels and, secondly, further reduce levels in recycled and discharged waste water before reuse or discharge are as follows.

Reducing pesticide use

A major way you can minimise the quantity of plant protection products finding their way into waste water is by reducing your overall total use of them. There are a number of strategies for doing this. Each of these strategies relies on either:

- limiting the number of applications
- or
- reducing the amount of active ingredient used for each application.

This will reduce the amount of chemical that can get into and be transported by water.

For more info

Best practice manual for pesticide application in the nursery and garden industry CD-ROM, Version 1 (2004), Horticulture Australia Limited

Ball field guide to diseases of greenhouse ornamentals (book), Daughtrey, M. and Chase, A.R. (1992), Ball Publishing, Geneva, Illinois

Improving diagnostic techniques on site and more routine use of diagnostic services

Knowing when and what disease or pest is affecting plants in the nursery is an essential first step to reducing chemical use. Unfortunately, the variety of species produced, the need for highly cosmetic plants to sell, the extreme artificiality of most of the plant environments in nurseries, and the large number of pests and diseases that can affect a plant species have all served to undermine the confidence of many nursery operators in diagnostic services.

As a result many operators rely heavily on the preventative, routine use of pesticides in combined applications. This means that some chemicals are used many more times in a year than is actually necessary, and some are used where they are never really needed at all.



While there will always be a need for some preventative, routine treatment (roses are a good example), there are many generic pests and diseases of nursery crops that you can learn to identify on site rather than having to rely on a consultant or diagnostic service. The more difficult or uncommon diagnoses are the only ones that should be referred to consultants or laboratories. You can learn these identification skills from:

- consultant training on site
- training institutions, particularly TAFE
- State nursery industry organised workshops and associations
- computer databases
- reference materials
- specialist nursery industry libraries, e.g. GrowSearch.

Other help is available through universities, State Government public and private laboratories, and a number of unaffiliated consultants. Some chemical distributors also offer diagnostic services to their customers.

Choosing the best chemicals and application strategies for your needs

If you don't identify a pest or disease correctly then you will probably apply the wrong chemical or chemicals. The result is crop damage by pests and diseases, wasteful use of chemicals, and an extra burden of pesticide in waste water.

It is important that when you do identify a pest, disease or weed correctly you also carefully choose the chemicals to use to control it. When choosing and using a chemical ask yourself the following:

- Do I really know if it works? Even chemicals registered for specific jobs may no longer work.
- Do I know if I need to use it on the whole nursery, just one crop, or just one part of the crop?
- How often does it really need to be used?
- Could I choose an equally good or better chemical that needs to be used less often?
- What other choices are available so that I can rotate chemicals and the quantity of the one active ingredient used on the nursery is reduced? Correctly alternating or more broadly rotating chemicals not only reduces the risk of resistance buildup (and the consequent need to use the chemical at higher doses or frequencies) but also reduces the concentrations of individual contaminants in waste water.
- Can I use the chemical more sparingly by treating motherstock or propagules rather than newly planted and spaced crops? This can also reduce the need to treat as often, and is relevant to a number of pests as well as many diseases.
- Can I use a chemical incorporated into the growing medium rather than an overall spray or drench? This can reduce runoff concentrations.
- Can I use the chemical more effectively by applying it at the most sensitive stage of the pest or disease lifecycle, thus reducing the number of applications?

For more info

Ornamental plants – pests, diseases and disorders (booklet), Bodman, K.; Carson, C.; Forsberg, L; Hughes, I.; Parker, R.; Ramsey, M. and Whitehouse, M. (1996), Information Series Q196001, Queensland Department of Primary Industries, Brisbane

Pest control in ornamental crops (booklet), Bodman, K.; Hargreaves, J. and Parker, R. (1993), Queensland Nursery Industry Association, Brisbane

The Nursery Industry Accreditation Scheme, Australia (booklet), Bodman, K. and Forsberg, L. (1994), Australian Horticultural Corporation, Sydney

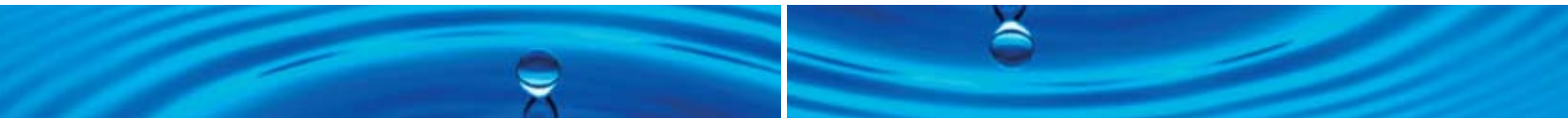

For more info

A review of pesticides in waste water and comments on implications to nursery production (booklet), Bodman, K. (1997), Queensland Department of Primary Industries, Brisbane

- Can I choose a chemical that controls more than one pest or disease, thus reducing the need to use a combination?
- How residual is the chemical in soil and water? It is important that you choose the least residual chemical or, if persistent pesticides are needed, that they only be broadly applied where the risk of runoff and drift is low.
- Given that the largest amount of pesticide is lost from the application site during and soon after the first heavy irrigation or rain, is it possible to time broadscale applications so that the pesticides have the longest possible time to be fixed to the crop and growing medium, and even degrade somewhat before leaching and heavy runoff?
- Knowing all of this is a tall order, particularly if you need to use a broad range of chemicals. However, your reseller and the label can answer at least some of these questions.

- Information on residual activity and environmental sensitivity of a number of useful nursery chemicals has been published and is generally available. However, remember that you need to refer your more specific enquiries to manufacturers' representatives, either directly or through their agencies.

Application equipment and chemical handling and storage

The most significant causes of chemical overuse and wastage are:

- inefficient equipment
- lack of operator training and inadequate supervision
- inadequate equipment and maintenance.

Fortunately these factors, which should be the first to be looked at when developing reduction strategies, are all generally easy to correct. Large savings are possible, for instance with the amount of active ingredient used.

There are excellent reference materials on this subject, and nationally accredited training courses on pesticide use are conducted regularly in all states.

The following strategies are recommended to reduce pesticide losses in drainage and waste water, as well as spray drift into water supplies:

- Keep pesticides under lock and key, well away from water supplies and direct drainage lines, and above all recorded flood levels. This should avoid the problem of highly concentrated point source pollution from concentrate spills, which has been a cause of concern in the past. For information on storing pesticides safely see Bartok 1996 and Ahrens et al 1994 as well as manufacturers' and government regulatory publications.
- Thoroughly rinse empty pesticide containers, and dispose of them in an approved way. You may collect the rinse water and use it during normal spraying operations.
- It is important to stop anti-backflow siphoning to protect water supplies used for filling spray vats. This will avoid acute water-source contamination, incidences of which have already occurred.
- Do not allow drainage and runoff from pesticide mixing and equipment washing

For more info

Courses aim for pesticide safety (journal), Tyldens, J. (1996), Australian Horticulture, August p 87

Guidelines to safe pesticide storage (journal), Bartok, J.W. (1996), Greenhouse Management and Production May pp 56–57

Managing the pesticide risk (journal), Smith, E. (1996), Australian Horticulture, August pp 90–91

Pesticide application manual (book), Banks, A.; Broadley, R.; Collinge, M. and Middleton, K. (1994), 2nd Edition, Information Series Q1 89003, Queensland Department of Primary Industries, Brisbane



facilities to enter water supplies. This may involve using bunded mixing areas on concrete, complete with sump traps, if other sites on the nursery are unacceptable.

- If possible, allow for buffer zones between application sites and receiving waters in the design of your nursery.
- If you do not use all of the diluted pesticide in the spray vat in a normal spraying operation and don't want to keep it to use in the next application dispose of it by spraying it onto vegetated, porous, non water-repellent soils well away from watercourses and drainage pathways. It is best to do this when low rainfall is predicted. Removal by a toxic waste disposal company is another, expensive, alternative. You must not, under any circumstances, allow it to enter water.
- Have an emergency strategy to deal with an accidental spill of either concentrate or spray dilutant anywhere on the nursery site. This is necessary for both workplace and environmental safety. If only a small area of soil is involved in a spill it can be excavated and spread over, or preferably cultivated into, much larger volumes of soil in non-sensitive areas. The highest risk spills occur in drainage pathways. Where these spills have entered irrigation supplies they have caused crop damage, either quickly or months after the event.

For more information on dealing with spills see Ahrens et al, 1994. Manufacturers also have more specific safety data and this is available from all resellers, generally when you buy the pesticide.

- Use diversion drains and, where possible, grassed banks to protect dams from contaminated waste water.

Many of these strategies are used by nursery operators already, particularly where they also affect personnel safety. Some nurseries with low volume storage requirements and use have found that the cost of storing pesticides and having mixing facilities that adhere to the regulations have been a deterrent to having them installed. However, it is worth noting that one government regulatory body has commented that the cost of preventing contamination is a fraction of that of cleaning it up.

Using alternatives to pesticides

The relatively recent development of very effective pesticides, miticides, fungicides, herbicides and nematicides has allowed agriculture to stray from traditional practices of good hygiene and environmental control. This has a strong parallel with preventative human and veterinary health practices after the development of antibiotics.

However, we are now discovering the value (and, in some cases, necessity) of putting more effort into these practices.

The first swing away from pesticides occurred with the development of broadscale pesticide resistance and more recently this has been supported by the need for more environmentally acceptable practices, both for the workplace and the general community.

The first thing that comes to mind when pesticide alternatives are mentioned is integrated mite and insect control. Although these techniques are what we read about in the literature most, they are a very small part of total pest and disease integrated management.

Many traditional practices that have been abandoned can be considered as aspects of pest, disease and

For more info

Recycling and resource conservation – a reference guide for nursery and landscape Industries, (book), Ahrens, J.F.; Bonnet, R.E.; Castagnero, C.; Cornell, C.F.; Glenister, C.S.; Gouin, F.R.; Hock, W.K.; Kabashima, J.; Michalsen, L.H.; Niermiera, A.X.; Nuss, J.R., Ross, D.S., Rynk, R.F., Skimina, C. and C. Champney Urbano (1994), Pennsylvania Nurserymen's Association Inc., Harrisberg, Pennsylvania

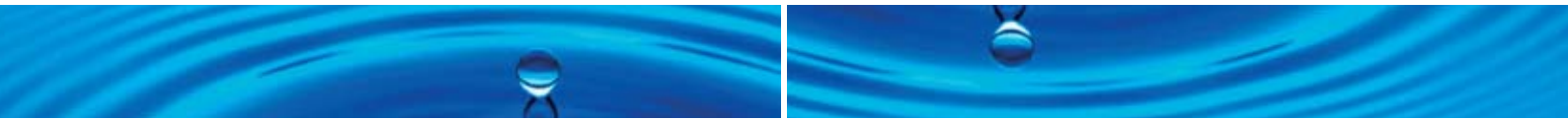

weed integrated management and deserve to be revisited and reintegrated in nursery crop protection programs. In particular, we need to reinvest in techniques of pest and pathogen exclusion as well as consider wider use of biological agents.

Pathogen exclusion techniques are not always understood in nurseries today. These techniques can be as simple as inspecting, quarantining, and rejecting or treating new plant intakes to stop 'new' pests, diseases and weeds being introduced into the nursery. They can also be comprehensive, expensive integrated procedures such as water treatment, upgrading standing surfaces and drainage, treating media (not always necessary), and installing insect proof houses. Of course, none of these investments will be fully realised without effective staff training.

As well as exclusion, which is a hygiene measure, modifying plant environments can result in use of less pesticides, particularly fungicides. Usually these techniques involve things such as decreasing humidities through modifying irrigation, improving air drainage and wider crop spacing or modified growing structures.

What is stopping the broader adoption of techniques to reduce dependence on pesticides are obviously the capital costs involved and, in many cases, the need for information. While the start up costs of these methods are high there are good examples of nursery operators making large savings through increased productivity, quality and consumer satisfaction.

For more info

Recycling and resource conservation – a reference guide for nursery and landscape industries, (book), Ahrens, J.F.; Bonnet, R.E.; Castagnero, C.; Cornell, C.F.; Glenister, C.S.; Gouin, F.R.; Hock, W.K.; Kabashima, J.; Michalsen, I.H.; Niermiera, A.X.; Nuss, J.R., Ross, D.S.; Rynk, R.F.; Skimina, C. and C. Champney Urbano (1994), Pennsylvania Nurserymen's Association Inc., Harrisberg, Pennsylvania

Using biological agents is more expensive in some cases than using chemicals (but only where effective chemicals are available), however, history has shown that it is unwise to assume that new pesticide resistance is not just around the corner.

Another limit to the adoption or readoption of the above techniques is the lack of established support industries, including consultants, to the nursery business.

Dealing with pesticide spills

Handling concentrates, unsprayed solutions and suspensions has been identified as a critical step in protecting water from pesticide contamination. Spills during these operations are regarded as being major human and environmental health problems. As such, it is vital that businesses have a written protocol, available to all staff, which deals with spills as well as other chemical emergencies.

Herbicide spills which have ultimately entered water storages have caused major crop damage. As well, the highest recorded concentrations of other types of pesticide pollutants in dams have resulted from spills. Information on reducing the risk of and cleaning up spills can be found in Ahrens et al .1994, Appendix D. More specific information is also available from chemical manufacturers and is included in courses dealing with chemical application e.g. the Farm Chemical Users Course or Chem Cert.

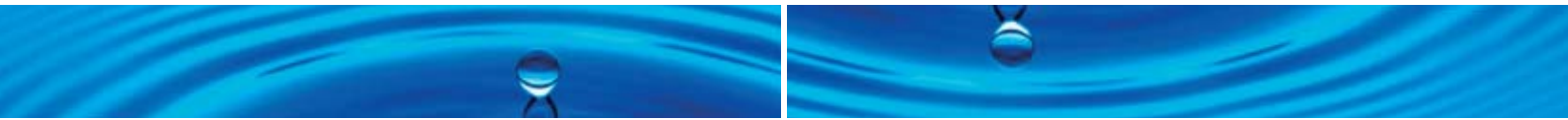

Reducing pesticide concentrations In water storages and waste water

Before waste water enters water storages and is discharged

Depending on the chemical, pesticides may travel either in a dissolved state or attached to particles moved by water, e.g. soil or growing media.

Particulate matter is trapped very easily by gravel beds, and organic matter such as compost fines in the gravel possibly can act as a site of pesticide degradation. The flow of water draining from gravel beds is slowed and subsequent runoff is substantially free from visible debris. For more information on this see Chapter 4 of this publication.

Pesticide residues not attached to eroding layers are greatly reduced if they enter soil profiles. The rate of their degradation depends on a range of soil conditions such as pH, drainage and organic content. Where there is suitable land on nurseries, you might give some thought to using it as a site for stripping pesticides (and nutrients) from waste water.

Particle gravitational traps and screens may be especially necessary for nurseries sited on ungravelled surfaces. For more details see Chapter 4 of this publication.

Land suitable for leach fields is not often available for nursery operations.

Reducing volumes of waste water

This general topic is covered in other chapters of this publication. However, as pesticides are usually degradable, the longer a chemical has before being washed or leached from the site where it is applied the lower the concentration entering waste water. Also, the disadvantage of reducing runoff volumes of water after pesticide applications is that concentrations of the chemical may actually increase. A compensation is that reduced runoff volumes make it more feasible to store contaminated water on site and, if necessary and safe to the crops, use it there.

Impounding runoff

Pesticides can be degraded in on site water storages and, if necessary, it can then be diluted enough before they are reused or discharged so they aren't a threat to the environment or nursery stock.

Effective impoundment will obviously depend on reducing volumes of runoff to meet available storage capacity. Major limitations are lack of space on site and the cost of impoundment where water storages do not already exist (this may include lost production areas).

Recycling and reuse

Captured runoff water can have value if you are able to use it again on site. Some nurseries use it to irrigate inground crops on their own or even neighbouring properties.

Recycling implies that the same water is used again and again. If this is the case on your nursery you may have to deal with a number of significant problems. These are discussed more comprehensively in other chapters in this publication, however, there are some specifics about pesticide pollutants that you need to consider if you adopt this strategy.

For more info

A review of pesticides in waste water and comments on implications to nursery production (booklet), Bodman, K. (1997), Queensland Department of Primary Industries, Brisbane

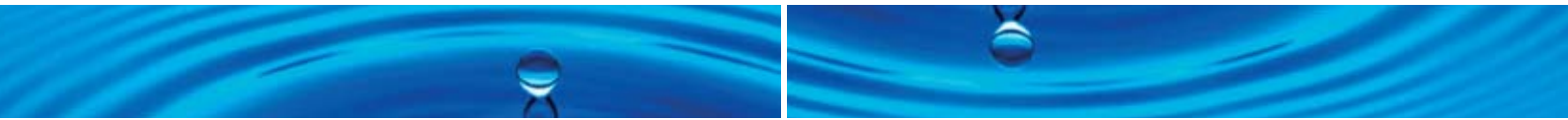

For more info

A review of pesticides in waste water and comments on implications to nursery production

(booklet), Bodman, K. (1997), Queensland Department of Primary Industries, Brisbane

Pesticide waste water disposal: biological methods

(book), Craigmill, A.I. and Winterlin, W.I. (1988), in Bridges, J.S. and Dempsey, C.R. Pesticide Waste Disposal Technology, Moyes Data Corporation, Park Ridge, New Jersey

With constant recycling (or even on first reuse) concentrations of phytotoxic pollutants can build up. While many nursery operators have recycled water successfully, others have experienced crop or quality losses, particularly when total water storage levels have fallen or the ratios of used to unused mixtures have increased. The resultant effects can range from an easy to a difficult, lengthy diagnosis of an acute or chronic decline in crop performance.

Compared with most nutrient and other salt levels, pesticide pollutants are very expensive to monitor. Breakdown products may be as phytotoxic as their parent compounds and also may need assaying. Assays may indicate the presence and concentrations of pollutants, but little may be known about their relevance to crop damage when it occurs.

Treating waste water on site

Diluting stored waste water has already been mentioned, however, there are refinements to this where storages are connected in series. In this situation retention, degradation and dilution as water passes from one storage to another can be controlled.

A number of on site treatment possibilities have been researched, including activated carbon filters, ozonation, reverse osmosis and aeration. Slowly filtering waste water may be moderately effective in biodegrading pesticides. Coarse gravel has been used to do this, and compost filters can also degrade some insecticides and miticides.

These methods can be used if you know what the contaminants are. Some are untried in practice (they have been used in research projects only) and others are expensive to install and operate.

INDIVIDUAL PROPERTY WASTE WATER CODES OF PRACTICE

Businesses need long term plans and goals. These plans need to incorporate financial provisions and strategies for risk management. Successfully reducing contaminants in waste water should be part of these risk management and financial plans.

To determine how a business will reach its goals it is first necessary to know where it currently is. In terms of pesticide use and contamination reduction, the long term plan begins with accurately assessing:

- quantities of pesticide currently being used
- the cost of their use
- losses solely due to failures in crop protection.

The aim should be to reduce all three when estimated annually.

To assess risk due to waste water contamination you should have analyses of waste water entering storage and being discharged from the nursery site. View discharge in the context of where the nursery is located in terms of environmentally sensitive situations, e.g. near edible crops, schools, watercourses etc.

As the goal is to reduce contamination levels these figures are your starting point. The result should be a permanent document with recorded achievements able to meet the scrutiny of external reviewers, if that is necessary. Enough information can be included to evaluate future investment needs and meet your future or current quality assurance documentation standards.



The pesticide use records most commonly kept at present under legal obligation will provide some useful information, however, if you do not already include it, expand these to take account of quantities of concentrate and dilutant use per unit area, the reasons for applying the chemical(s), and if it (they) did or did not work as well as expected.

FURTHER READING

Australian water quality guidelines for fresh and marine waters (booklet), (1992), Australian and New Zealand Environment and Conservation Council.

Ball field guide to diseases of greenhouse ornamentals (book), Daughtrey, M. and Chase, A.R. (1992), Ball Publishing, Geneva, Illinois

Courses aim for pesticide safety (journal), Tyldens, J. (1996), *Australian Horticulture*, August p 87

Guidelines to safe pesticide storage (journal), Bartok, J.W. (1996), *Greenhouse Management and Production*, May pp 56–57

How to cope with urban sprawl (journal), Whitten, M. (1994), *Nursery Manager*, April pp 42–49

Managing the pesticide risk (journal), Smith, E. (1996), *Australian Horticulture*, August pp 90–91

The Nursery Industry Accreditation Scheme, Australia (booklet), Bodman, K. and Forsberg, L. (1994), Australian Horticultural Corporation, Sydney

Ornamental plants – pests, diseases and disorders (booklet), Bodman, K.; Carson, C.; Forsberg, L.; Hughes, I.; Parker, R.; Ramsey, M. and Whitehouse, M. (1996), Information Series Q1 96001, Queensland Department of Primary Industries, Brisbane

Pesticide application manual (book), Banks, A.; Broadley, R.; Collinge, M. and Middleton, K. (1994), 2nd Edition, Information Series Q1 89003, Queensland Department of Primary Industries, Brisbane

Pest control in ornamental crops (booklet), Bodman, K.; Hargreaves, J. and Parker, R. (1993), Queensland Nursery Industry Association, Brisbane

Pesticide wastewater disposal: biological methods (book), Craigmill, A.L. and Winterlin, W.L. (1988), in Bridges, J.S. and Dempsey, C.R., *Pesticide Waste Disposal Technology*, Moyes Data Corporation, Park Ridge, New Jersey

Recycling and resource conservation – a reference guide for nursery and landscape industries (book), Ahrens, J.F.; Bonnet, R.E.; Castagnero, C.; Cornell, C.F.; Glenister, C.S.; Gouin, F.R.; Hock, W.K.; Kabashima, J.; Michalsen, L.H.; Niermiera, A.X.; Nuss, J.R.; Ross, D.S.; Rynk, R.F.; Skimina, C. and C. Champney Urbano (1994), Pennsylvania Nurserymen's Association Inc., Harrisberg, Pennsylvania

A review of pesticides in waste water and comments on implications to nursery production (booklet), Bodman, K. (1997), Queensland Department of Primary Industries, Brisbane

Best Practice Manual for Pesticide Application in the Nursery and Garden Industry CD-ROM, Version 1 (2004), Horticulture Australia Limited



APPENDIX 1

CALCULATING COEFFICIENT OF UNIFORMITY, MEAN APPLICATION RATE AND SCHEDULING COEFFICIENT

Overview

When selecting a system, you have three objectives:

1. Apply water evenly (Coefficient of Uniformity; C_u)
2. Apply water at the right rate (Mean Application Rate; MAR)
3. Apply water to the whole area, minimising dry spots (Scheduling Coefficient; S_c)

Coefficient of Uniformity (C_u)

The Coefficient of Uniformity measures how evenly water application is distributed and takes both wet and dry areas into account and relates their application to the mean application rate. C_u is calculated as a percentage, with 100 % being the absolute ideal. A minimum value for fixed overhead systems is 85% and the closer you get to 100 % the better.

Mean Application Rate (MAR)

To take full advantage of the water holding capacity of your growing media, the Mean Application Rate (MAR) should be less than the absorption rate of the growing media. The absorption rate will be governed by the composition of your growing media. Composted pine bark mixes commonly have an absorption rate of 10 – 12 mm/hour while medias with a significant proportion of coir can raise this rate to be as high as 15 – 20 mm/hour. Generally you should be looking at selecting an application rate of between 5 and 12 mm/hour. Lighter application rates should be considered for small plug containers and seedlings.

Scheduling Coefficient (S_c)

Scheduling Coefficient is a measure of the extra time required to irrigate the area to ensure that the driest section (2 %) receives the required water application. It is expressed as a number greater than 1, with 1 being the ideal S_c .

For example, if we need to apply 5 mm of irrigation to a block with a Scheduling Coefficient of 2, the driest areas only receive 2.5 mm for a 5 mm application. Otherwise, to ensure the dry areas receive sufficient water, you would need to overwater the rest by applying 10 mm of water.

The Scheduling Coefficient has a significant impact on water consumption, fertiliser leaching, potential growth rates and consistency of product. A good S_c is 1.2 and the upper limit for most situations is 1.5.

$$\text{Coefficient of Uniformity} = \left[1 - \frac{(\text{average deviation from average catch})}{\text{average catch}} \right] \times 100$$

$$\text{Mean Application Rate} = \frac{\text{total volume per hour of catch containers}}{\text{No. of catch containers}}$$

$$\text{Scheduling Coefficient} = \frac{\text{average catch rate}}{\text{lowest catch rate}}$$

To achieve a Scheduling Coefficient of less than 1.5 it is necessary to ensure that all containers receive water from four full circle sprinklers.

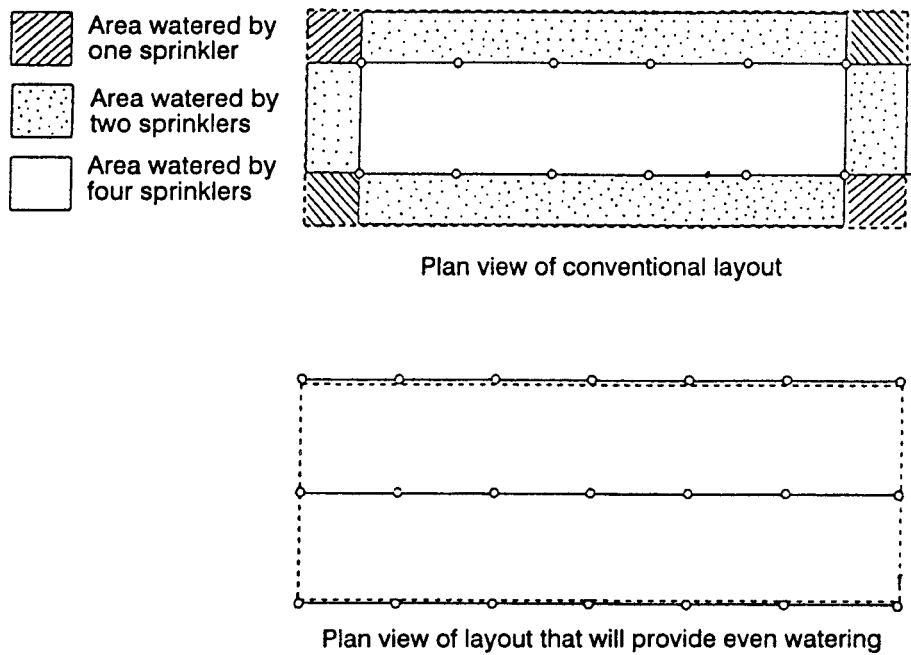

Fig. 17 – Low Scheduling Coefficients can be achieved if each container receives water from four sprinklers

Although the proposed layout has more sprinklers than the conventional layout, the low Scheduling Coefficient means the proposed layout will use less water, apply water more evenly and reduce excessive fertiliser leaching.

Example

Each block shown is fitted with sprinklers at 4 metre centres, applying 8 mm/hour with a Cu of 85 % discharging 130 litres/hour. The conventional layout has 12 sprinklers and a Sc of 2.2 with the driest areas at the comers. The proposed layout has 21 sprinklers and a Sc of 1.2.

Comparing the two systems

	Conventional layout	Proposed new layout
Area watered	$6 \times 22 = 132 \text{ m}^2$	$8 \times 24 = 192 \text{ m}^2$
Time to apply a 6 mm application	$\frac{6 \times 60 \times 2.2}{8}$ = 99 minutes	$\frac{6 \times 60 \times 1.2}{8}$ = 54 minutes
Volume of water applied	$\frac{128 \times 12 \times 99}{60}$ = 2,534 litres	$\frac{128 \times 21 \times 54}{60}$ = 2,419 litres
Translated to 200 such applications over a one hectare nursery, the volumes are:		
	$19.2 \times 200 \times 10,000$ = 38.4 megalitres	$12.6 \times 21 \times 54$ = 25.2 megalitres



APPENDIX 2

INPUT DATA FOR NURSERY PRODUCTION ECONOMIC MODEL

This model was developed to compare water savings; dollar returns and increase in business potential for nurseries that wished to retrofit the irrigation and drainage systems on their nurseries via a cost/benefit analysis. The model has been designed in Microsoft Excel.

This model takes the base data prior to retrofitting and the changed case after retrofitting and uses a standard discounted cash flow (DCF) investment analysis framework.

The DCF estimates the net Present value (NPV) or lump sum present value equivalent of the incremental cash flow stream over the term of the investment. It arises directly as a result of estimating the difference in the annual cash flow pattern for the business, with and without the proposed changes. Thus the NPV determines the present day value of any investment over the period of time at the quoted discounted rate.

The NPV result determines whether a proposed investment is likely to be viable or not. An investment is said to viable if the NPV is positive at the quoted discount rate of 7 % over the investment time of 10 years for the generic economic model.

This generic economic decision model utilises a series of economic spreadsheets for the nursery industry to assess proposed changes to a business in regard to water saving technologies to allow growers to plan and implement water use efficiencies based on return on investment.

It will also provide estimates on other operational cost savings such as reduced electricity cost, plant throw outs, fertiliser and chemical usage.

For industry, the key to achieving a positive return on investment for upgrading irrigation systems is to first assess the existing irrigation system performance and the current costs of operating. Once data is established you can then compare the performance data to industry Best Management Practices in irrigation performance and determine the likely water use savings you would expect to achieve. The cost of any alternative water source and outlay to achieve the retrofit can then be assessed using the generic economic model to measure the net worth of the outlay.

The spreadsheet inputs are divided into the following sections

- Income (before and after retrofit)
- Capital costs
- Fixed costs (showing calculated cost savings for new system)
- Variable costs (showing calculations of new system savings)

The model then does a discounted cash flow analysis over ten years using

- Current system scenario
- New system scenario
- Benefits of new system.

It then prepares a cash flow summary which shows the pay back period for the investment, the benefit cost ratio which describes the return for every dollar invested.

Finally the model prepares an overall summary detailing the water savings in megalitres and the change in business profit.

Within the model, all yellow cells are data entry and the red cells are calculated by the model.

Typical inputs include:

Income

Sales
Other
Total sales
Other sources
Intellectual property
Agency income
Consulting
Interest
Diesel rebate
Misc income
Freight collected

Capital costs

Buildings and roads
Office equipment
Vehicles
Nursery infrastructure and equipment
Irrigation (both old and new)

Fixed costs

Accountant
Advertising
Bank charges
Book keeping
Broadband
Cleaning
Electricity
First aid
Hire plant & equipment
Licenses and fees
Motor tolls
Motor vehicle expenses
Pest control
Rates
Repairs and maintenance
Security
Technical books & journals
Telephone
Tool replacement
Town water charges
Wages
Waste disposal
Water testing
Work cover
Workplace health & safety

Variable costs

Bags
Blades
Cartons
Chemicals
Commissions
Containers
Freight
Fungicide
Herbicide
Insecticide
Labels
Levies
Payroll tax
Plants
Plastic trays
Growing media
Pots
Seed
Stakes
Tape
Ties
Wax trays
Weed mat

APPENDIX 3

CONSIDERATIONS WHEN DEVELOPING A DRAINAGE, SEDIMENT AND LITTER CONTROL PLAN

When designing for or operating at a particular site, consider the: physical limitations that affect the site and how to address them. This can reduce: both the: construction costs and the level of future maintenance. Integrating drainage, erosion and sediment control at the planning stage is more cost effective than establishing controls and undertaking remedial work once the nursery is completed.

Physical limitations can be divided into two categories, topographic limitations, which are summarised in Table 11 and soil limitations, summarised in Table 12. Terrain limitations are summarised in Table 13.

Table 11. Topographic limitations

Topographic limitation	Considerations
Slope	Gentle slopes generally impose little limitation to development, while steep slopes present problems because of increased runoff velocity and a greater requirement for cut and fill earthworks. The length of slope influences the volume and velocity runoff, while the shape of a slope can further influence the erosion potential through variations in vegetation cover and micro-climates.
Terrain	The type of terrain can help identify unstable areas. Commonly occurring terrain types and considerations are in Table 13.
Flooding	If the drainage system cannot handle the volume of runoff then low lying areas will be flooded. Floodway obstructions such as buildings also increase flow velocity and turbulence.
Shallow soils and rock	Rock surfaces and shallow soils reduce infiltration and produce high runoff rates.
Sand dunes	In their natural state they are usually stabilised with vegetation and development can destroy this protective vegetation. The most sensible approach is to leave them undisturbed.
Wave action	Land adjacent to water bodies, like lakes, can be affected by wind generated waves.
Wetlands	Wetlands provide natural detention storage for floodwater and filtration for sediment. Disturbing them will result in loss of these benefits.
Site drainage	Poor drainage may lead to increased surface runoff, soil erosion, slope instability and flooding.
Mass movement	The movement of soil material down slopes is commonly triggered in infiltration, which reduces the soils shear strength.
Streambank erosion	The removal of soil materials from streambanks by the direct action of stream flow.

Table 12. Soil limitations

Soil limitation	Considerations
Slope pH	Soils with extreme pH levels experience increased erosion and sediment problems, and are more difficult to revegetate.
Acid surface soils	These soils are poorly drained, restrict the growth of stabilising vegetation and area a major problem if exposed to the air. The most sensible approach is to leave them undisturbed.
Water repellent soils	Water repellent soils do not readily absorb water when they are dry and therefore have high rates of runoff. They are difficult to revegetate and are very prone to erosion.
Expansive and reactive soils	these soils shrink and swell markedly with changes in moisture content. Soil movement can destroy or damage buildings, walls, dams, roads and paths leaving the soil exposed to erosive sources.
Sodic soils	Sodic soils are extremely erodible. Plant germination and growth is usually poor. Try and avoid nursery development on these soils.
Non-cohesive soils	Soils, such as sands, are extremely erodible. Steep cuttings or batters are not suited with these soils and retaining structures are usually required.
Low fertility	Low fertility soils are more likely to erode than more fertile soils as they are less likely to be stabilised with vegetation.
Saline soils	Saline soils are often poorly drained and sodic. They are extremely erodible. Soil salinity problems may be triggered by development activities which raise saline water tables.
Toxic soils	Toxic soils predisposed to erosion are difficult to vegetate. Toxicity may be associated with extremes of pH, chemical pollutants, or soil pathogens.
Unconsolidated soils	Uncompacted fill and disturbed soils are extremely erodible. They are also prone to differential settlement, which may damage greenhouses and paths. For these reasons you should minimise cut and fill and ensure fill is compacted.
Hardsetting and surface sealing soils	These soils become hard and compact when dry, making water infiltration difficult. The result is high runoff. Seedling germination is difficult and mulches or cover crops are recommended to help retain soil water and protect bare soil.

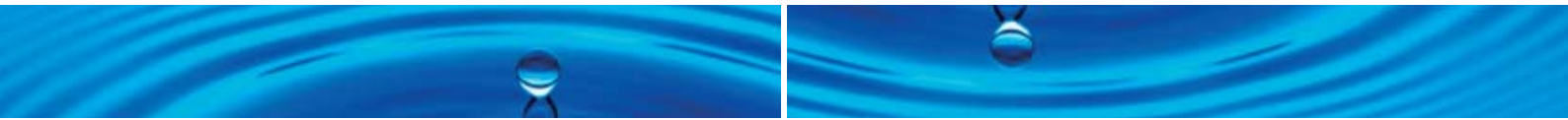

Table 13. Terrain types and considerations

Terrain type	Considerations for sediment and litter generation
Ridge crest	Shallow soil; rock outcrops; poor drainage; high runoff
Sideslope	Mass movement
Footslope	Flooding from overland flow; seasonal waterlogging
Floodplain	Flooding; waterlogging
Drainage line	Flooding; waterlogging; streambank erosion; saline soils
Dune	Wave erosion; high permeability
Escarpment	Shallow soils; rock outcrops; mass movement; high runoff



APPENDIX 4

POUR-THROUGH TECHNIQUE

This test is normally done 1 to 2 hours after irrigation, when the moisture content of the mix is close to container capacity

The procedure is that water is slowly added to the surface of a pot until 50 to 100 ml of leachate has been displaced from the mix. As a general rule, no more than 100 ml of leachate should be obtained for each litre of mix.

This procedure should be repeated on five to ten randomly selected pots to cover possible variation in a growing area.

The electrical conductivity of the leachate is a guide to the salt/nutrient content of the soil solution. Values above 2 dS/m are considered high for some species. For further information on interpreting results, see Conover, Pool and Steinkamp's article in *Foliage Digest*.

REFERENCE

Using the pour-through extraction procedure in production regimes: optimum fertiliser rates and associated leachate electrical conductivity levels of twelve foliage plants. Conover, C.A.; Pool, R.T. and Steinkamp, K. (1992), *Foliage Digest* (December): 3–7

